

Table of contents:

Manual changelog

- Revision 8 (04/03/2026)
- Revision 7 (19/11/2025)
- Revision 6 (18/06/2025)
- Revision 5 (15/04/2025)
- Revision 4 (15/04/2025)
- Revision 3 (03/04/2025)
- Revision 2 (25/03/2025)
- Revision 1 (17/03/2025)

Introduction

- History
- Developer notes

General description

- Specifications
- Detailed views
 - Main panel
 - Lower panel
 - Overhead instruments
 - Right console
 - Left console
 - Upper left console

Engines and auxiliary power

- Engines
 - Throttle
 - Exterior components
 - Intake flaps
 - Variable position nozzle
- Auxiliary power
- Engines operation
 - Startup
 - Monitoring
 - Tachometers
 - EGT Indicators
 - Nozzle position indicator
 - Fuel Flow indicator

- Fire

Fuel system

- Description
- External fuel
- Fuel transfer
- Fuel dump

Electrical system

- Description
 - A/C power generation
 - D/C power generation
 - Ground power
- Lights
 - Exterior
 - Interior
- Alarms
 - Alarms panel
 - Other alarms

Hydraulics

- Description
 - Hydraulic power transfer
 - Electrical pump
- Landing gear
 - Steering
- Flaps and slats
 - Slats operation
- Airbrakes
- Refueling probe
- Brakes

Flight controls

- Servo control system
- Yoke
- Lateral system
 - Force feedback (AJAX)
 - Spoilers
 - Differential deflection mechanism
 - Rudder
- Longitudinal system

- Pitch damping
- Trim

Avionics

- COM/NAV
- TACAN
- Navigation indicator
 - Additional vector
- Sphere indicator
- Heading control panel
- IFF/Transponder
- HUD
 - Approach mode
 - Air-air mode
 - Air-ground mode
- GPS
- Autopilot
- Radio altimeter
- Clock

Electronic flight bag

- Aircraft
- Display options
- Fuel
- Weapons
- Map
- Autopilot
- Info

Procedures

- Reference speeds
- Checklists

Performance

- Takeoff
- Climb
- Cruise
- Descent
- Landing

Controls assignments

- Custom events

MSFS 2024 specific

- Preflight actions
- Weapons system
 - Enable weapons
 - Weapons panel
 - Air/ground weapons
 - Air/air weapons
 - Guns
 - Inert stores jettison
- Landing drag chute

Manual changelog

Revision 8 (04/03/2026)

- New documentation on Docusaurus.

Revision 7 (19/11/2025)

- Added new section for landing drag chute (**Landing drag chute**).
- Described new quick preflight button on EFB (**Preflight actions**).
- Added notes about GR over-wing weapons (**Air/air weapons**).

Revision 6 (18/06/2025)

- Following update, added binding name to toggle nose wheel steering (**Steering**).
- Added more details about fuel totalizer (**Description**).
- Added APU fuel flow indication (**Fuel Flow indicator**).
- Described navigation indicator test procedure (**Navigation indicator**).
- Created new section to explain the clock (**Clock**).

Revision 5 (15/04/2025)

- Added explanations about stores jettison (**Inert stores jettison**).

Revision 4 (15/04/2025)

- Following release of the native FS 2024 product, added a new section with specificities (**MSFS 2024 specific**).

Revision 3 (03/04/2025)

- Added note about external stores drag (**Weapons**).
- Following update 1.1.0, added "oxygen refill" button description (**Aircraft**).
- Following update 1.1.0, described NAV panel testing (**COM/NAV**).

Revision 2 (25/03/2025)

- Added more details about fuel cutoff with throttle (**Throttle**).
- Added explanations on how to operate 4-way switches (**Interior**).
- Added explanations about moving and hiding the tablet (**Electronic flight bag**).

Revision 1 (17/03/2025)

- First version.

Introduction

History

The SEPECAT Jaguar is a product of Anglo-French collaboration, developed to meet both nations' requirements for a versatile military aircraft. In the early 1960s, the United Kingdom sought an advanced supersonic jet trainer to replace the Folland Gnat T.1 and Hawker Hunter T.7, while France aimed to acquire a cost-effective subsonic dual-role trainer and light attack aircraft to succeed the Fouga Magister, Lockheed T-33, and Dassault Mystère IV. This convergence of needs led to the signing of a memorandum of understanding in May 1965, initiating the joint development of the aircraft.

To manage this binational project, the Société Européenne de Production de l'Avion d'École de Combat et d'Appui Tactique (SEPECAT) was established in 1966 as a joint venture between the British Aircraft Corporation (BAC) and the French company Breguet. The collaboration combined British and French aerospace expertise, resulting in an aircraft that evolved from its initial training role into a capable supersonic ground-attack and reconnaissance platform.

The Jaguar's maiden flight occurred on 8 September 1968, marking the beginning of its operational journey. The aircraft entered service with the French Air Force in 1973 and the Royal Air Force (RAF) in 1974. In the RAF, the Jaguar GR1 became a cornerstone of tactical support and ground-attack operations, equipping eight front-line squadrons. It played a significant role in RAF Germany's Cold War air capabilities until it was gradually replaced by the Panavia Tornado in the mid-1980s.

Beyond its service in France and the United Kingdom, the Jaguar found success on the export market, with variants serving in the air forces of India, Oman, Ecuador, and Nigeria. The aircraft saw combat in various conflicts, including operations in Mauritania, Chad, Iraq, and Bosnia. Notably, both the French and British Jaguars were active during the Gulf War in 1990-1991, where they were praised for their reliability and effectiveness in coalition operations.

The Jaguar remained in operational service with the French Air Force until 1 July 2005 and with the RAF until the end of April 2007. In both air forces, it was succeeded by more advanced aircraft. As of 2025, the Jaguar continues to serve with the Indian Air Force, underscoring its enduring legacy and adaptability.

Developer notes

This project has been a year-long adventure, pushing our limits as we have done with each of our previous aircraft. Developing the SEPECAT Jaguar was both a challenge and a passion, as we strived to recreate this legendary machine with the highest level of accuracy and authenticity.

The arrival of Flight Simulator 2024 introduced technical uncertainties that initially delayed our work. However, in hindsight, this extra time allowed us to refine every aspect of the aircraft, ensuring a far more polished and immersive experience than we had initially envisioned.

Bringing to life an iconic symbol of 1970s and 1980s aviation has been a true pleasure. The Jaguar's history, design, and legacy make it a remarkable aircraft, and we hope our work does justice to its place in aviation history.

This project would not have been possible without the support of the Musée Européen de l'Aviation de Chasse (MEACMTL), who welcomed us and gave us the opportunity to access their Jaguar. Their trust and collaboration have been invaluable in ensuring the accuracy of this aircraft.

We are incredibly honored to have been chosen by Dassault Aviation to develop the first officially licensed Dassault fighter for Flight Simulator, with the collaboration of Jet Fighter Experience. This milestone is a major achievement for our team, and we are proud to bring such an iconic aircraft to the virtual skies with their official endorsement.

A special thank you goes to Neil Atterbury, whose dedication to restoring Jaguar XX764 has been truly inspiring. His extensive collection of photos and videos has been instrumental in refining the details of our model. We highly recommend visiting [his website](#) to follow the restoration journey of this legendary aircraft.

Many thanks to the [Bentwaters Cold War Museum](#) for providing us all those pictures and sound recordings which helped us a lot for the development. We are very impressed about their mission of keeping the Jaguar XX741 in flight condition.

Finally, we extend our deepest gratitude to our passionate and supportive community. Your enthusiasm, feedback, and encouragement have pushed us to deliver our best work. This project is as much yours as it is ours!

This manual is written based on real Jaguar documentation (A and GR1 versions) we had access to while developing the aircraft. It has been adapted to apply to our representation in the simulator.

 **INFO**

This manual covers both the Jaguar for MSFS 2020 and the native version for MSFS 2024. Both products share most of their features, hence we decided to write a single manual for them. For the features specific to MSFS 2024, a section has been added at the end of the manual.

General description

Specifications

Weights	
Empty weight	16,130 lbs / 7,315 kg
Maximum takeoff weight	32,630 lbs / 14,800 kg
Dimensions	
Wingspan	28.5 ft / 8.69 m
Length	55.2 ft / 16.83 m
Height	16 ft / 4.89 m
Wing area	258.3 sq ft / 24 m ²
Engines	
Type	Rolls-Royce/Turbomeca Adour Mk.102
Number	2
Maximum thrust	7,150 lbf / 3,240 kgf
Rated N2 speed	15,510 RPM
Fuel capacity (internal)	1,105 gal / 4,185 L
Fuel capacity (external, per tank)	315 gal / 1,195 L
Limits	
Service ceiling	45,000 ft
Maximum speed	Mach 1.4
Maximum range	Around 1,600 nm

Detailed views

You will find in this section the different parts of the cockpit with their respective functionalities. Please refer to next sections to get more detailed information about each separate system. If needed, you can enable tooltips in your simulator to get a description when hovering buttons, knobs and switches.

Main panel



#	Description	#	Description
1	Autopilot buttons	34	Variometer
2	F1 and F4 tanks valves switch	35	Secondary attitude indicator
3	Radar CW/TWS (INOP)	36	Secondary altimeter
4	Yaw deflection switch & indicator	37	Weapons safety knob
5	Radio altimeter	38	Camera obturator mode switch (INOP)
6	Flares light (INOP)	39	Heading control panel
7	Fuel jettison switch	40	Fuel flow indicator

#	Description	#	Description
8	Spoilers extended light	41	Fuel level indicator
9	Master alarm light	42	Left engine tachometer
10	Hydraulic gauge reading switch	43	Right engine tachometer
11	AJAX gain selector	44	Left engine thrust increase light (INOP)
12	Hydraulic pressure gauge	45	Right engine thrust increase light (INOP)
13	Hydraulic electro-pump switch & light	46	Left engine exhaust gas temperature indicator
14	Machmeter	47	Right engine exhaust gas temperature indicator
15	Differential deflection handle	48	Left engine fire light & extinguisher button
16	AJAX mode switch	49	Right engine fire light & extinguisher button
17	Pitch trim indicator	50	Left afterburner fire alarm light
18	Flaps and landing gear state panel	51	Right afterburner fire alarm light
19	Altimeter	52	Exhaust nozzles position
20	Slats mode button & light	53	Fuel totalizer
21	Nosewheel steering engaged light	54	Fuel control panel
22	Emergency stores release button	55	Engines fuel crossfeed switch
23	Emergency landing gear handle	56	Alarm sound disable switch
24	Landing gear handle	57	Engine thrust increase switch (INOP)
25	Landing gear crash button	58	Refueling probe knob
26	Altitude calibration panel (INOP)	59	Refueling probe state lights
27	COM panel	60	Alarms test/mute switch
28	Anti-flash lights	61	Alarms day/night switch
29	Sphere indicator	62	Alarms panel
30	Navigation indicator	63	Anti-flash light
31	Sphere radionav indication switch	64	Parking brake handle

#	Description	#	Description
32	Tailhook extended light	65	Oxygen indicator
33	IFF mode 4 light (INOP)	66	Battery voltmeter

Lower panel



#	Description	#	Description
1	Fuel low pressure valves switches	7	APU bleed air switch

#	Description	#	Description
2	Hydraulic power transfer switches	8	APU bleed air light
3	Fuel feed and transfer pumps switch	9	Engines starter switch
4	EGT measure amplifier switches	10	Engines correct rotation lights
5	APU mode switch	11	Cabin altitude indicator
6	APU starter button & light		

Overhead instruments

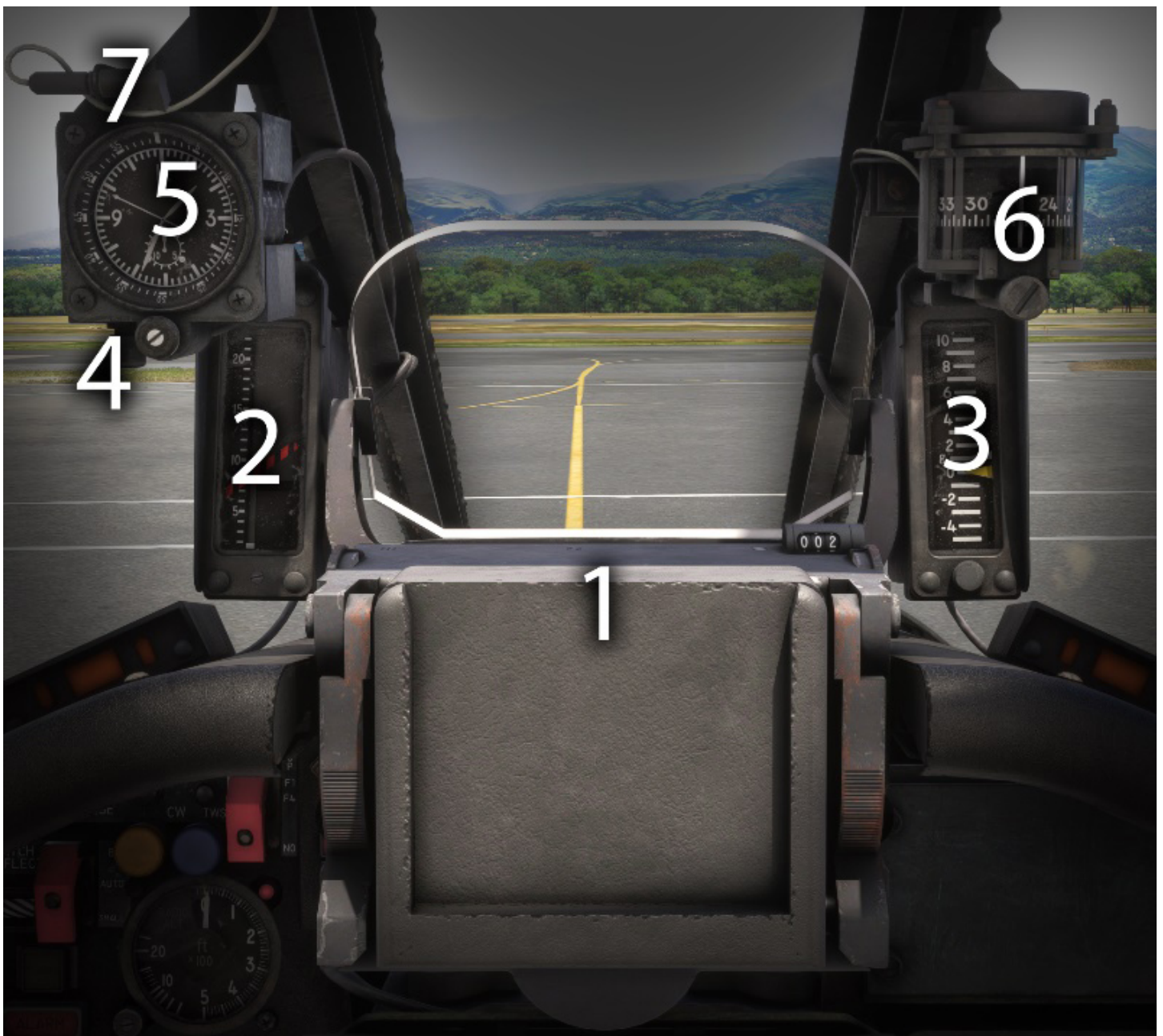

#	Description	#	Description
1	Heads up display (HUD)	5	Clock / chronometer
2	Angle of attack indicator	6	Standby compass
3	Accelerometer	7	Frontal instrument light
4	Frontal instruments lights knob		

Right console

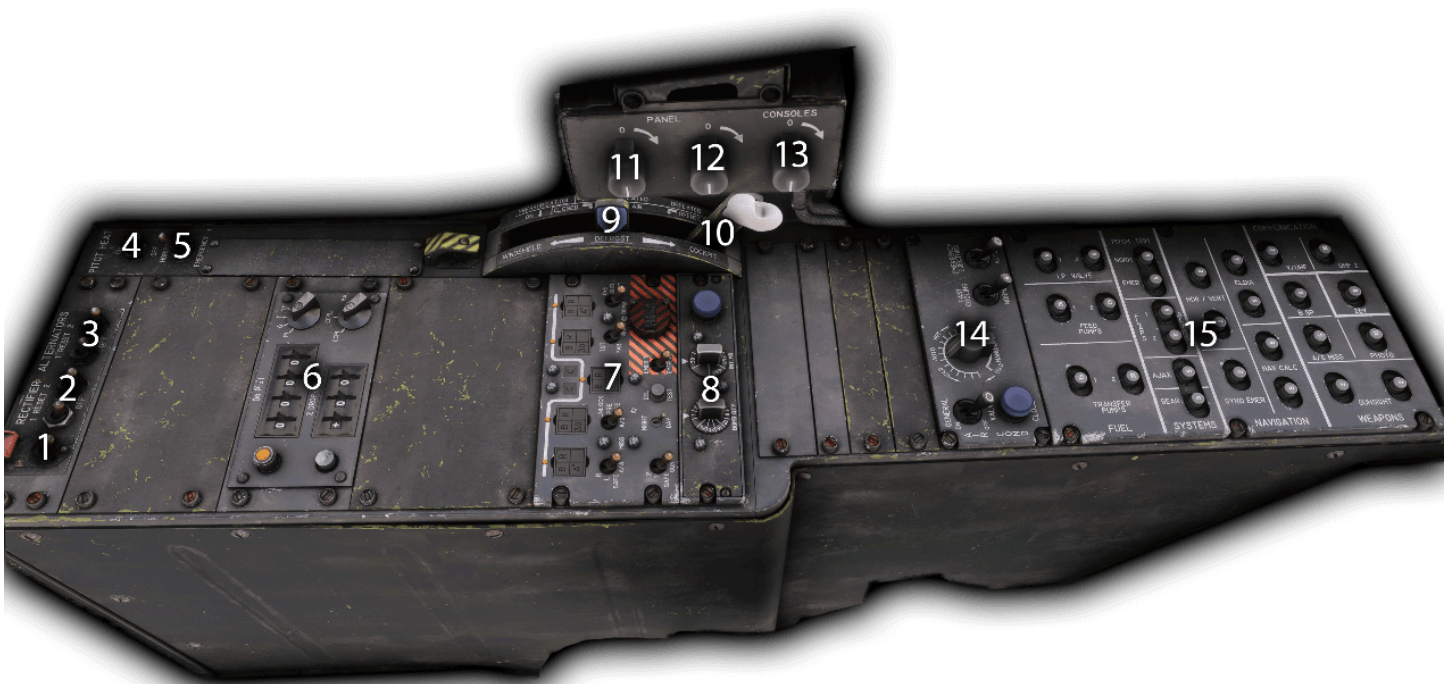

#	Description	#	Description
1	Master battery switch	9	Windshield/cockpit defrost handle
2	Rectifiers switches	10	Canopy seal & pressurization lever
3	Alternators switches	11	Front panel red lights knob
4	Pitot heat switch	12	Front panel UV lights knob
5	Secondary attitude indicator power switch	13	Consoles red lights knob
6	Ballistic computer panel	14	Air conditioning panel
7	Payload selection panel	15	Main electrical breakers panel

#	Description	#	Description
8	Intervalometer panel		

Left console

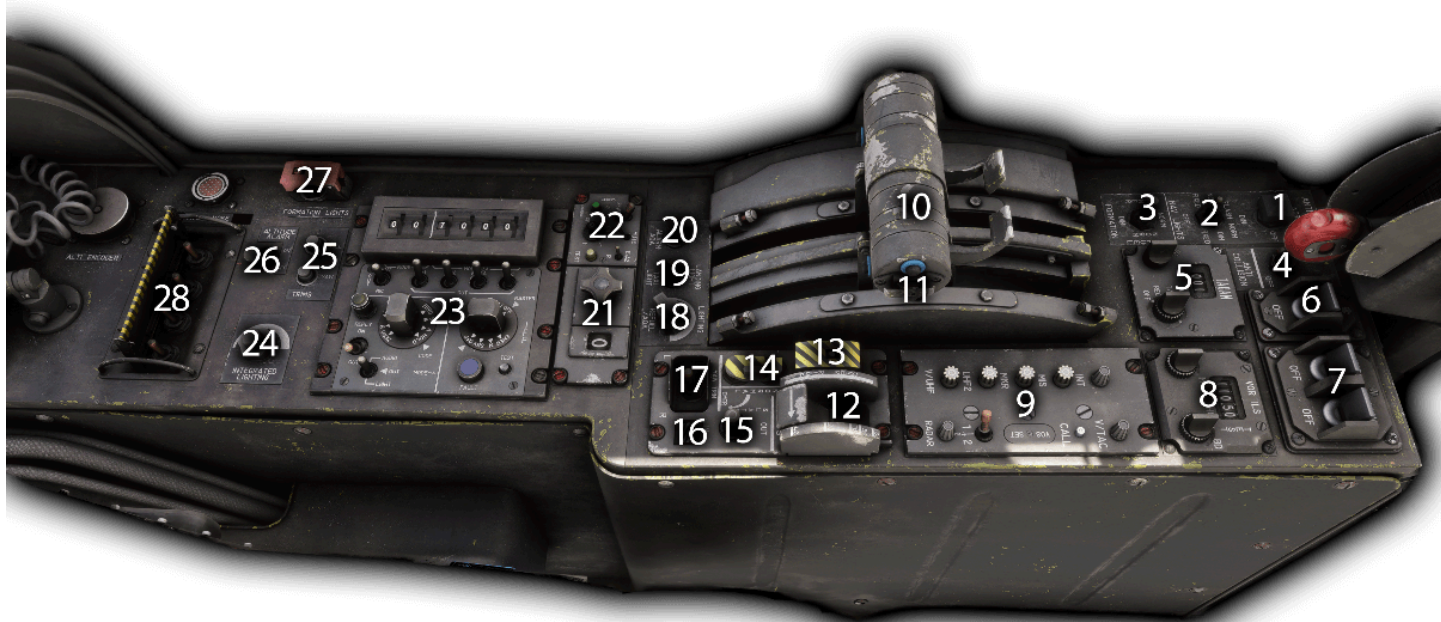

#	Description	#	Description
1	Anti-flash lights switch	15	Slats manual mode switch
2	Navigation lights switch	16	Rudder trim indicator
3	Formation/refueling lights switch	17	Rudder trim switch
4	Anti-collision lights switch	18	Refueling /AOA lights intensity knob
5	TACAN panel	19	Taxi & landing lights switch
6	Roll stabilization switch	20	AOA alarm switch
7	Pitch & yaw stabilization switch	21	UHF2 channel preset knob
8	VOR/ILS panel	22	UHF2 panel
9	Intercom panel	23	IFF (transponder) panel
10	Throttle levers	24	Integrated lights knob

#	Description	#	Description
11	Spoilers selector	25	Yaw/roll trim electrical breakers
12	Flaps selector	26	Altitude alarm switch
13	Emergency flaps switch	27	Retracted probe refueling lights setting
14	Emergency pitch trim switch	28	Crash bar

Upper left console

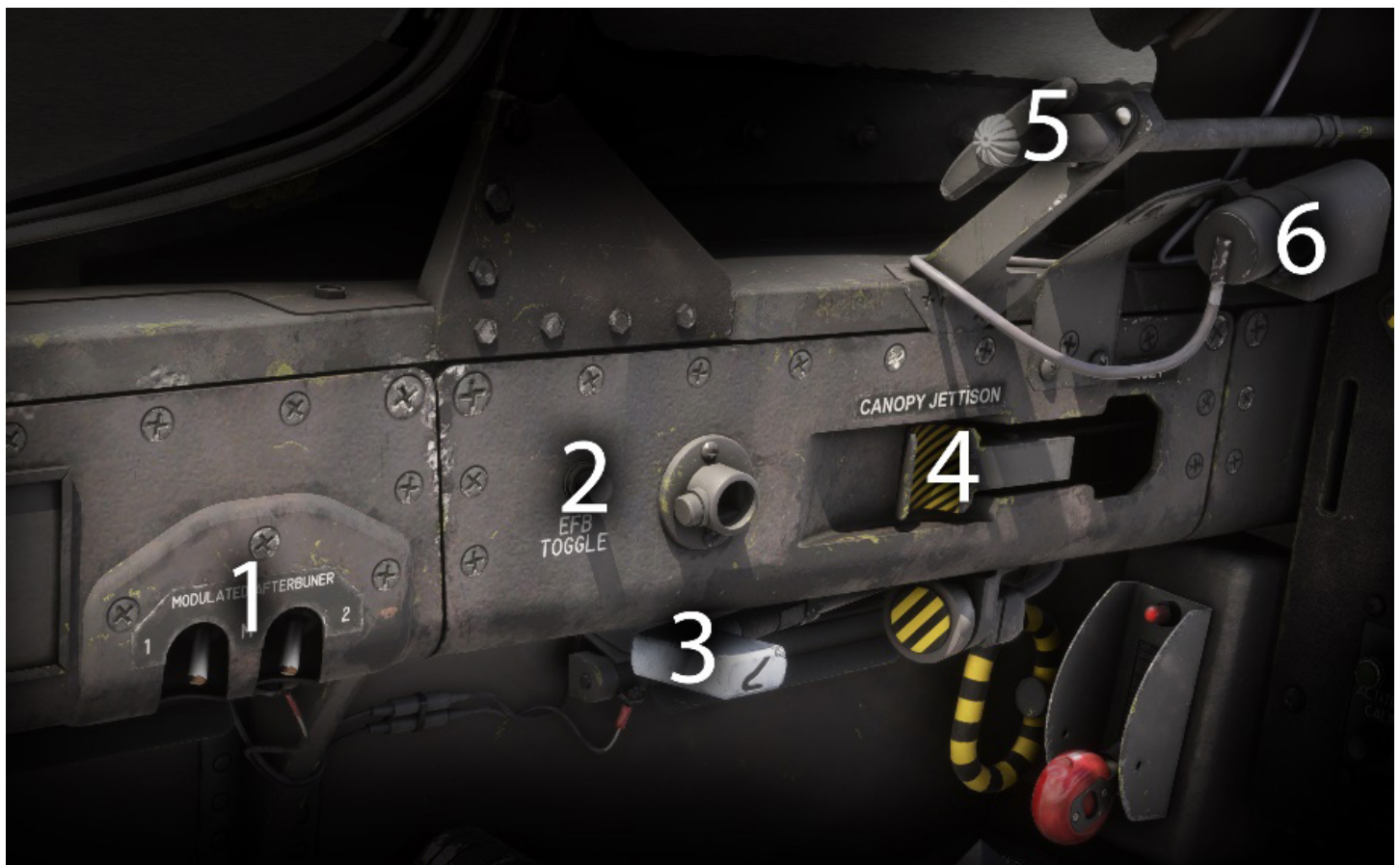

#	Description	#	Description
1	Modulated afterburner switches (INOP)	4	Canopy jettison handle
2	EFB/tablet toggle switch	5	Drag chute handle
3	Tailhook handle	6	Anti-flash light

Engines and auxiliary power

Engines

The Rolls-Royce Turbomeca Adour is a two-shaft, low bypass, twin-spool turbofan engine.

The Jaguar A and early GR1 versions were equipped with the Mk.102 version, which features an afterburner.

This engine has the following specifications:

Max dry thrust	5,160 lbf / 2,295 daN
Minimum afterburner thrust	6,700 lbf / 2,980 daN
Maximum afterburner thrust	7,380 lbf / 3,285 daN
Main characteristics	
Engine weight	1,667 lbs / 756 kg
Bypass ratio	0.85
Total airflow	92 lbs/sec / 41.7 kg/sec
Low-pressure compression ratio	2.6
Overall compression ratio	9.6
Low pressure spool speed	13,600 RPM at 100% N1
High pressure spool speed	15,510 RPM at 100% N1
Rotation direction	Counter-clockwise (rear view)
Ambient temperature impact	10% thrust loss between +18 °C and +30 °C
Bleed air impact	Approx. 3% thrust reduction per engine
Fuel consumption	
Max dry fuel flow	72 lbs/min / 32.6 kg/min
Max afterburner fuel flow	265 lbs/min / 120 kg/min

Each engine is housed in a dedicated compartment on either side of the central fuselage beam. A fireproof bulkhead divides each compartment into two sections:

- Zone 1, which contains the core engine.
- Zone 2, which includes the afterburner duct and exhaust nozzle.

Both zones are equipped with fire detection systems, but only zone 1 has a fire suppression system.

i NOTE

The original engine has a special feature called modulated afterburner, allowing to use reheat before the maximum dry thrust position. This feature is not simulated as the simulator does not support it.

Also, the "thrust increase" feature used for take-off in high-temperature (3-9% thrust increase) is not simulated.

Throttle

The engines are controlled by two throttle levers positioned on the left console. Each throttle lever controls the opening or closing of the high-pressure fuel valve of the corresponding engine, and allows thrust modulation with afterburner selection.

The range of motion for each throttle lever includes a dry thrust section and an afterburner section, with the following key positions from aft to forward:

- Engine shutoff (HP fuel valve closed).
- Idle (or start position).
- Full dry thrust.
- Minimum afterburner.
- Maximum afterburner.

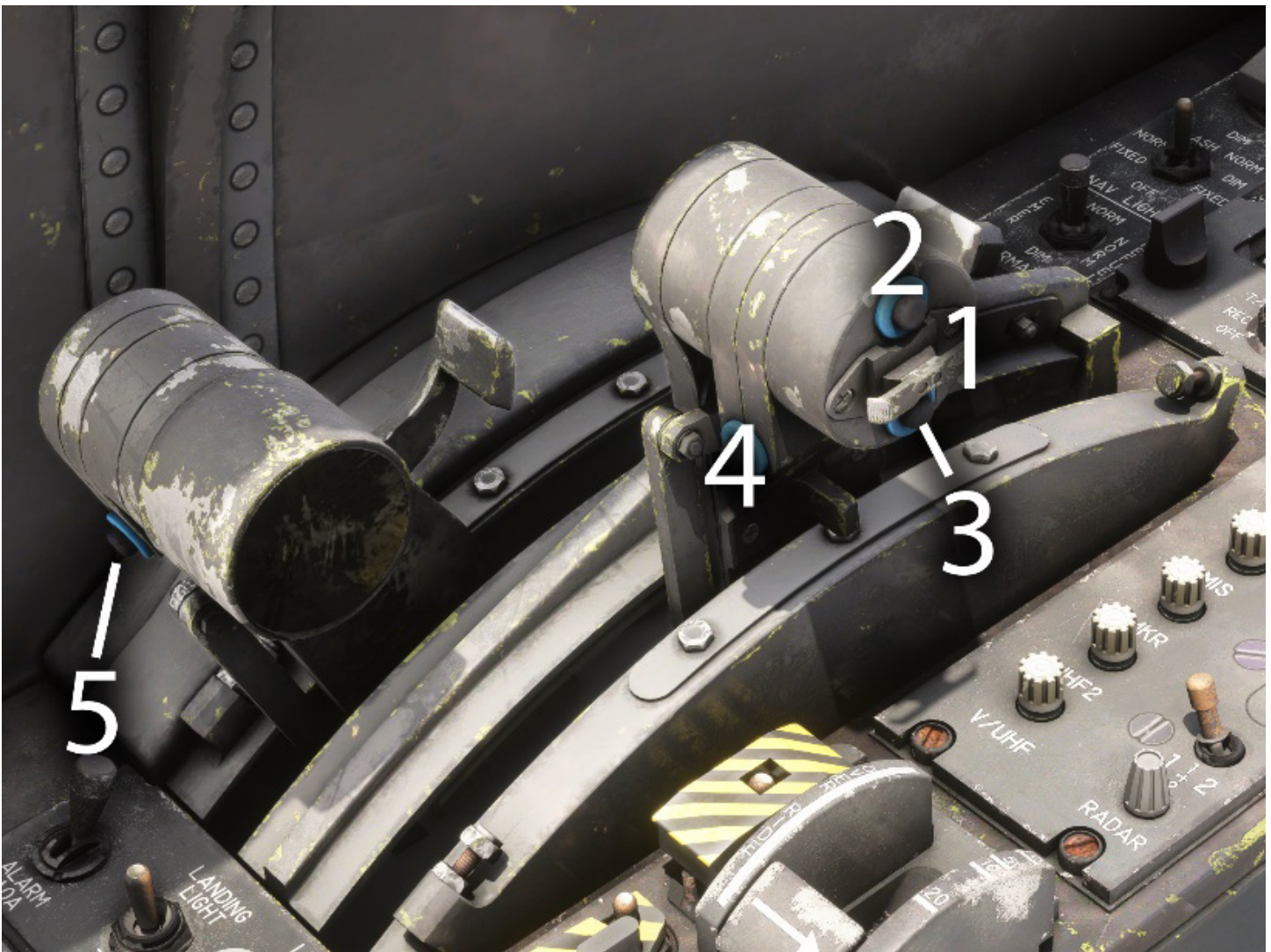

#	Description	#	Description
1	Spoilers switch	4	Right engine restart button
2	Flares fire button (INOP)	5	Left engine restart button
3	Flares fire button (INOP)		

When operating the throttles with mouse in Flight Simulator, you need to maintain the throttle (left click) and do a right click to trigger shutoff and afterburner positions.

You can also bind your controller to trigger afterburner using a button (see controls options menu).

There is no existing binding in the simulator to go to fuel cut-off position. If you are using an external binding software (like FSUIPC), you can reach this position using the following B events:

B:ENGINE_Throttle_1_Idle and *B:ENGINE_Throttle_2_Idle* (for left and right engine respectively).

Shutoff position

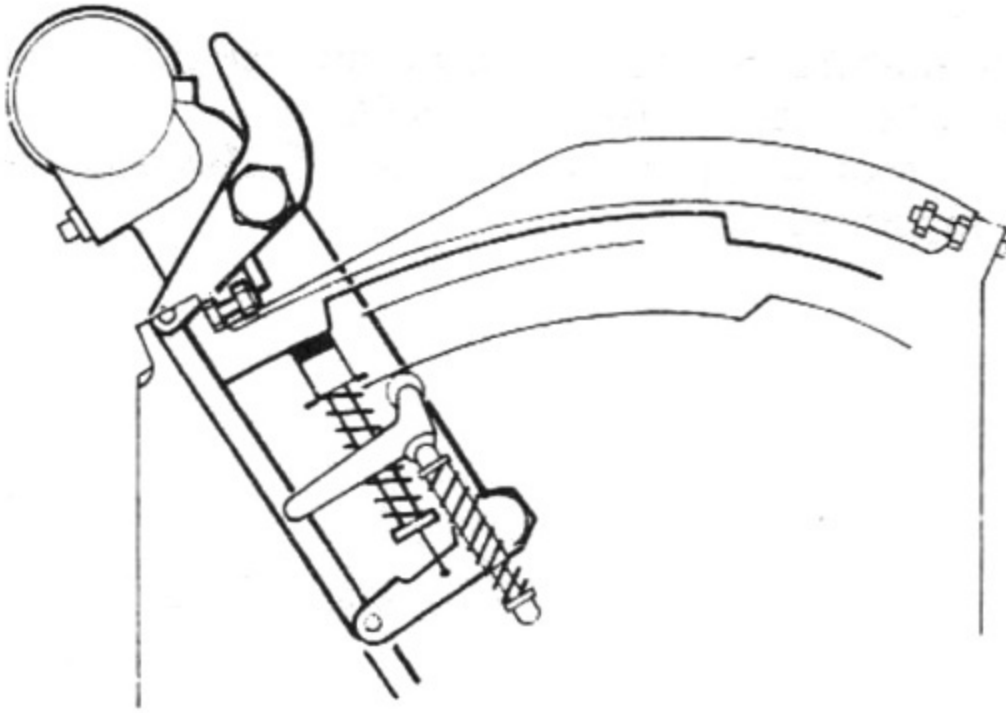

The throttle lever is in the fully aft position. The retractable stop override paddle is in the raised position, and the fixed stop on the lever arm rests against the rear stop of the housing. This position allows to shut down the engine.

Idle/start position

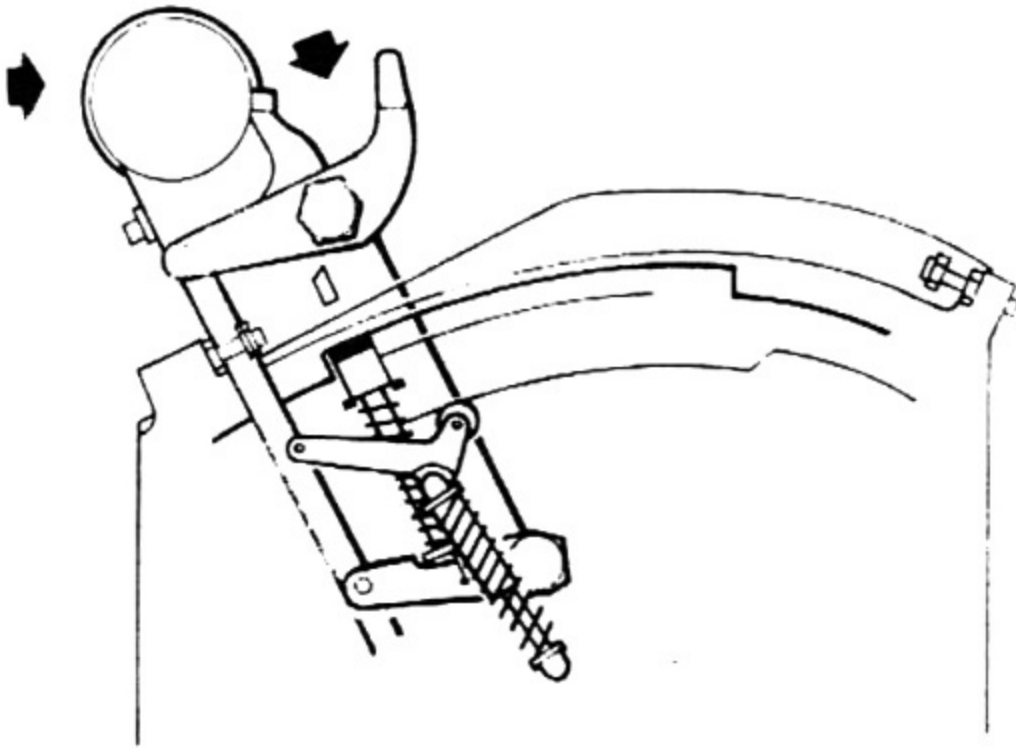

Push the throttle lever forward until the retractable stop, actuated by its spring, engages in the dry detent ramp and rests against the rear notch of this ramp. The stop paddle returns to the lowered position.

Maximum dry thrust position

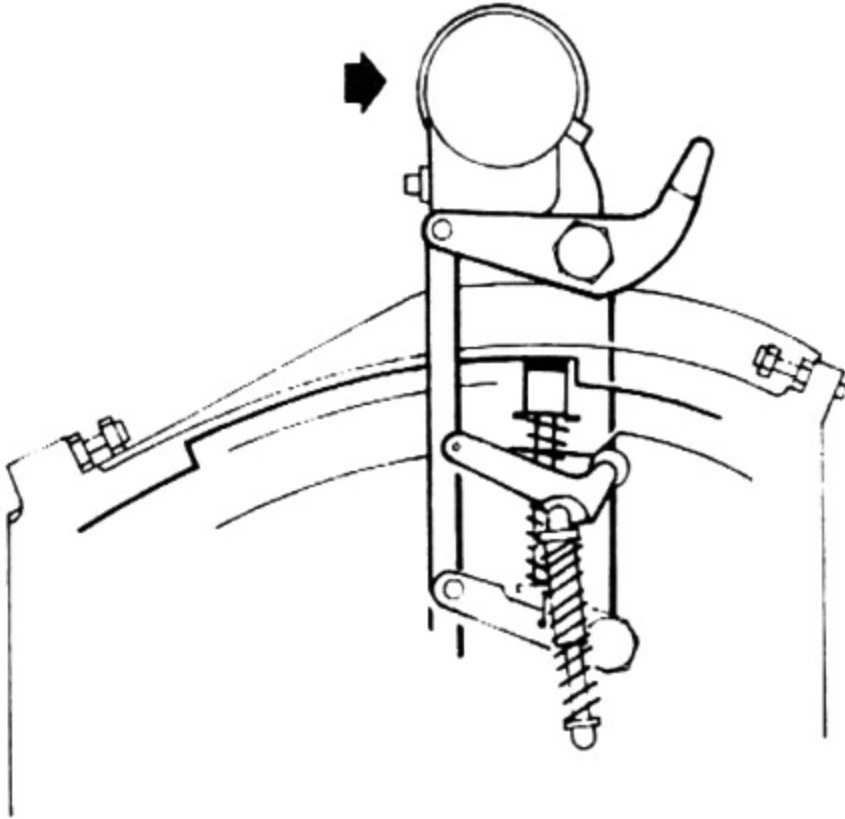

Starting from idle, push the throttle lever forward until the retractable stop engages with the forward notch (full dry thrust) of the dry ramp.

Afterburner ignition and maximum afterburner position

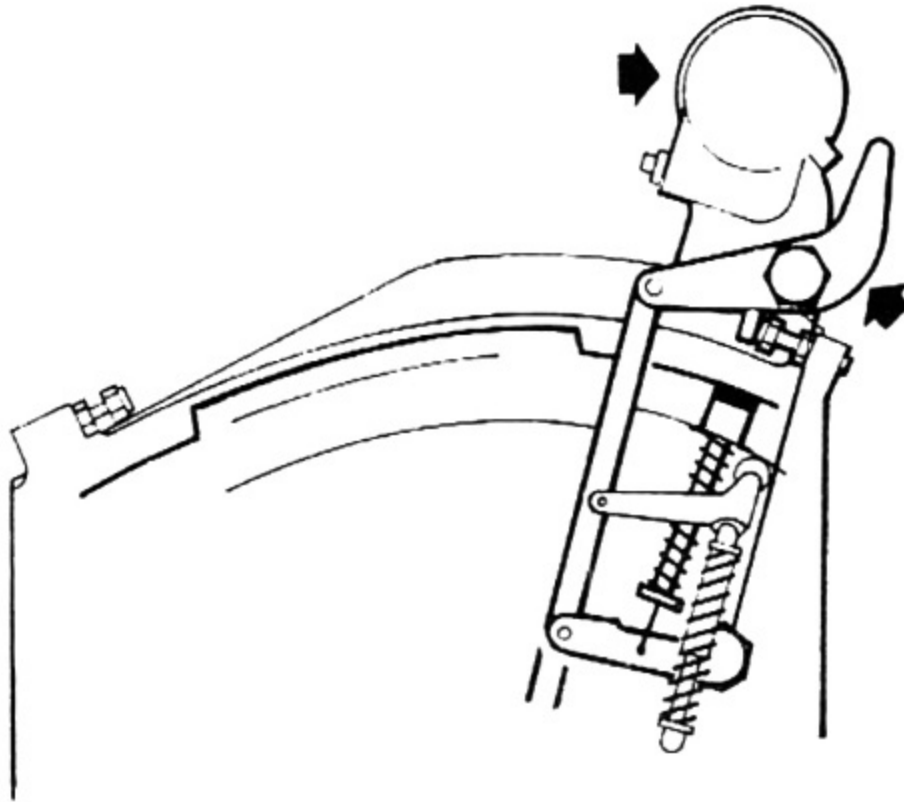

To pass the full dry thrust notch, operate the paddle (set it to the raised position). The retractable stop disengages, allowing the throttle lever to move into the afterburner range until the fixed stop on the throttle rests against the forward stop of the housing.

Throttle lever return to minimum afterburner stop

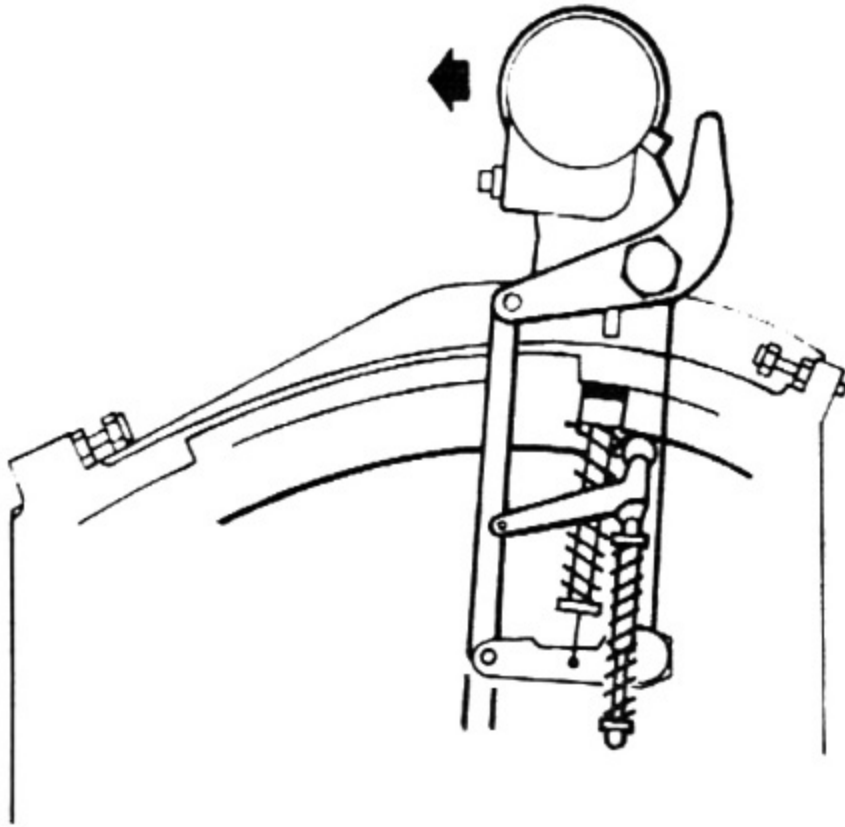

From the maximum afterburner position, pull the throttle lever back until the roller on the pivoting support rests against the notch of the lower afterburner ramp.

Afterburner cutoff

Move the throttle lever rearward into the dry thrust range. This maneuver involves:

- Passing the minimum afterburner notch with the pivot support roller.
- Releasing the retractable stop, which returns to the dry ramp after clearing the full dry thrust notch.
- The stop override paddle returning to the lowered position.
- The throttle lever can then be pulled back to the idle position.

Throttle lever return to engine shutoff position

Operate the stop override paddle (set it to the raised position) to lower the retractable stop, then pull the throttle lever back until the fixed stop on the lever arm rests against the rear stop of the housing (position 1 – engine shutoff).

Exterior components

Intake flaps

The air intake ramps, part of the propulsion system, each have two air inlets doors on the sides, designed to improve engine airflow at low speeds.

Their operation is automatic, depending on the air pressure/vacuum at the engine intake. At idle on the ground, it is normal for the flaps to open slightly, while at high speeds, they will fully close to optimize airflow.



Variable position nozzle

The variable-area nozzle is controlled by overlapping flaps, connected to a command ring via rollers. Four actuators, powered by high-pressure fuel, adjust the nozzle opening.

In dry thrust mode, the flaps remain closed. When the afterburner is engaged, their position varies between partially open and fully open to maintain optimal exhaust pressure and ensure the turbine operates within safe detachment limits.

A sensor provides an electrical signal to indicate the nozzle position.



Auxiliary power

The Jaguar has an auxiliary power unit (APU) in order to provide compressed air for engine starting. This small gas turbine is located in the left airbrake compartment and is called "Microturbo".

This turbine can only be powered with the airbrakes deployed. For this reason, airbrakes are usually extended before shutting down the engines, in order to facilitate the next start.

The fuel feeding the APU is collected at the upstream of right engine low-pressure valve.

The APU can be stopped manually or automatically in the following scenarios:

- Startup takes more than 20 seconds.
- It has been running for more than 10 minutes.
- Both engines are started (RPM above 39% N1).

Engines operation

Startup

Startup is managed from the panel described [here](#).



MSFS 2024 NATIVE VERSION ONLY

You must not forget to remove engine covers, which would prevent the engines from rotating, as described [here](#).

With the airbrakes extended and the fuel feed and transfer pumps switch set to ON, APU master switch must be set to ON position, then the starter button should be pressed.

The APU starts and stabilizes at idle; generated bleed air is vented outside.

As specified in the previous section, airbrakes must be fully opened during ground start. A safety switch prevents the startup of the APU otherwise.

Setting the "START" selector to "ENGINE 1" (or "ENGINE 2") opens the air supply valve, allowing engine start. Simultaneously, the vent valve closes (the "VALVE OP" light illuminates). The air starter then drives the high-pressure spool, which induces airflow to start the low-pressure spool.

When the "CORRECT ROTATION" light turns on, meaning engine is rotating, throttle lever is moved to the ground start/idle detent.

Once the engine reaches the starter cutout speed (approximately 39% N1), the air supply valve closes and the vent valve reopens ("VALVE OPEN" light turns off). At the same time, the "CORRECT ROTATION" light goes off, and the igniters deactivate.

After the second engine start, APU shuts down automatically ("START" light turns off).

Monitoring

Several instruments in the cockpit are used to monitor the engines. In addition, **several alarms** are related to engines alerts.

Tachometers

Each tachometer is powered by a tachometric generator and indicates the high-pressure spool rotational speed in %.



EGT Indicators

Each engine is equipped with seven thermocouple probes that measure the exhaust gas temperature downstream of the low-pressure turbine.



EGT amplifier switches can have an impact on the temperatures reached. On normal position (ON), it enables automatic regulation of the limit temperatures, and restricts the maximum speed of the low-pressure spool (by reducing fuel flow).

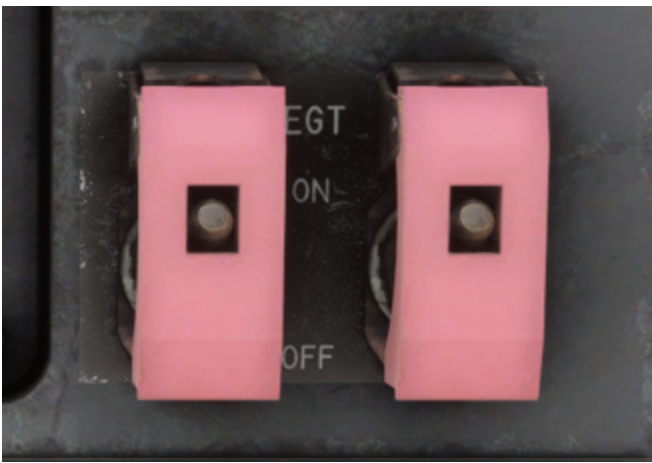

Nozzle position indicator

This indicator is graduated from 0 to 10 (no unit).

It allows to control the position of exhaust nozzle (left and right):

- 0 → idle to full dry thrust.
- 4 → minimum reheat.
- 6 to 8 → maximum reheat.



Fuel Flow indicator

This gauge indicates fuel flow for both engines:

- Idle → around 3 kg/min.

- Full dry thrust → around 30 kg/min, depending on conditions.
- Afterburner → orange zone, more than 100 kg/min.

Indicator #2 also displays APU consumption (around 2 kg/min in normal conditions).



Fire

There are four independent fire detection circuits, one per zone (engine core, afterburner section) and per engine.

In case of hot gas leakage or fire, one of the detectors sends a signal to the control unit, which illuminates the corresponding fire warning light, triggers the audible alarm, and causes the master alarm light to flash.



Fire detection testing is performed using the TEST switch above alarms panel.

The extinguishing system includes:

- A dual-head fire extinguisher bottle, equipped with two percussion cartridges.
- Four distribution manifolds (two per engine), ensuring full saturation of zone 1 in case of fire. Each side is supplied by two pipelines connected to the extinguisher bottle.
- Two percussion control buttons, concealed under covers, integrated into the fire warning lights of zone 1.
- A crash bar, enabling simultaneous activation of both extinguishers.

Fuel system

The Jaguar has a complex fuel system consisting of eight internal tanks, with the possibility to add up to three external tanks.

Fuel transfer is conducted automatically during the whole flight to ensure the aircraft is always centered correctly.

Description

Internal tanks are separated in three groups: forward, central, back.

Group	Tank name	Capacity	Weight (TR4 fuel)
Forward	N1	40 gal / 150 L	254 lbs / 115 kg
	N2	40 gal / 150 L	254 lbs / 115 kg
	F1	165 gal / 625 L	1,060 lbs / 481 kg
Central	V1	258 gal / 975 L	1,656 lbs / 751 kg
	V2		
	F2	301 gal / 1,140 L	1,936 lbs / 878 kg
	F3		
Back	F4	302 gal / 1,145 L	1,942 lbs / 881 kg
TOTAL		1,105 gal / 4,185 L	7,103 lbs / 3,222 kg

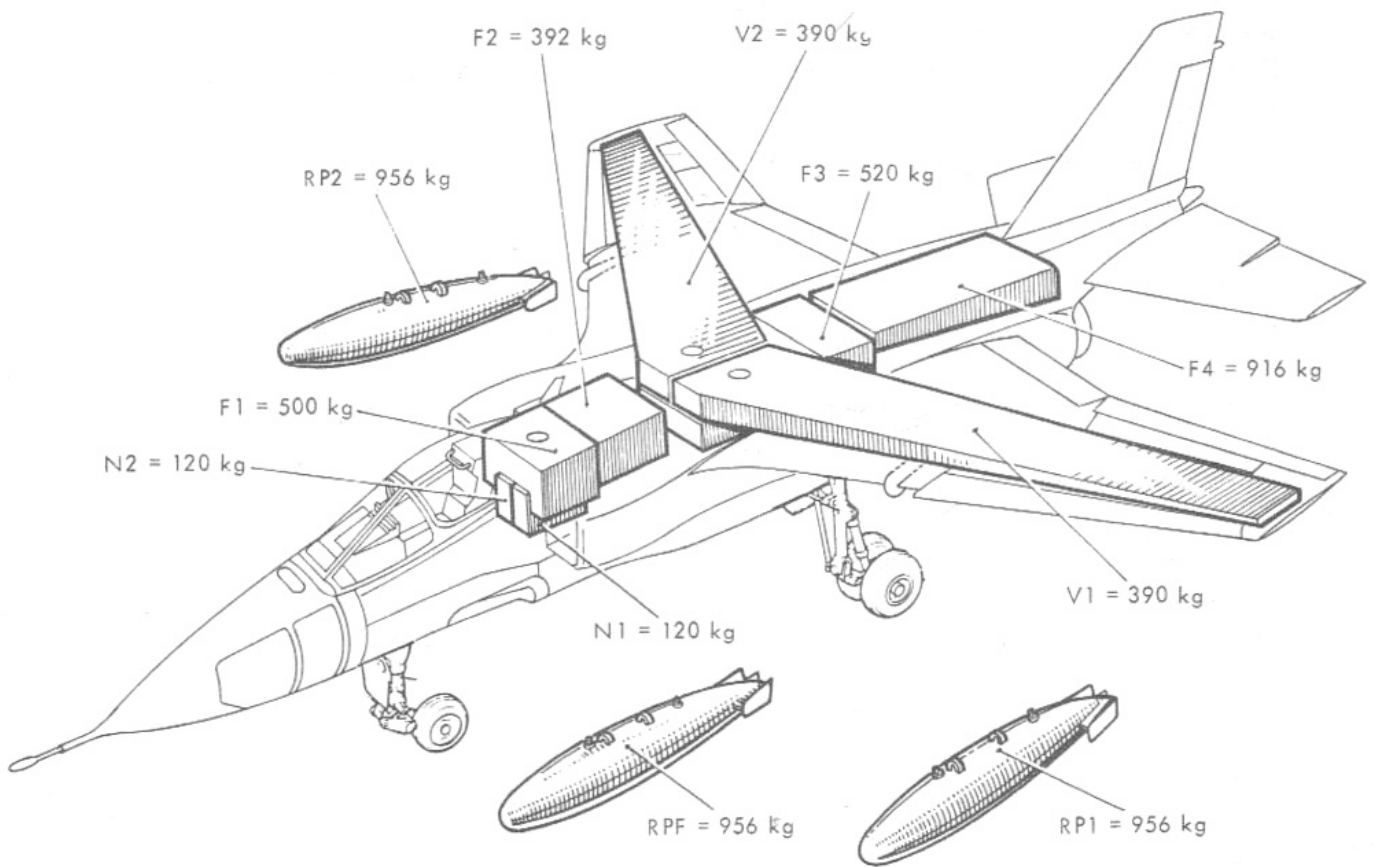

N1 and N2 tanks are connected to left and right engine (respectively). They are the only tanks having a flexible structure.

F2 and F3 tanks are directly connected. Transfer between other tanks is managed with the help of several electro-valves.

All tanks (except N1, N2, F2/F3 and F4 which enclose transfer pumps) are pressurized with air taken from the engines.

Here is a diagram of the circuit:

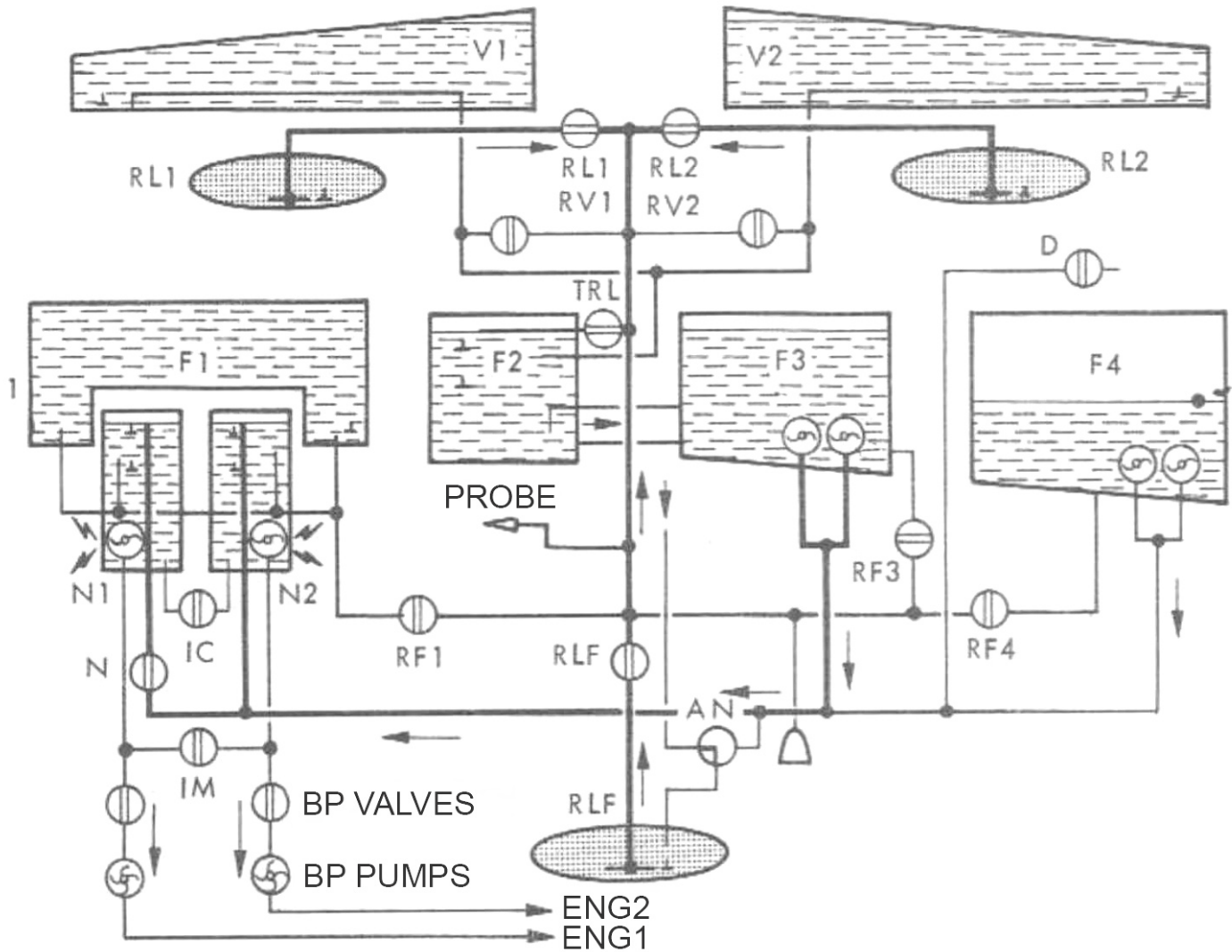

To follow fuel quantity remaining in each tank, a gauge on main panel shows the following information:

- "F" (front) gauge represents fuel weight in F1, N1 and N2 tanks (cumulated).
- "R" (rear) gauge represents fuel weight in F4.

A blue zone on the first needle shows the sector where "AR" needle should remain in order for the aircraft to be correctly centered. The automatic fuel transfer is made to stay in this tolerance zone.



In addition, fuel control panel shows for each tank if it is full, partially full or empty, as described [here](#).

After each refuel, a totalizer is set by the pilot to display the total fuel weight embarked in the aircraft. This totalizer is automatically updated with fuel consumption to show at any time the total fuel remaining. Jettisoned fuel is not taken into account by the totalizer. The totalizer does not show the units which stay at zero.



A button on the EFB allows to set the totalizer automatically.

External fuel

Both A and GR1 have the same 1,195 liters external tanks (slightly different design, but same capacity).

The aircraft can carry up to three external tanks (one on the belly, one below each wing).

External tanks can be added from the EFB (fuel page or weapons page).

In case of emergency during the flight, they can be jettisoned with all other external stores from a button above left console.



Fuel transfer

Fuel transfer is conducted automatically during the whole flight, in order to keep the aircraft centered.

A small panel allows to monitor and manage everything related to the fuel system:

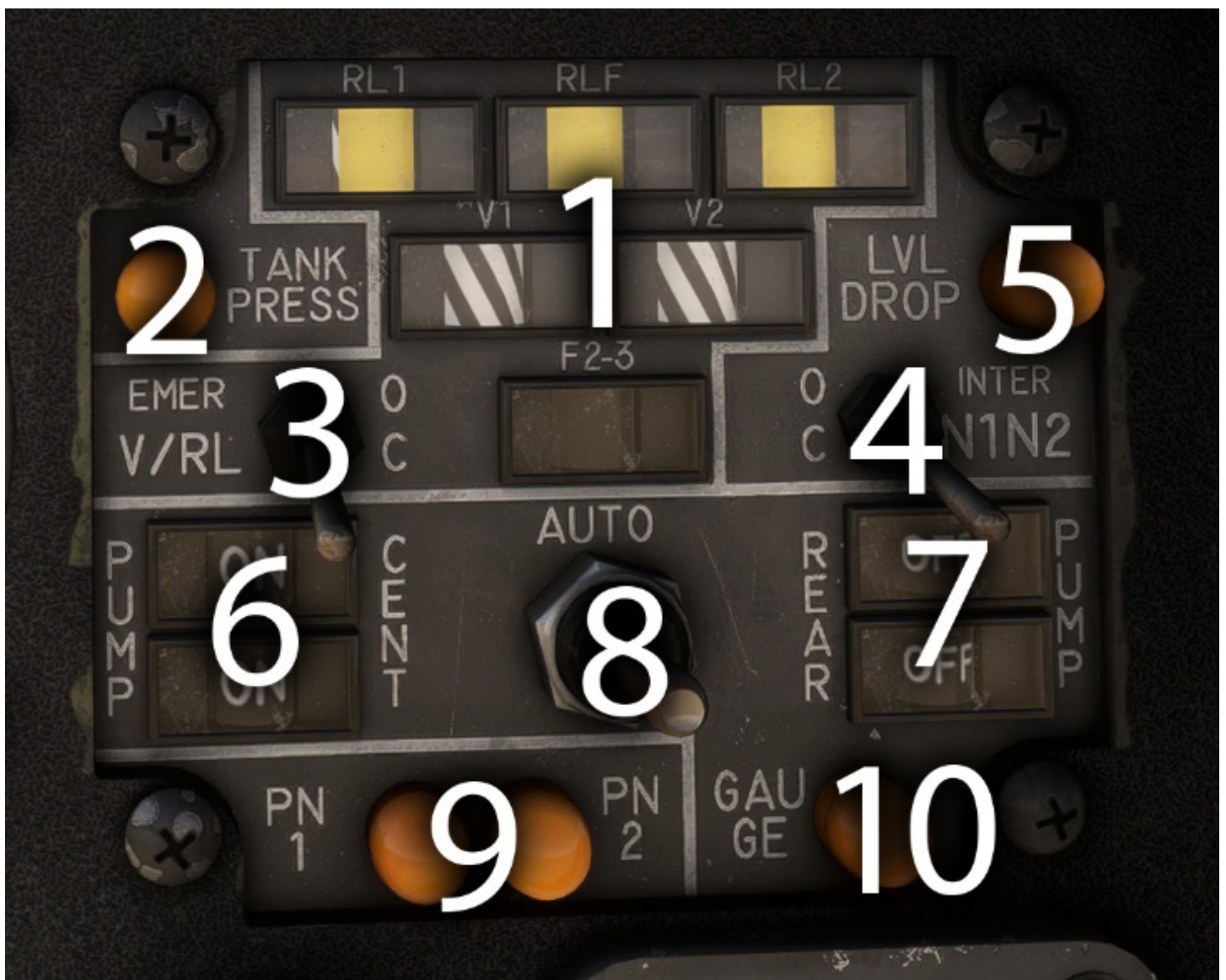

#	Description	#	Description
1	Fuel tanks level indicator (three states)	6	F3 pumps active
2	Tanks pressurization failure light	7	F4 pumps active
3	V1 and V2 valves emergency opening	8	Transfer pumps mode (F3 – AUTO – F4)
4	N1 and N2 intercom valve opening	9	Feed pump failure (N1/N2)
5	Level dropping in N1/N2 light	10	Fuel transfer anomaly light

As fuel quantity gauge does not show the exact quantity in all fuel tanks, fuel tank indicators show in the other tanks (RL1, RLF, RL2, V1, V2 and F2/F3) the following:

- Yellow background if tank is empty.
- Zebra pattern background if tank is partially filled.

- Black background if tank is full.

Tanks are emptying following this sequence:

- F4 fuel is transferred to N1 and N2 using the two immersed pumps, until 475 kg (1,047 lbs) of fuel remains in F4. At this moment, "R" needle is located on "F" needle mark.



- F3 fuel is transferred to N1 and N2 using the two immersed pumps. As F2 is connected to F3, it results in the consumption of fuel contained in external tanks (RL1, RL2, RLF) and in wing tanks (V1, V2). Once F3 is empty, immersed pumps are stopped. Only fuel remaining is in F1, F4, N1 and N2.
- F4 pumps are supplied again and F1 valves are opened in order to empty F1 and F4 tanks at the same time.
- N1 and N2 tanks are feeding the engine. "N1-N2" alarm will be triggered when 200 kg (441 lbs) of fuel is remaining in the aircraft.

Please note that N1 and N2 intercom valve is not always opened. In the case where only fuel remaining is inside N1 and N2, you may need to open this valve manually from the control panel to ensure both engines are fed.

Fuel dump

In case of emergency, fuel can be dumped in order to reduce aircraft weight prior to landing.

A switch behind a protection hood is used to open fuel dumping valve.



Fuel is ejected from a pipe placed in the rear of the aircraft, above the parachute cone.



Electrical system

Description

Electrical power is produced by two main circuits:

- A/C three-phase network, composed of two buses supplied by two alternators (one per engine).
- D/C network, supplied by A/C buses with two rectifiers. A 24 V battery, nickel-cadmium with a 40 Ah capacity, is used to power this network when both engines are off and alternators are not providing any power.

A/C power generation

The primary 115/200 V, 400 Hz network is supplied by the alternators, which independently feed their respective distribution bars:

- The left alternator powers bus 1.
- The right alternator powers bus 2.

In addition to the various loads connected to these buses, bus 2 also supplies 115 V and 26 V buses.

If one alternator fails, buses 1 and 2 are automatically connected, and the remaining alternator takes over the load.

The alternators are three-phase 115/200 V, 400 Hz, 12 kVA alternators. Each one is driven by the accessory drive gearbox of the corresponding engine. It consists of an electromechanical variable-speed drive, which maintains a constant alternator speed for input speeds ranging from 3,800 to 8,000 RPM. This ensures that the generated current frequency remains stable at 400 Hz \pm 1%.

D/C power generation

The 28 V D/C power is obtained from two transformer-rectifiers, which are powered by A/C distribution buses 1 and 2. The transformer-rectifiers operate in parallel, supplying the distribution buses, which are connected through a contactor controlled by the protection system.

The battery, acting as a buffer, continuously supplies the battery bus. This 40 Ah nickel-cadmium alkaline battery serves as the ultimate reserve of electrical energy in the event of a failure of both variable alternators.

Under normal operation, it is connected to the D/C distribution buses through a circuit breaker contactor. It continuously supplies the "battery" distribution bus and, in the event of a failure of both alternators, it powers the 28/115 V static converter and the emergency DC bus 2.

Ground power

Ground power unit can be selected on the EFB to relieve the battery when aircraft is on ground with both engines off. It is connected on a socket in front of the left gear strut.



Lights

Exterior

The following exterior lights exist on the Jaguar:

- Anticollision (beacon) lights.
- Navigation lights.
- Taxi light.
- Landing light.
- Formation lights (lights on top of wings, used during formation flying).
- Refueling lights (two side lights placed to illuminate refueling probe).

Two beacon lights (top of fuselage & belly) can be powered independently from the same switch on left console:



Navigation lights can be set to four different settings:

- Off.
- Fixed with normal intensity.
- Fixed with dimmed intensity.

- Flashing.

This switch is moved with left click maintained and drag in the desired position.



A common switch (located in front of throttles) is used to manage taxi and landing lights. When landing gear is retracted, those lights are turned off automatically.



Formation lights and refueling lights are managed with a common switch with five positions:

- **OFF.**

- **NORM:** formation lights with full intensity, refueling lights off.
- **DIM:** formation lights with dimmed intensity, refueling lights off.
- **REFUEL NORM:** formation lights with normal intensity, refueling lights on.
- **EMERGENCY:** formation lights off, refueling lights on and forced to maximum intensity.

This switch is moved with left click maintained and drag in the desired position.



A knob allows to set refueling lights intensity. This same knob also commands intensity of AoA indicator light.



By default, refueling lights cannot be used if refueling probe is retracted. A switch behind a hood is used to force refueling lights even in that case:



Interior

Interior lights are the following:

- Panel lights (red and UV setting).
- Console lights (red).
- Integrated lights (white backlighting, for both consoles).
- Instruments lights (red).
- Anti-flash lights (white).

They are made to fly in any conditions, including night.



Panel and console lights can be set at different intensities with three knobs above right console. For instruments panel, red lights or UV lights (or a mix of both) can be chosen.



Integrated lights can be set at different intensities, independently for left and right side of the cockpit (left console):



Please note that integrated lights will also manage backlighting of the GPS units.

Instruments lights are powered with a knob located below the clock:



This light is dedicated to the instruments located above the panel: clock, standby compass, angle of attack indicator and accelerometer.



Anti-flash lights can be set on two different settings (normal or dim) and are illuminating instruments panel with a strong white light:



Alarms

Several alarms (visual and aural) to indicate any abnormal event to the pilot.

Those alarms are divided into different categories:

- Warning (red light).
- Caution (amber light).
- Other alarms.

In order to avoid any alarm indication failure, each alarm is using two lights connected in parallel.

Alarms panel

Alarms panel is located on bottom left part of instruments panel. It gathers all main alarms (warning and caution).

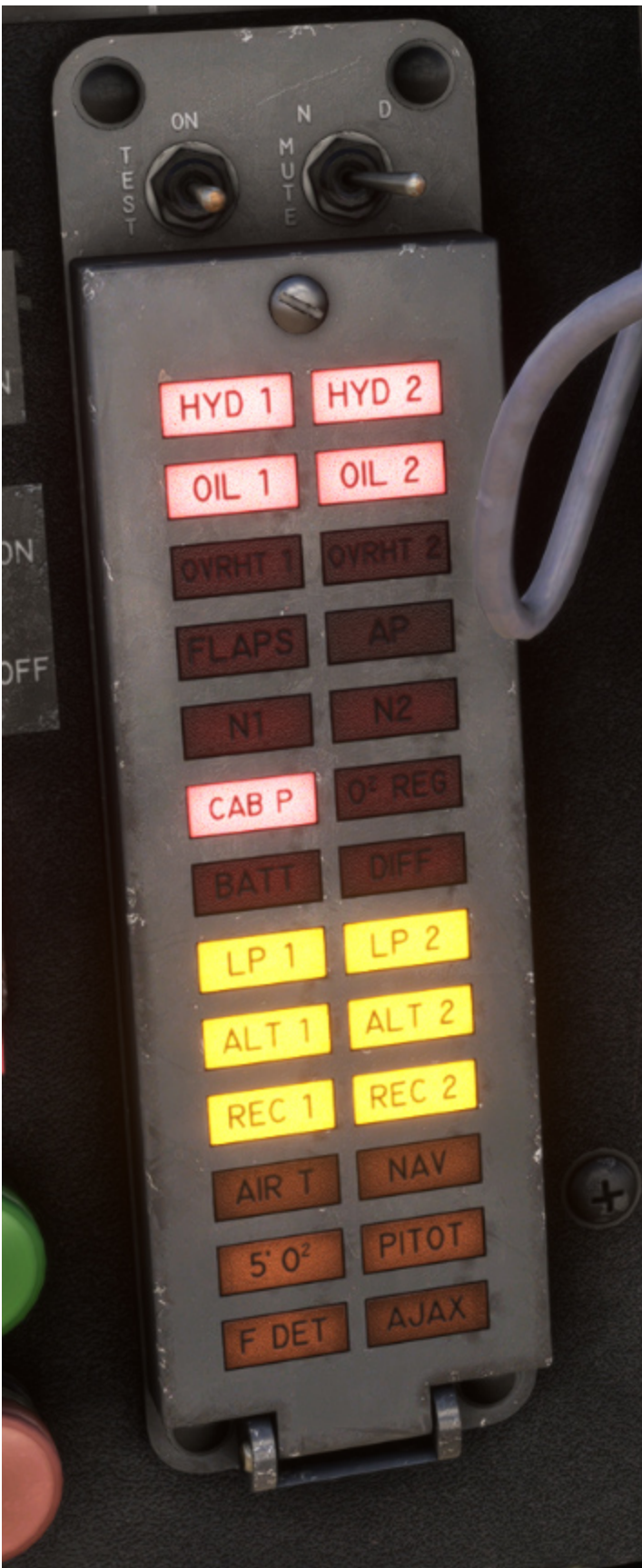

Any warning alarm will also trigger master warning alarm (blinking light and alert sound).



Two switches are located above alarms panel:

- First switch is used to toggle between three modes:
 - **TEST**: Test lights, alarms and master warning.
 - All alarms of the panel.
 - Fire indication lights.
 - Master warning light.
 - Master warning sound.
 - Landing gear lever light.
 - Fuel panel amber lights.
 - APU starter button light.
 - **ON**: Normal detection mode.
 - **MUTE**: Alarms are ignored and sound is muted, but master caution light stays on.
- Second switch has two positions (**DAY** and **NIGHT**) to toggle between two light intensities, for alarms lights but also for the other lights mentioned above.

Alarm sound switch allows to mute alarms sound and should be used only in case of anomaly with the sounds:



Here is the description of each alarm of the panel:

Alarm	Description	Alarm	Description
HYD 1	Circuit 1 hydraulic pressure below 100 bars	HYD 2	Circuit 2 hydraulic pressure below 100 bars
OIL 1	Differential oil pressure (left) below 0.84 bars	OIL 2	Differential oil pressure (right) below 0.84 bars
OVRHT 1	Left engine cooling air above 400 °C	OVRHT 2	Right engine cooling air above 400 °C
FLAPS	Flaps extended above 8° above 260 kts	AP	Autopilot failure
N1	Fuel in N1 tank below 100 kg	N2	Fuel in N2 tank below 100 kg
CAB P	Cabin pressure altitude above 27,000 ft or canopy not locked	O ² REG	Zero oxygen flow
BATT	Battery disjunction	DIFF	Elevator differential deflection failure
LP 1	Left engine fuel pressure below 2.4 bars	LP 2	Right engine fuel pressure below 2.4 bars
ALT 1	Left alternator disconnected	ALT 2	Right alternator disconnected
REC 1	Left rectifier disconnected	REC 2	Right rectifier disconnected
AIR T	Air conditioning above 80 °C	NAV	Navigation calculator failure
5' O ²	Oxygen reserve, pressure below 150 bars	PITOT	Pitot heat disabled

Alarm	Description	Alarm	Description
F DET	Fire detection failure	AJAX	AJAX failure

For HYD1 and HYD2 alarms, only a simultaneous failure will trigger master warning, as both hydraulic circuits are redundant.

Other alarms

Angle of attack alarm is heard when aircraft is flying at high AoA. It will be triggered at 15° or 20° of AoA depending on AJAX gain switch position.

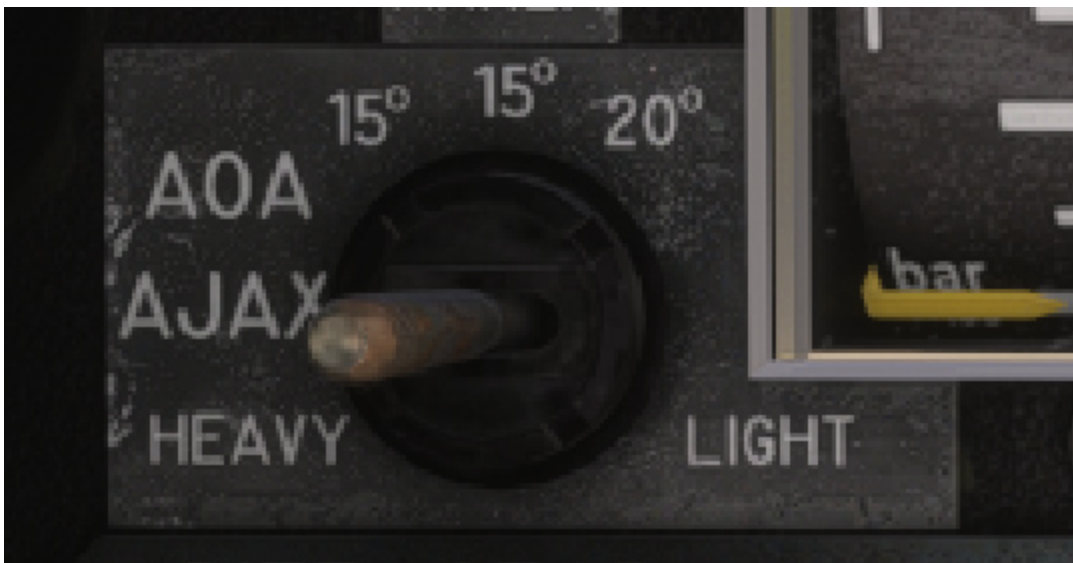

Landing gear alarm is triggered if gear is not extended with a speed below 220 kts and at least one engine below 90% RPM. A light located inside landing gear lever is blinking.



Fire alarms are triggered if a fire is detected in zone 1 or zone 2 of the engines, they are described [here](#).

Hydraulics

Description

The onboard hydraulic system powers the following components:

- Flight controls and auto-stabilization.
- Flaps and leading-edge slats.
- Airbrakes.
- Landing gear.
- Nose wheel steering and anti-shimmy system.
- Brakes.
- Refueling probe.

The system consists of two circuits, identified as circuit 1 and circuit 2. Each circuit is pressurized by a pump driven by the accessory gearbox, respectively on left and right engine.

In case of pressure loss in one of both circuits, a power transfer unit transfers hydraulic power (without fluid transfer) from the operational circuit to the failed circuit. This ensures normal operation of all hydraulic components, even in the case of a single engine loss for example.

Each circuit includes a pressurized reservoir, a cooling system using fuel as a heat exchanger, an accumulator to dampen pressure fluctuations, and a bypass valve to offload the pump during engine start or ventilation.

Hydraulic power transfer

Power transfer is managed by two switches (one per circuit), controlling by-pass valves with three operating modes:

By-pass in "OFF" Mode

- By-pass valve is closed.
- No hydraulic power is transferred.

Bypass in "AUTO" Mode

- By-pass valve of the motor-pump is controlled by a tachometric switch of the opposite generator, automatically engaging the motor-pump when an engine shuts down.

For example, if left engine is shut down:

- Generation 1 by-pass valve opens.
- The electro valve opens, supplying the motor-pump with pressure from generation 2.
- The motor-pump operates as a motor on generation 2 and as a pump on generation 1.

During engine start, with by-pass selectors in "AUTO" position, the motor-pump of the circuit corresponding to the engine being started will be functioning as soon as 42% RPM is reached, providing hydraulic power to the other circuit.

Bypass in "RESC" (EMERGENCY) Mode

- By-pass valve is always opened.
- Motor-pump permanently engaged.



To recap, here is the table of hydraulic pressures for different scenarios:

Scenario	Circuit 1 ("HYD1")	Circuit 2 ("HYD2")	Circuit 2 (electrical pump)
Normal (no flow)	206 bars	206 bars	150 bars
Warning light ON/OFF	~100 bars	~100 bars	
Circuit 1 powered by motor-pump	180 bars	206 bars	
Circuit 2 powered by motor-pump	206 bars	180 bars	

Electrical pump

A backup electric pump supplies pressure in case of failure of both engine-driven pumps. It ensures emergency operation of key systems such as flaps, airbrakes, landing gear extension, brakes, etc. The electric pump operates at 150 bars and delivers 8.5 L/min. It is controlled via a three-positions switch:

- **OFF:** pump off.
- **AUTO:** automatic activation when pressure drops below 100 bars in both circuits.
- **RESC:** pump always on.

Electro-pump is monitored through an amber light located just below the switch. The light is on if the pump is functioning.



Landing gear

The landing gear is tricycle-type, with a steerable nose wheel. The main landing gear features twin wheels, and retracts obliquely forward and stows flat under the fuselage. The auxiliary single-wheel gear retracts from front to rear.

The landing gear track width is 2.40 m, and the wheelbase is 5.70 m.

Under normal operation, landing gear actuation is electro-hydraulically controlled.

An emergency system allows for door opening and landing gear extension.



Current landing gear state is indicated in the dedicated panel:

- One green light for each gear, illuminated if gear is down and locked.
- A single red light indicating a non-locked landing gear.



Landing gear should not be extended above 250 knots to avoid any damage.

Steering

Nose wheel steering is enabled by default and requires hydraulic power to function. The nose wheel can be steered via the rudder pedals, with a maximum deflection of $\pm 55^\circ$.

A button on the left side of the yoke is used to toggle steering. You can also use the control binding **STEERING INC.**



Active steering wheel is indicated with an amber light on instruments panel:



When the aircraft is empty, with steering engaged, the minimum turning radius is 7.10 m.

Flaps and slats

High-lift system is composed of:

- Leading-edge slats (one per wing).
- Double-slotted flaps (two per wing).

Both the slats and flaps are operated by electro-hydraulic controls.

Flap control is managed via a lever on the left side console, with five selectable positions:

0° - 5° - 10° - 20° - 40°



An emergency “override” switch allows flap extension even in case of a slat deployment failure.

Flaps and slats state is indicated on the dedicated panel:

- A round amber light indicates extended flaps (at least its first position).
- Three green lights indicate current slats angle (see details [here](#)).
- A needle shows current flaps angle, from 0 to 40 degrees.



Slats operation

A cambered slat is mounted on the leading edge of each wing. Three steel rails, fixed to the slats, are guided by rollers mounted on the wing's leading edge.

The slats are driven by four screw jacks (two per slat), interconnected by torsion shafts. The entire transmission system is housed within the wing, ahead of the main wing box.

The slats have three positions (as indicated on the panel):

- Fully retracted.
- Combat position, automatic position when flying at high angle of attack.
- Fully extended, position when flaps are extended (at any position).

Slats are extended automatically below 500 knots, when angle of attack is higher than 6 degrees, and retracted when angle of attack goes below 5 degrees.

Slats can be toggled to manual mode by pressing the following button, which will be illuminated (white):



In manual mode, slats are controlled by a switch on left console (extended – neutral – retracted).



Above 500 knots, slats cannot be extended any more, and can only be retracted.

Airbrakes

The airbrakes are located on both sides of the fuselage, behind the main landing gear doors.

Each airbrake is operated by a hydraulic actuator and is locked in the retracted position by a latching mechanism.

The hydraulic pressure used is supplied by HYD 2 circuit.

The airbrakes are controlled by a toggle switch located at the end of the right engine throttle lever:



The airbrakes remain hydraulically locked in any intermediate position or at full extension. The full extension or retraction time on the ground is approximately 3 seconds.

An indicator light on instruments panel informs the pilot of their status:

- Illuminated: airbrakes unlocked.
- Off: airbrakes fully retracted and locked.

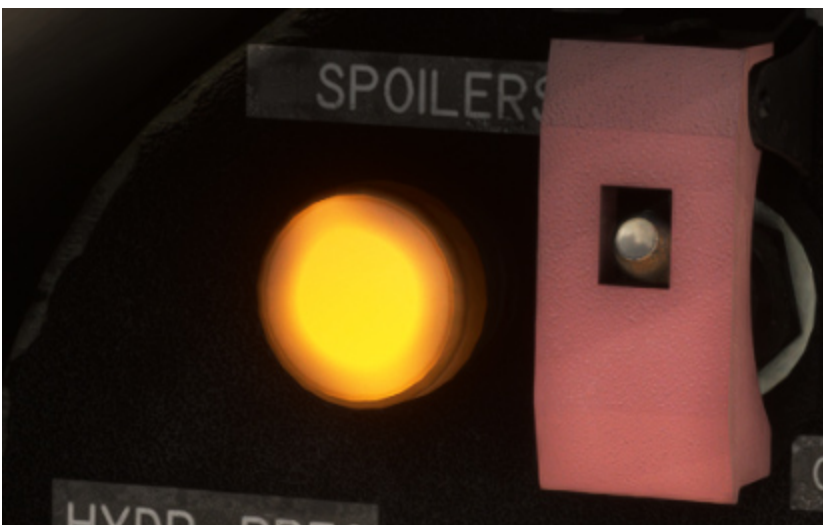

The operation of airbrakes is stopped automatically when the APU is running, as they must remain open to keep the exhaust clear.

Refueling probe

The Jaguar A can be air-to-air refueled via a retractable probe located on the right side of the fuselage, forward of the cockpit.

When retracted, the probe is housed in a recess on the fuselage side, covered by a closing door.

The probe deployment and refueling operation are controlled by the air-to-air refueling selector, with four positions:

- **EMERG**: probe extended using emergency circuit.
- **IN**: probe retracted using normal circuit.
- **OUT**: probe extended using normal circuit.
- **REFUEL**: with probe extended, position to begin refueling.

The probe's status is indicated by indicator lights located next to the selector:

- Red light illuminated when probe is moving.
- Green light illuminated when aircraft is ready for refueling.



The air-to-air refueling probe features a tip equipped with a backup self-sealing valve.

The probe assembly is mounted on a probe arm, which is attached to a swivel joint and connected to the probe actuator.



Brakes

The JAGUAR is equipped with an anti-skid system (SPAD) that maximizes the efficiency of the aircraft's mechanical braking system.

Brakes are hydraulically fed by circuit 1, and circuit 2 in case of emergency.

Normal brakes are triggered by pressing rudder pedals.

In case of emergency or to keep the aircraft parked, a handle is located in front of right console:



Flight controls

The Jaguar features:

- Two independent horizontal stabilizers.
- Two spoilers mounted ahead of the wing trailing edge.
- One vertical stabilizer.

The horizontal stabilizers serve both as elevator (simultaneous movement) and as aileron-like control surfaces (differential movement), as the aircraft does not have ailerons.

The pilot controls these surfaces via servo-actuators.

Servo control system

The aircraft's flight controls are powered by hydraulic servo actuators, which assist the pilot in maneuvering the aircraft while ensuring stability and responsiveness. The system is designed with redundancy, using the two independent hydraulic circuits to maintain control even in case of a failure.

- Elevators and rudder are controlled mechanically (directly by pilot input) and electrically (via the autopilot and stability augmentation system).
- Spoilers are controlled mechanically by the control stick but can also receive automatic inputs for roll control.

In normal operation, hydraulic pressure moves the control surfaces based on pilot input. If the system detects excessive pressure differences, it automatically adjusts to prevent abrupt movements.

When the auto-stabilization system is engaged, the flight controls receive automatic corrections to improve stability. The system ensures smooth operation by regulating hydraulic pressure based on real-time flight conditions.

Yoke

The yoke consists of a rectangular-section tube housing the aileron control linkage.

- The pilot's grip is mounted on an articulated joint for smooth operation.
- Pitch and roll trim are adjusted via a four-way switch, which automatically returns to neutral when released.
- A disengage button for auto-stabilization and autopilot is located at the base of the grip for quick manual override.



Lateral system

The roll control system transmits pilot inputs from the control stick to the servo actuators. It consists of:

- A force feedback system (AJAX) to provide consistent control effort.
- A trim system for adjusting neutral stick position.
- Ailerons for primary roll control.
- A differential deflection mechanism of horizontal stabilizer to improve roll authority at low speeds.

Force feedback (AJAX)

The AJAX system ensures that control forces remain predictable regardless of flight conditions. It automatically adjusts the resistance felt by the pilot based on airspeed and aircraft configuration.

A control switch allows the pilot to select between:

- Normal operation (**AUTO**): The system adjusts forces automatically.
- Backup mode (**RESC**): A reduced-function fallback mode.
- Reset mode (**REARM**): Used to clear system faults.



A gain selector also lets the pilot choosing between higher or lower control effort depending on preference.



Spoilers

Spoilers, mounted ahead of the trailing edge, assist roll control by disrupting airflow over the wings. They become more active as speed increases and supplement the ailerons in high-speed flight.



Differential deflection mechanism

The tailplanes can move differentially (up to $\pm 6^\circ$) to assist roll control below 425 knots.



The system operates in three modes:

- **AUTO:** Differential deflection varies with speed. Below 200 knots, the system applies $\pm 6^\circ$ of differential movement. Between 200 and 425 knots, differential deflection decreases progressively. Above 425 knots, differential deflection is disabled.
- **OFF:** Differential function is disabled, both surfaces move symmetrically.
- **MANUAL:** Pilot can manually engage maximum differential deflection ($\pm 6^\circ$) at any speed. A blue indicator light confirms its activation. The transition to full deflection takes three seconds.

Mode is selected with a yellow striped handle:



⚠ WARNING

In manual mode, speed must be limited to 200 knots.

Rudder

Rudder control is working similarly as roll control with a force feedback system (AJAX) and a trim.

Rudder surface deflection is variable:

- Higher deflection during approach to maintain control.
- Lower deflection at high speed to limit efforts applied to the control surface.

A switch allows to force low deflection (small triangle indicated) or high deflection (big triangle indicated), and is kept in AUTO position by default. In AUTO position, higher deflection is enabled when landing gear is down.



Longitudinal system

The elevator control system transmits pilot inputs from the control stick to the elevators, adjusting pitch as needed. The system includes:

- A force feedback system (AJAX) to provide consistent control effort.
- A trim system to adjust the neutral position of the yoke.
- A damping system (dash-pot) to smooth out rapid control movements.

Pitch damping

The damper helps stabilizing pitch movements by adding resistance based on the speed of control inputs. It also adjusts slightly based on airspeed. The system operates independently of the main hydraulics and includes a heating system to maintain performance.

Trim

Electrical trim allows to do adjustments on three axes (pitch, roll, yaw).

Roll and pitch trim is managed using the mushroom knob on the control stick. An indicator shows the current position of pitch trim (from -5° to 10°):



Rudder trim is managed with a switch on the left console, and a small indicator indicated:

- Left rudder trim (left arrow).
- Neutral rudder trim.
- Right rudder trim (right arrow).

Avionics

The Jaguar A had pretty basic avionics compared to later versions, which were fitted with more modern equipment like inertial navigation system.

All avionics are described in this section.

COM/NAV

V/UHF panel (called COM in our aircraft) is used for communications in VHF and UHF. It is powered with the bottom left knob on "PAL" position.

This panel is displaying active COM1 frequency which can be modified with the dials.

Other switches and preselected frequency knob (on the right) are not used in the simulation.



VOR/ILS panel is used to set NAV1 frequency, to navigate to a VOR or to fly an ILS approach.

On the left, a combined control with:

- A central dial to set the frequency in MHz.
- A ring with "A" (OFF) and "M" (ON) positions.

On the right, a combined control with:

- A central dial to set the frequency in KHz.
- A ring to test the equipment: "HG" will move **sphere indicator** deviation bars on top-left position, "BD" will move deviation bars on bottom-right position.



UHF2 panel, located on left console, is animated but does not have any usage in the simulator.



TACAN

TACAN panel is mounted on the left console, with a window displaying the active channel.

Left knob is used to set the channel tens (00 to 12, as channel goes from 0 to 126).

Right knob is a combined control with:

- A central dial to set the channel units (0 to 9).
- A ring to set current mode:
 - **OFF**: system off.
 - **REC**: reception mode.
 - **T/R**: transmission and reception (needed to get station distance).
 - **A/A**: air-to-air mode (not simulated).



Switch between X/Y modes can be done by clicking on the channel window frame, or from the EFB tablet (second tab).

Navigation indicator

Navigation indicator is based on a central rose, indicating current aircraft heading.



#	Description	#	Description
1	Operating mode selector	8	Additional vector setting knobs
2	Leeway (deviation) indicator	9	Additional vector distance
3	Single needle (VOR/GPS)	10	Additional vector bearing
4	Double needle (TACAN)	11	Normal / additional vector knob
5	VOR/LOC failure flag	12	Indicator test button

#	Description	#	Description
6	Indicator failure flag	13	Course (CRS) selection
7	TACAN distance indicator	14	Doppler panel

Mode selector has five positions:

- **VT:** VOR + TACAN.
- **OFF:** power off.
- **AU:** autonomous (emergency mode, same as VT in the simulator).
- **NA:** navigation (not simulated, same as VT in the simulator).
- **TD:** TACAN + Doppler (same as VT position, but showing deviation using Doppler calculation).

If NAV1 frequency is tuned to a VOR, single needle shows VOR station bearing. If GPS drives NAV1, the needle shows GPS target (or waypoint) direction.

If TACAN panel is powered (REC or T/R) and tuned to a detectable TACAN station, double needle will show its bearing. Station distance is displayed on the bottom (TACAN in T/R mode).

The same course setting (CRS) is used for VOR and TACAN.

Doppler panel commands Doppler radar settings. This radar is used to compute the components of the ground speed of the aircraft, and acceleration variations.

When test button is pressed with the instrument powered, double needle should do in the zone materialized by a green arc, distance should indicate 250 and the three flags should be displayed.

Additional vector

This function is used in conjunction with TACAN to set an offset and target a custom “virtual” point.

In order to enable “additional vector”, you must first ensure that the small knob on the top right of the indicator is on the correct position. Also, a valid TACAN station should be detected.

Then, you need to set the desired offset of the custom point to target (bearing and distance from the TACAN station).

The double needle will give you the bearing to this custom point.

Please note that using this function will not change the information displayed on the sphere indicator (deviation from TACAN course and TO/FROM flag).

Sphere indicator

Sphere indicator serves multiple purposes. Black hemisphere represents the earth, and the gray hemisphere symbolizes the sky. The equator represents the horizon. This sphere is slaved in heading, with roll and pitch displayed behind a fixed aircraft symbol.

Heading is read on the meridians, engraved every 10° on the sphere. Roll is represented by the tilt of the sphere, and the reading is taken from the roll scale, which is graduated every 10° . Pitch is read on the parallels of the sphere, engraved every 10° , aligned with the fixed aircraft symbol.



#	Description	#	Description
1	Attitude and heading indication	5	TO/FROM flag
2	Vertical deviation bar	6	ILS marker light and day/night setting
3	Horizontal deviation bar	7	VOR-ILS / TACAN selector
4	Normal / pole mode switch and test on press	8	Slip ball

This instrument is also used for radionavigation, depending on the position of the switch located on the bottom left:

- Vertical deviation bar (yellow) shows deviation with VOR course or TACAN course. In VOR-ILS mode, deviation with GPS course is displayed if GPS drives NAV1.
- Horizontal deviation bar (yellow) only works in VOR-ILS mode. It shows vertical ILS deviation (glideslope) or vertical deviation from the GPS if GPS drives NAV1.
- TO/FROM flag shows if the aircraft is going to, or coming from the target station.

A marker indicator light, with a lighting switch for night and day, will illuminate during an ILS approach when a marker is detected. This light can be tested by pressing normal / pole mode switch.

Heading control panel

The gyroscopic unit, the magnetic monitoring unit (MMU) and the emergency directional gyro are mounted in the nose of the aircraft. The magnetic detector is located in the vertical stabilizer.

This panel is gathering those different information to transmit the gyroscopic information and aircraft heading to the different instruments like navigation indicator and sphere indicator.

Three different magnetic indicators are signaling a failure of:

- Magnetic monitoring unit (MMU).
- Heading or vertical gyro failure in the gyroscopic unit.
- Secondary gyroscopic unit failure (used for secondary attitude indicator).



IFF/Transponder

As IFF (identification, friend or foe) does not have any usage within the simulator, this panel is simplified and only used to manage aircraft transponder, with:

- Power knob to switch between OFF, STDBY, NORM (ALT) and EMER states.
- Four code dials (top right section) to set transponder code.

The rest of the panel is animated but inoperative.



HUD

The heads-up display consists of a sighting head and an adapter box.

It features:

- A clear semi-reflective glass.
- A four-lens objective, with a 120 mm output diameter.

- A three-position function selector (approach, air-air, air-ground).
- A target elevation with adjustment drum.
- A mode selector mode (approach, air-air, air-ground).
- Two brightness setting knobs.

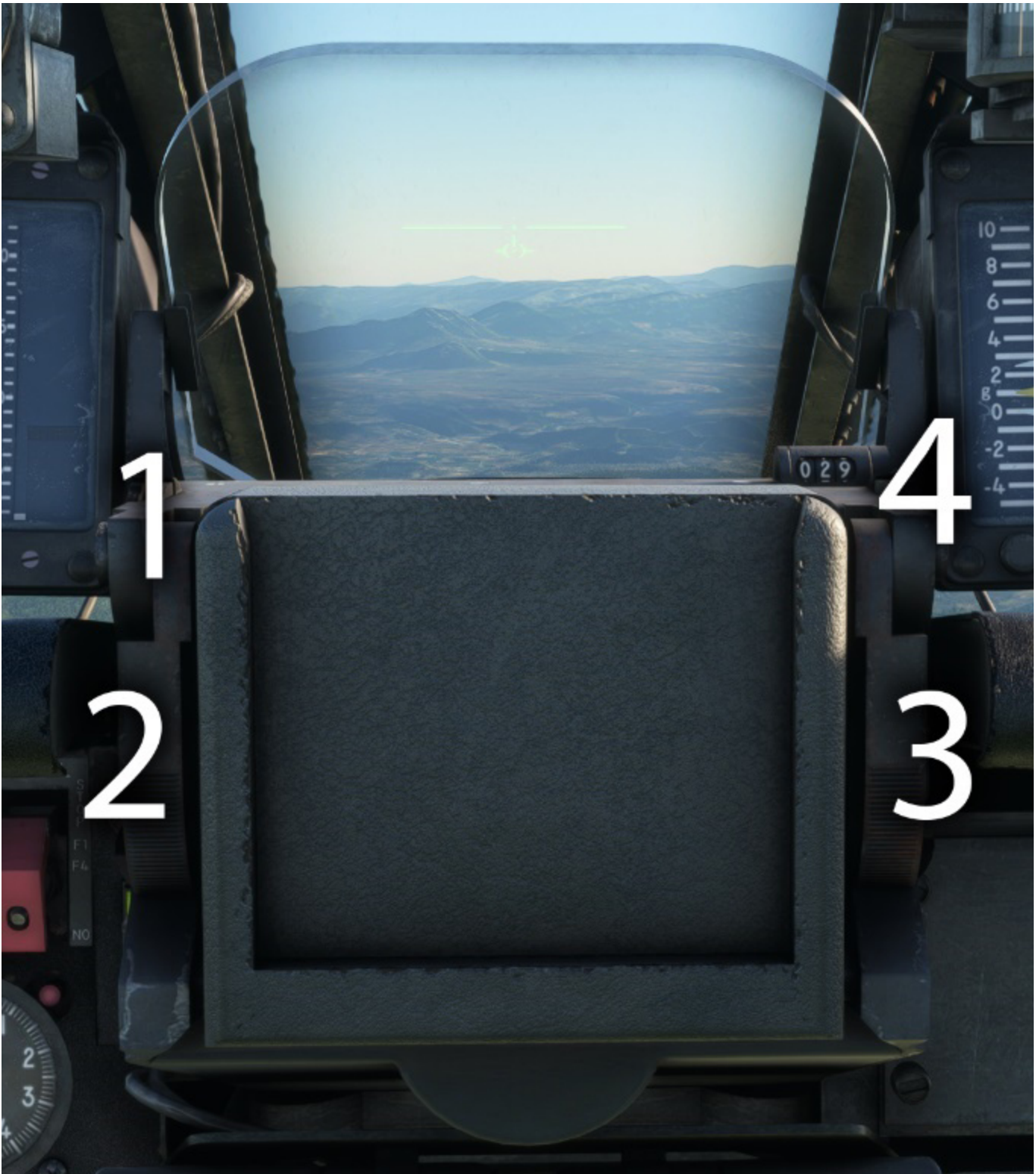

#	Description	#	Description
1	HUD mode selector	3	Fixed reticle brightness knob
2	Mobile reticle brightness knob	4	Target elevation setting

The heads-up display is powered depending on the position of armament safety knob (flight preparation, air-air preparation or armed).



In all of the three modes, the fixed reticle is the plane reference.

Approach mode

In this configuration, mobile reticle represents aircraft flight path, and is rotating to stay on the horizon line.



Air-air mode

This mode is used for air-to-air combat.

Mobile reticle is a circle made of dots with the aiming point at its center. As the G-force increases, the distance between the fixed reticle and the mobile reticle also increases.



Air-ground mode

This mode is used for air-to-ground combat.

Mobile reticle indicates striking point, based on elevation setting on the right.

On the left part, a symbol is displayed depending on radio height index (set on the instrument):

- Arrow down if aircraft is above the target height.
- Arrow up if aircraft is below the target height.
- Circle if aircraft is at the target height (+/- 50 feet).



GPS

Even though GPS was not really used in aviation when the Jaguar A was operated, we decided to add an option to use GPS units (GNS 430 or GTN 650).

The unit can be displayed on two different locations (instruments panel or right console), set from the EFB tablet.



Autopilot

The aircraft is fitted with a very basic autopilot, managed with three buttons located on the left of HUD casing.

It performs the following functions:

- In basic mode, attitude hold and heading hold (heading set at engagement).
- In advanced mode, altitude hold.



#	Description	#	Description
1	Master autopilot button (basic mode)	3	Test button
2	Altitude mode button (advanced mode)		

The pilot can engage or disengage the autopilot using the "PA" button. This button can be illuminated with two colors:

- Green when autopilot is engaged.
- Amber, blinking for three seconds, when autopilot is disengaged.

Once master button is pushed, autopilot is powered and current heading will be automatically maintained.

"ALT" button will toggle altitude hold mode, and set the target altitude to the current aircraft altitude. This button can be illuminated with two colors:

- Green when altitude hold is active.
- Red, blinking for three seconds, when altitude hold is disabled.

Test button is divided in four distinct zones:

- "L" and "R" are illuminated (amber) if roll trim is not centered.
- Red zones are illuminated to indicate pitch trim or roll trim failure.

If you wish to use vertical speed mode (V/S mode) in order to change altitude, or change current target heading, you can do it from the dedicated tab on the EFB tablet.

Radio altimeter

Mounted on the instruments panel, the indicator shows radar altitude, from 0 to 2500 feet, with a logarithmic scale from 500 feet.

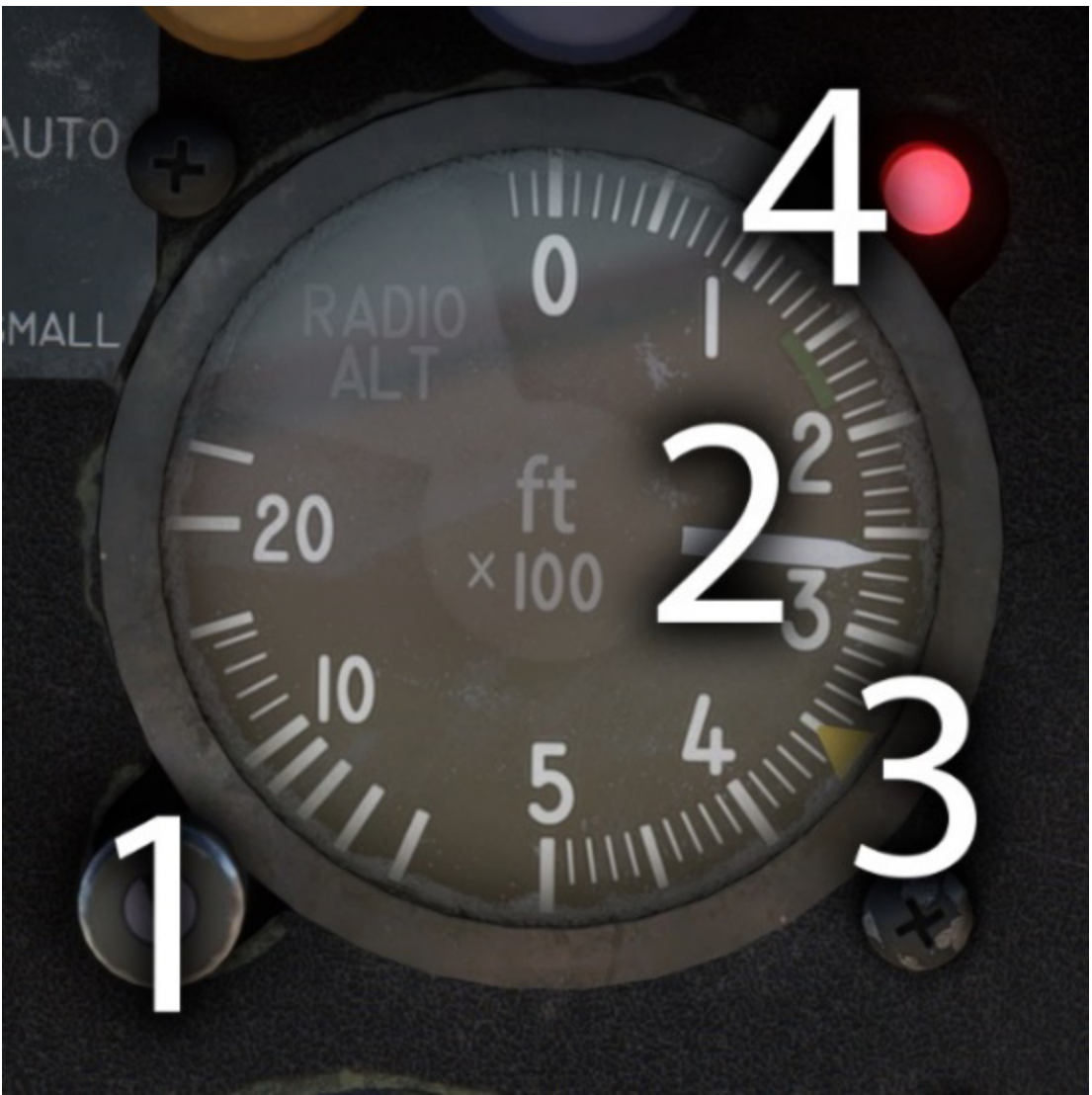

#	Description	#	Description
1	Height selection and test (on press)	3	Selected height (index)
2	Radio height needle	4	Warning light

In normal conditions, warning light is on when aircraft is losing altitude and is between 0 and 200 ft below the height set.

Control knob can be pressed (right click) in order to test the equipment: needle should go in the green sector (140 to 180 ft) and red warning light should be on.

If the aircraft has too much bank angle or pitch, the indicator will go to zero and the failure flag will appear, as the equipment cannot measure the height in those conditions.

Clock

The clock is located just above angle of attack indicator and was extensively used by pilots during navigation. It serves a dual purpose as both a clock and a chronometer.

The two larger hands indicate the current time (hours and minutes). The central second hand shows the seconds counted by the chronometer, while the small subdial at the bottom indicates the elapsed minutes.



It is controlled with a single button:

- Left click allows to set hour and minutes and will affect the time in the simulator.
- Right click allows to start and stop the chronometer. A long right click will reset the chronometer.

Electronic flight bag

The electronic flight bag is a small tablet designed for various actions.

It can be hidden by clicking on its "home" button and moved in all directions by dragging its left border.

Aircraft

First page covers main functions related to the aircraft.

Preflight equipment can be removed or displayed (if aircraft is stopped):

- Exterior covers.
- Wheel chocks.
- Pilot ladder.
- Interior sun cover.

A ground power unit (GPU) can be connected in order to power the aircraft electrically on ground without discharging the battery.

If you run out of oxygen, a button will refill it to 100%. Also, a button to repair canopy can be clicked if canopy has been jettisoned while in flight, in order to repair it.

To bypass manual actions, pre-defined configuration can be set:

- Cold & dark (all off).
- Aircraft started.
- Takeoff configuration.

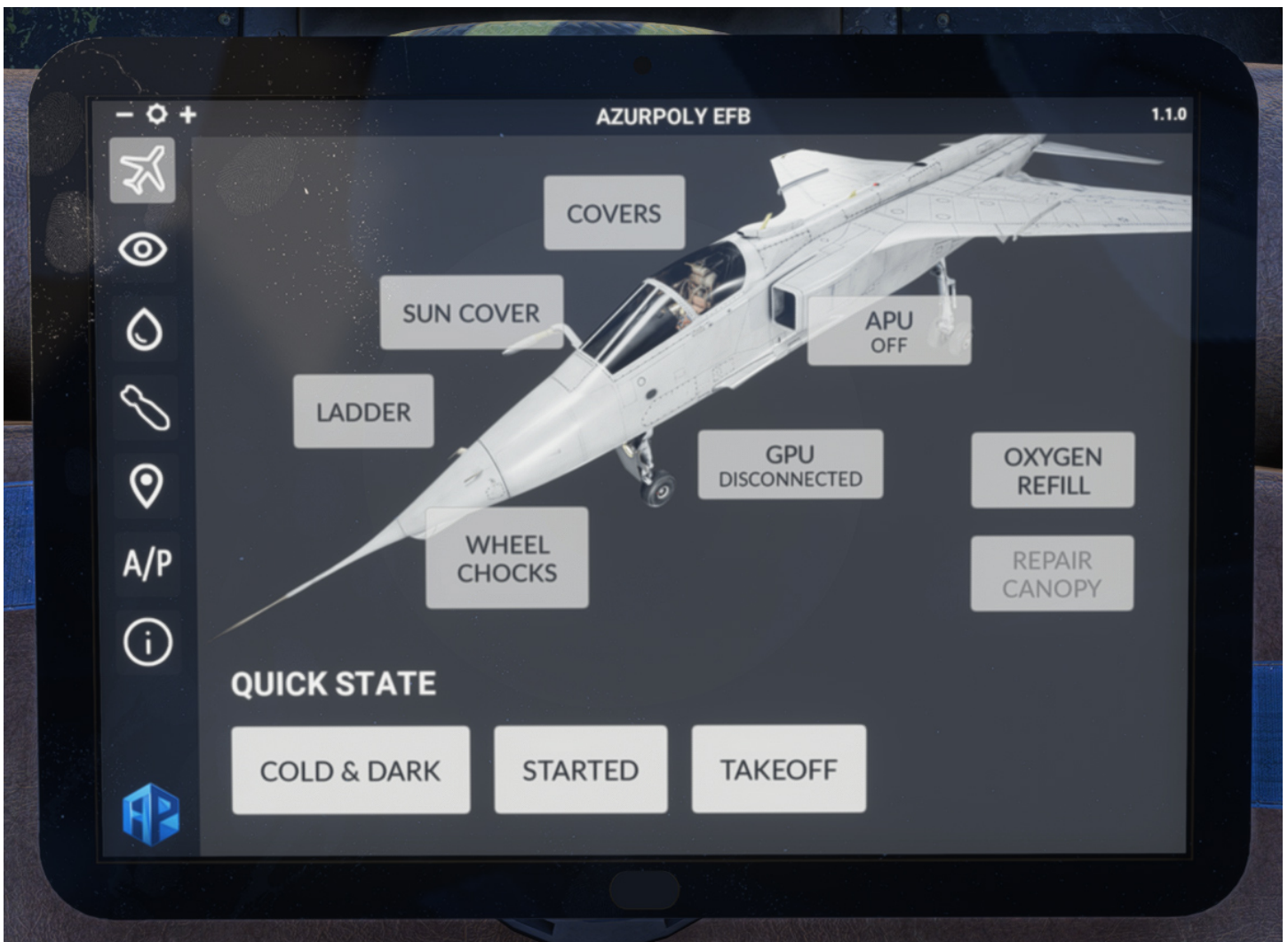

Display options

This page shows various options for the aircraft.

Few checkboxes allow to display the pilot model in interior view, and to force displaying its head as well (to do some nice screenshots in the cockpit). Please note that if yoke is hidden, pilot cannot be displayed.

You can also switch between two French helmet types (Gueneau and Gallet).

A slider can be moved to set the intensity of heat blur effect behind the aircraft.

Second column is related to GPS and radionavigation. You can display or hide three different GPS (default GNS 430, TDS SIM GTN 650 or PMS50 GTN 650), and choose its position (instruments panel or right console).

Below is a shortcut to toggle between VLOC/GPS, and another to change TACAN mode quickly (X/Y).

On the right, round buttons allow to toggle canopy, gun doors and landing gear doors.

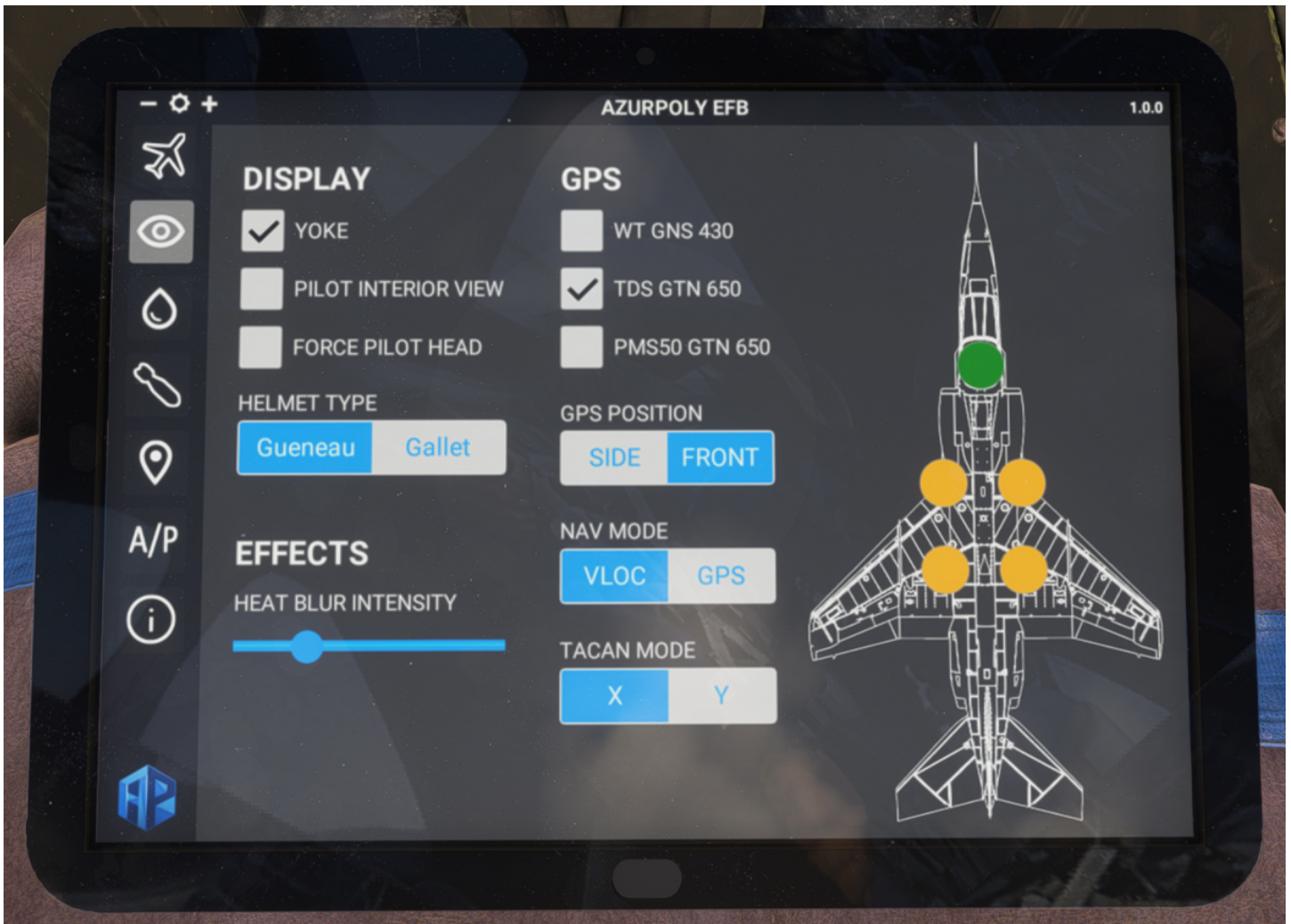

Fuel

As the Jaguar did not have a fuel quantity gauge for all tanks, you can find a recap in this page, with the quantity of fuel in each tank (including external tanks).

In order to add/remove fuel in a tank, click on it and move the slider as desired. You can also add or remove each of the external tanks.

On the bottom left, a recap displays total fuel weight, payload weight and total weight of the aircraft, with maximum takeoff weight which should not be exceeded.

Lastly, a TOTALIZER button can be used to set the totalizer value automatically in the cockpit, using the current fuel weight in the aircraft, as moving the drum manually can be a bit annoying.

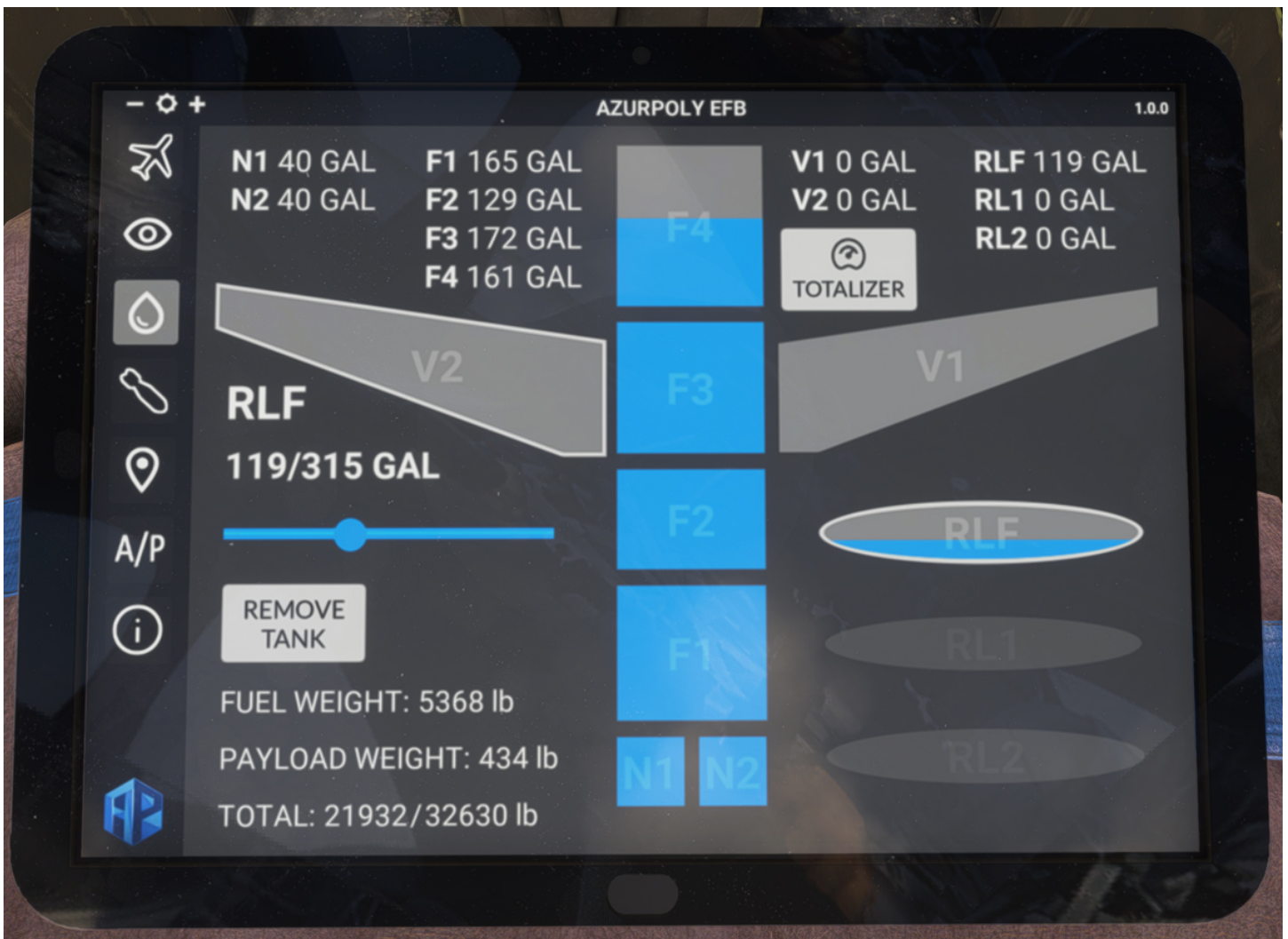

Weapons

This page is used to display or hide external ordnance (distinct weapons for A and GR1 variants).

You can also add or remove external tanks easily from this page.

The impact of each object is simulated on the weight and balance of the aircraft. Each object will also increase drag, with a notable effect on performance (see [performance section](#)).



Map

This menu consists of a map showing current aircraft position.

Different controls on the right part allow to interact with the map:

- Zoom buttons.
- Button to stop auto centering to aircraft position.
- Trajectory button to show or hide aircraft path.



Autopilot

In addition to the autopilot fitted to the Jaguar, you can use the EFB for an easier operation.

Clicking on top AUTOPILOT button allows to switch autopilot master on.

When turning ALT or HDG mode on, current altitude/heading will be set as target, and you can change the values with \oplus and \ominus buttons, in order to change target altitude or heading.

VS button allows to initiate a climb or a descent by choosing a target vertical speed (feet/min). The aircraft will automatically stop at the target altitude (set below ALT button) and hold it.



Info

This menu indicates version of the aircraft currently installed on your machine. A message will be displayed if an update is available.

You can also see your total time spent inside the Jaguar.



FLIGHT TIME: 91h 48min



VERSION INFORMATION:



CURRENTLY INSTALLED: 1.0.0



LATEST AVAILABLE: 1.0.0

YOU HAVE THE LATEST VERSION



PLEASE DOWNLOAD THE MANUAL ON AZURPOLY.COM

A/P



Procedures

Reference speeds

Please note that aircraft weight has a big impact on some reference speeds like stall speed, this table is for indicative purposes only.

Stall speed (flaps down)	100 kts
Stall speed (flaps up)	130 kts
Rotation speed	170 kts
Initial climb speed	300 kts
Approach speed	150 kts
Maximum speed with flaps extended	220 kts
Maximum speed with gear extended	250 kts

Checklists

We propose in this section detailed checklists, close to the ones used during real aircraft operation.

In addition to this manual, you can find in-game checklists, with essential steps, dynamic validation and cameras management to help you complete each step.

BEFORE START	
Covers	REMOVED
Chocks	REMOVED
Control Locks	REMOVED
Master Battery	ON
Pressurization Lever	OFF
Air Conditioning	OFF

BEFORE START	
Voltmeter	CHECKED
Alarms	TESTED
Fuel Totalizer	SET
Fuel Gauge	TESTED
Fuel Quantity	CHECKED
Flaps & Gear Lights	TESTED
Differential Deflection	AUTO
Beacon Lights	BOTH

STARTING	
Hydraulic Electro Pump	AUTO
Spoilers	EXTENDED
Hydraulic Electro Pump	OFF
Fuel Low Pressure Valves	OPENED
Fuel Feed Pumps	ON
APU Start Switch	RUN
APU Starter	PUSHED
APU Bleed Air	START
Right engine	
Starter	ON
Throttle	IDLE
Wait for RPM 50%	
HYD2 Pressure	180 BARS
Alternator (Right)	ON
Rectifier (Left)	ON

STARTING	
Rectifier (Right)	ON
Left Engine	
Starter	ON
Throttle	IDLE
Wait for RPM 50%	
HYD1 Pressure	180 BARS
Alternator (Left)	ON
APU Start Switch	STOP
APU Bleed Air	VENTILATION

BEFORE TAXI	
Canopy	CLOSED
Canopy	LOCKED
Pressurization Lever	ON
Air Conditioning	ON
Secondary Attitude Indicator	ON
F3/F4 Fuel Pumps	AUTO
Slats	AUTO
Hydraulic Electro Pump	AUTO
VOR/ILS Power	ON
TACAN Power	RECEIVE
IFF	STANDBY
Spoilers	RETRACTED
Parking Brake	OFF
Taxi Light	ON

BEFORE TAXI	
Brakes	TESTED

BEFORE TAKEOFF	
Flaps	20 DEGREES
Pitot Heat	ON
IFF	NORM
Trim	SET
Air Conditioning	OFF
Landing Light	ON
Flight Controls	CHECKED

CLIMB	
Landing Gear	UP
Flaps	UP
Air Conditioning	ON

BEFORE LANDING	
Landing Gear	DOWN
Flaps	DOWN
Landing Light	ON

AFTER LANDING	
Flaps	UP
IFF	STANDBY

AFTER LANDING	
Taxi Light	ON

PARKING	
Pitot Heat	OFF
VOR/ILS Power	OFF
TACAN Power	OFF
IFF	OFF
Spoilers	EXTENDED
Pressurization Lever	OFF
Air Conditioning	OFF
Secondary Attitude Indicator	OFF
Hydraulic Electro Pump	OFF
Throttle (Both)	CUTOFF
Fuel Feed Pumps	OFF
Fuel Low Pressure Valves	CLOSED
Taxi Light	OFF
Beacon Lights	OFF
Alternator (Both)	OFF
Rectifier (Both)	OFF
Master Battery	OFF
Parking Brake	ON
Chocks	INSTALLED
Covers	INSTALLED

Performance

Performance charts are valid for Adour Mk.102 engines, which equipped the Jaguar A and early Jaguar GR1 versions. British Jaguar was later upgraded to Mk.104 engines, around 10% more powerful.

Performance charts are presented with various “drag indexes”. This index represents the effect of the carriage of external stores on performance. Each store has a numerical drag index value proportional to its drag coefficient, the total drag index value for a particular configuration being the sum of the individual values.

Please note that each drag index value represents the installed drag of store including its suspension equipment (pylon).

Item	Drag index
Clean aircraft	5
Empty pylon	2
1,200 litre external tank	11
Magic missile	5
AS37 missile	10
1,000 lb bomb	8
2 x 1,000 lb bomb (in tandem)	13
BL755 cluster bomb	9

Takeoff

Takeoff is executed with 20° flaps for all configurations, and employ maximum reheat (afterburner) power.

At the defined rotation speed (VR), the stick is moved quickly and smoothly aft to rotate the aircraft to the appropriate climb-out incidence.

Once clear of the runway, the landing gear is retracted and the climb-out incidence is maintained until clear of obstacles when the incidence may be reduced to permit the aircraft to accelerate more rapidly.

Flap is selected up at a safe speed depending on aircraft mass.

TYRE LIMITED MAXIMUM TAKE-OFF MASS USING NORMAL TECHNIQUE

JAGUAR GR.MK.1 T.MK.2
 DATA: ESTIMATED
 FUEL: AVTUR / FS11

ENGINES: ADOUR MK.102/JPI03
 DATE OF ISSUE: AL 4 MARCH 1977

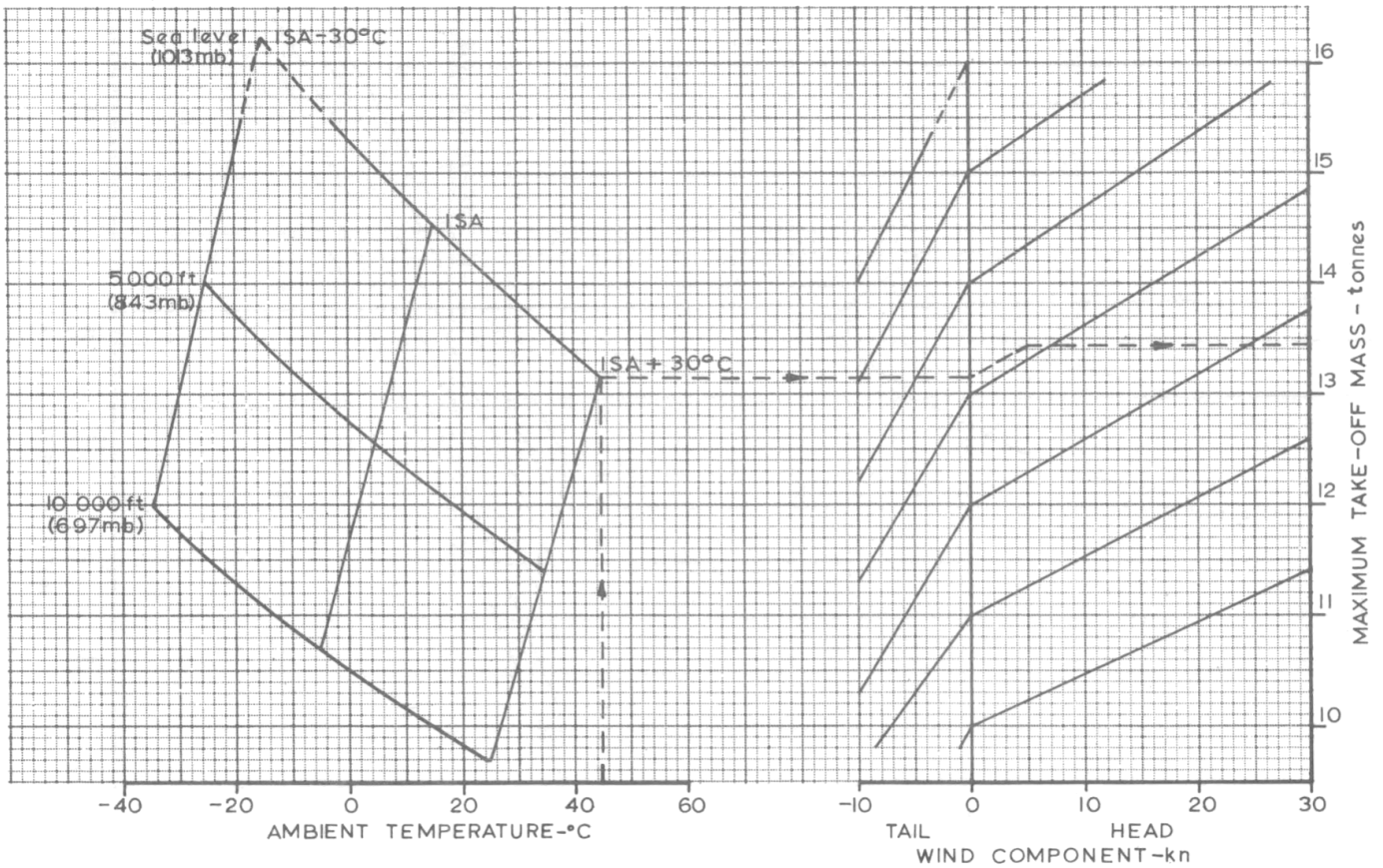

ROTATION SPEED NORMAL TAKE-OFF TECHNIQUE

JAGUAR GR MK.1 T.MK.2.
 DATA: ESTIMATED
 FUEL: AVTUR / FSII

ENGINES: ADOUR MK.102 / JP103
 DATE OF ISSUE: AL 4 MARCH 1977

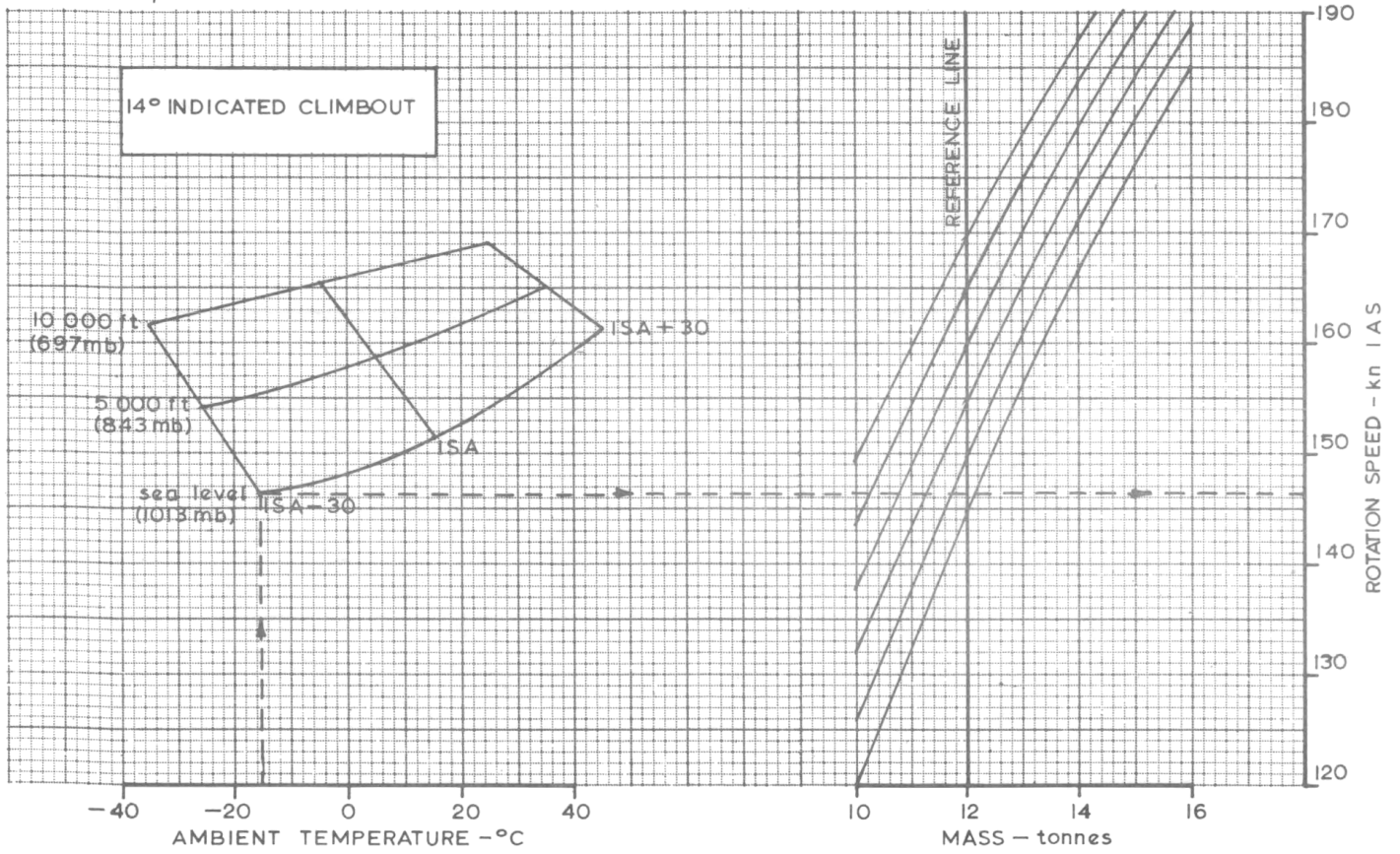

NORMAL TAKE - OFF GROUND RUN

JAGUAR GR. MK.1 T. MK. 2
 DATA: ESTIMATED
 FUEL: AVTUR / FSII

ENGINES: ADOUR MK. 102 / JP.103
 DATE OF ISSUE: AL.4 MARCH 1977

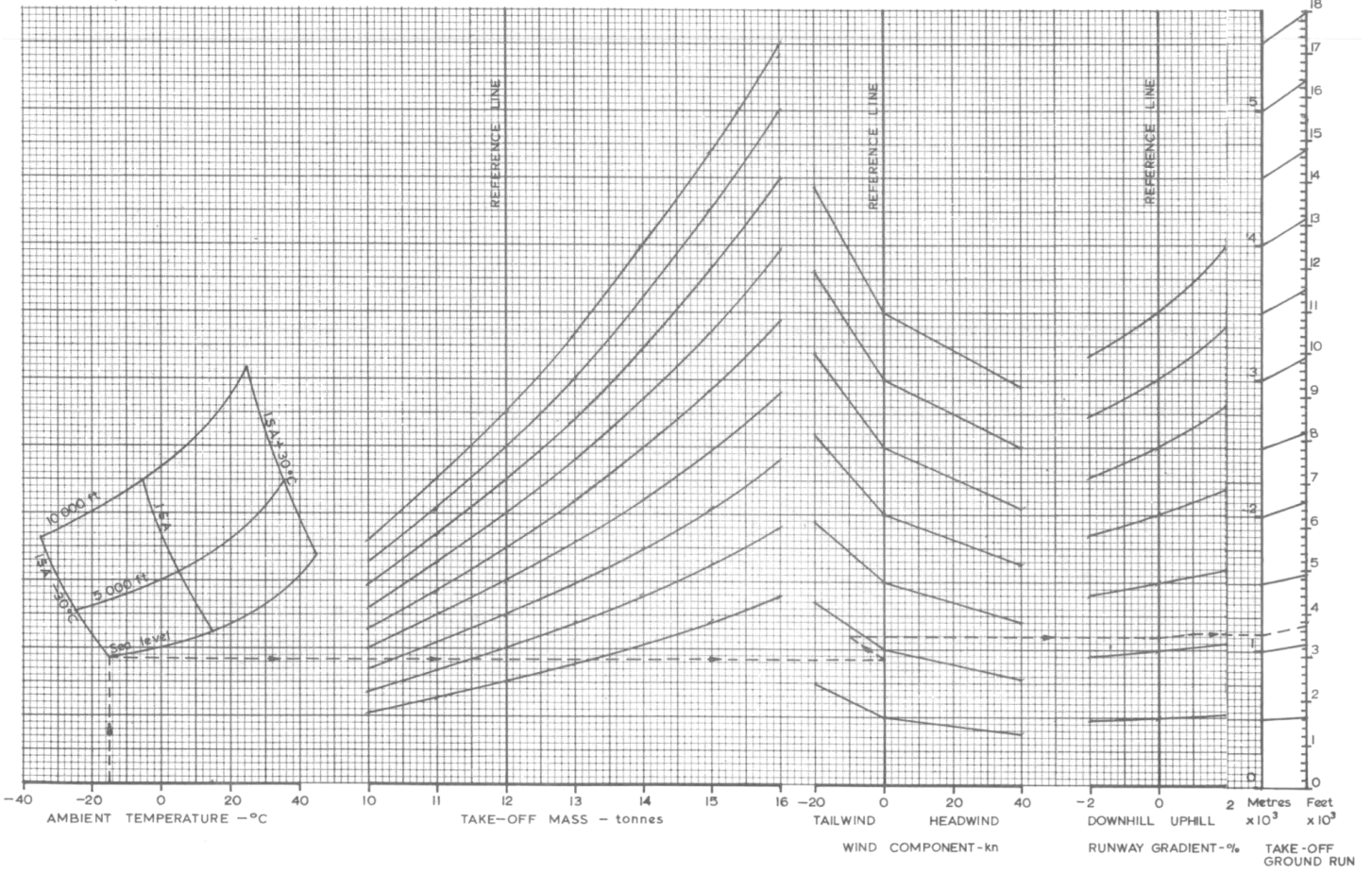

NORMAL TAKE-OFF DISTANCE TO 50 ft

JAGUAR GR MK.1. T.MK.2
 DATA: ESTIMATED
 FUEL: AVTUR / FSII

ENGINES: ADOUR MK. 102/JP 103
 DATE OF ISSUE: AL 4 MARCH 1977

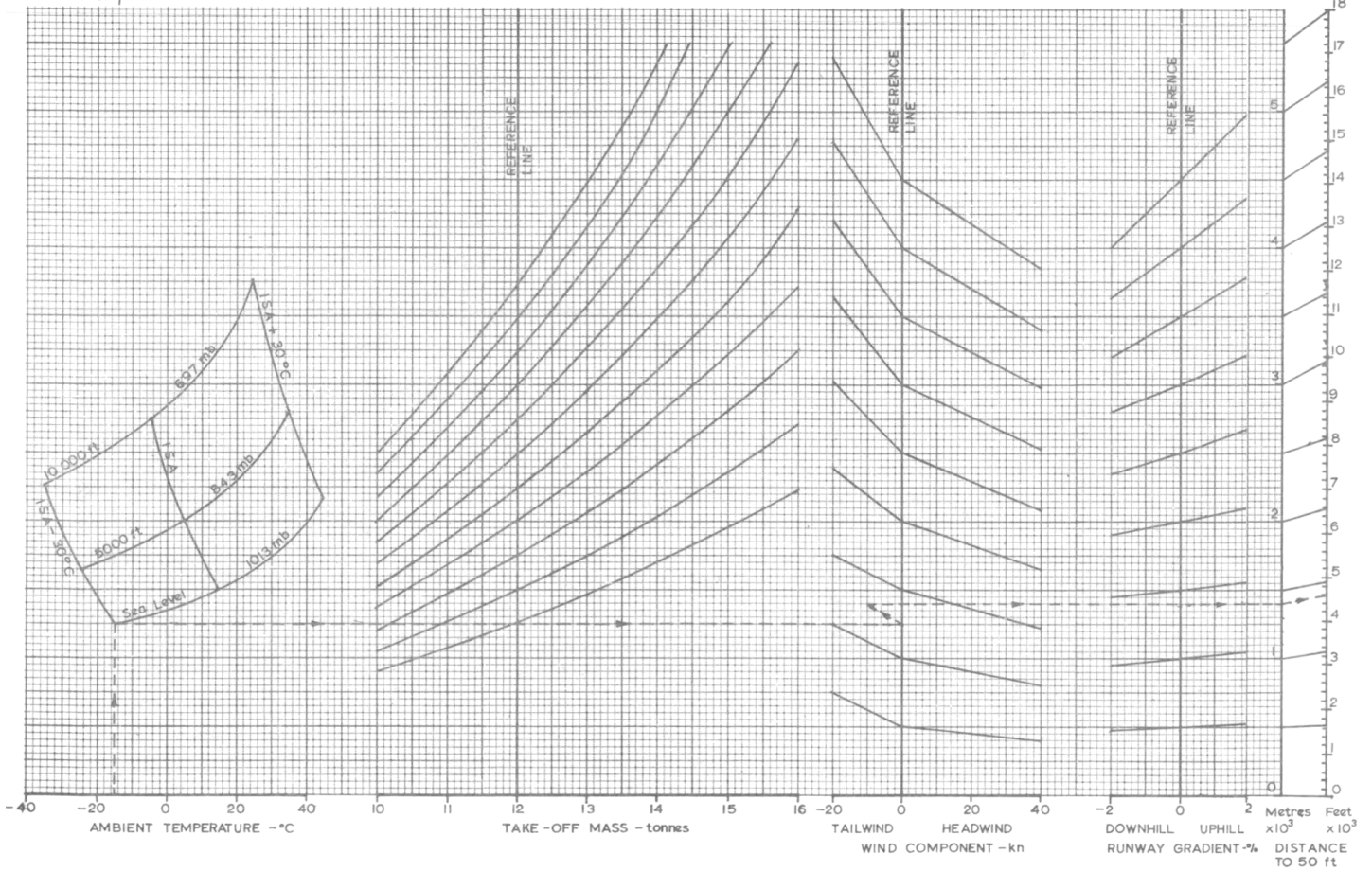

Climb

Climb performance charts are presented for various drag indexes, in I.S.A. conditions (+15°C at sea level, pressure 1013.2 millibars).

First chart shows fuel used and time for takeoff and acceleration to max dry climb (where drag index has a negligible effect).

Other charts show, for each drag index, a first chart to calculate time and distance to reach a desired altitude, and a second chart to calculate the fuel needed.

PRE-MAX. DRY CLIMB — FUEL AND TIME

JAGUAR GR.MK.1 T.MK.2
 DATA: ESTIMATED/FLIGHT TEST
 FUEL: AVTUR/FSII

ENGINES: ADOUR MK.102/JP103
 DATE OF ISSUE: MAY 1975

NOTE:

1. THIS CHART SHOWS FUEL USED AND TIME FOR TAKE-OFF AND ACCELERATION TO MAX. DRY CLIMB SPEED WITH REHEAT SHUT DOWN AT 350 kt.
2. DRAG INDEX HAS A NEGLIGIBLE EFFECT.

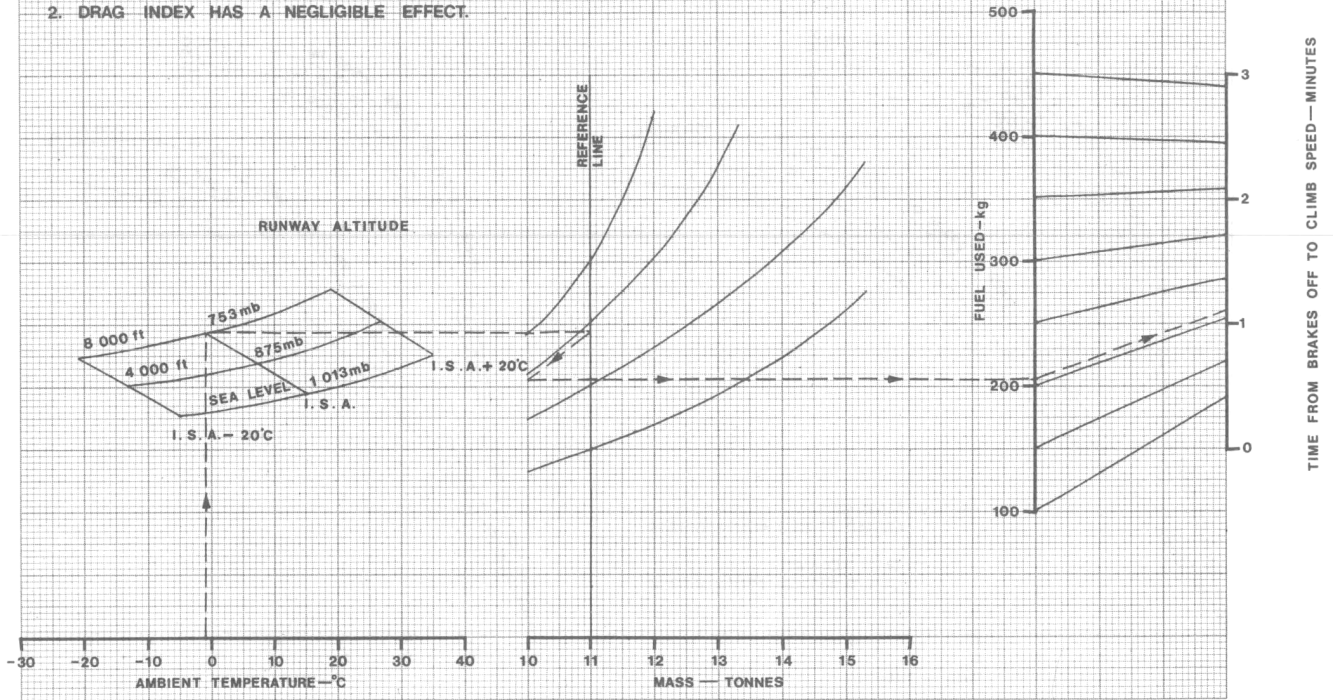

CLIMB PERFORMANCE — DRAG INDEX 0, I.S.A.

JAGUAR GR.MK.1 T.MK.2
 DATA: ESTIMATED/FLIGHT TEST
 FUEL: AVTUR/FSII

ENGINES: ADOUR MK.102/JP103
 DATE OF ISSUE: MAY 1975

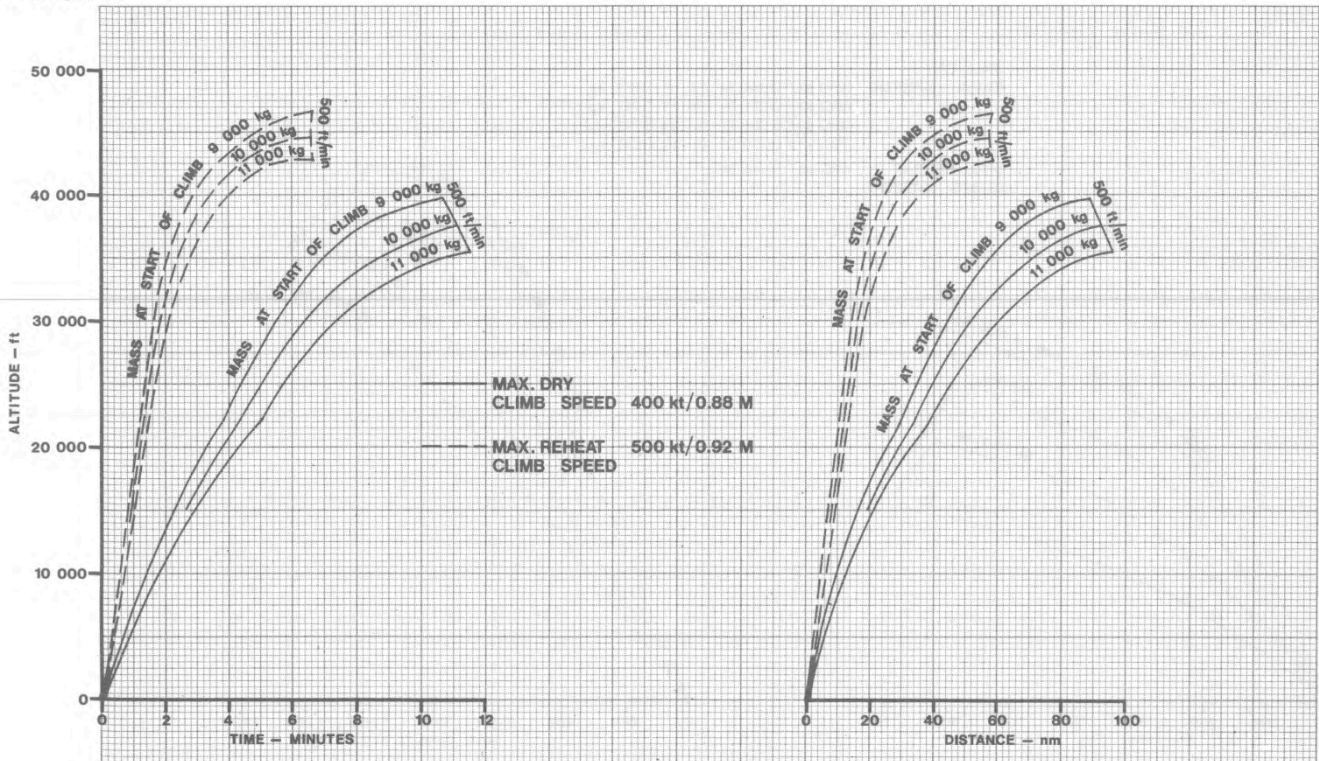

CLIMB PERFORMANCE - DRAG INDEX 0, I.S.A.

JAGUAR GR.MK.1 T.MK.2
 DATA: ESTIMATED/FLIGHT TEST
 FUEL: AVTUR/FSII

ENGINES: ADOUR MK.102/JP103
 DATE OF ISSUE: MAY 1975

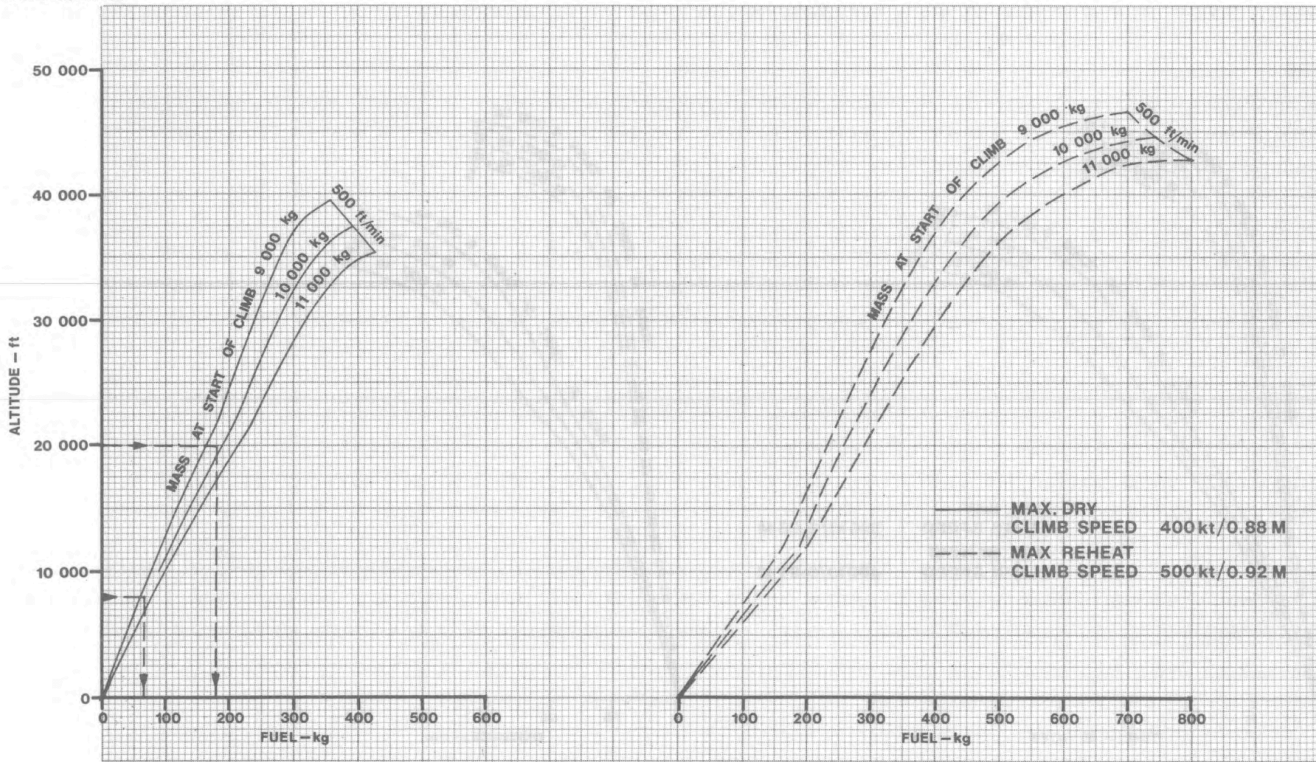

CLIMB PERFORMANCE - DRAG INDEX 20, I.S.A.

JAGUAR GR.MK.1 T.MK.2
 DATA: ESTIMATED/FLIGHT TEST
 FUEL: AVTUR/FSII

ENGINES: ADOUR MK.102/JP103
 DATE OF ISSUE: MAY 1975

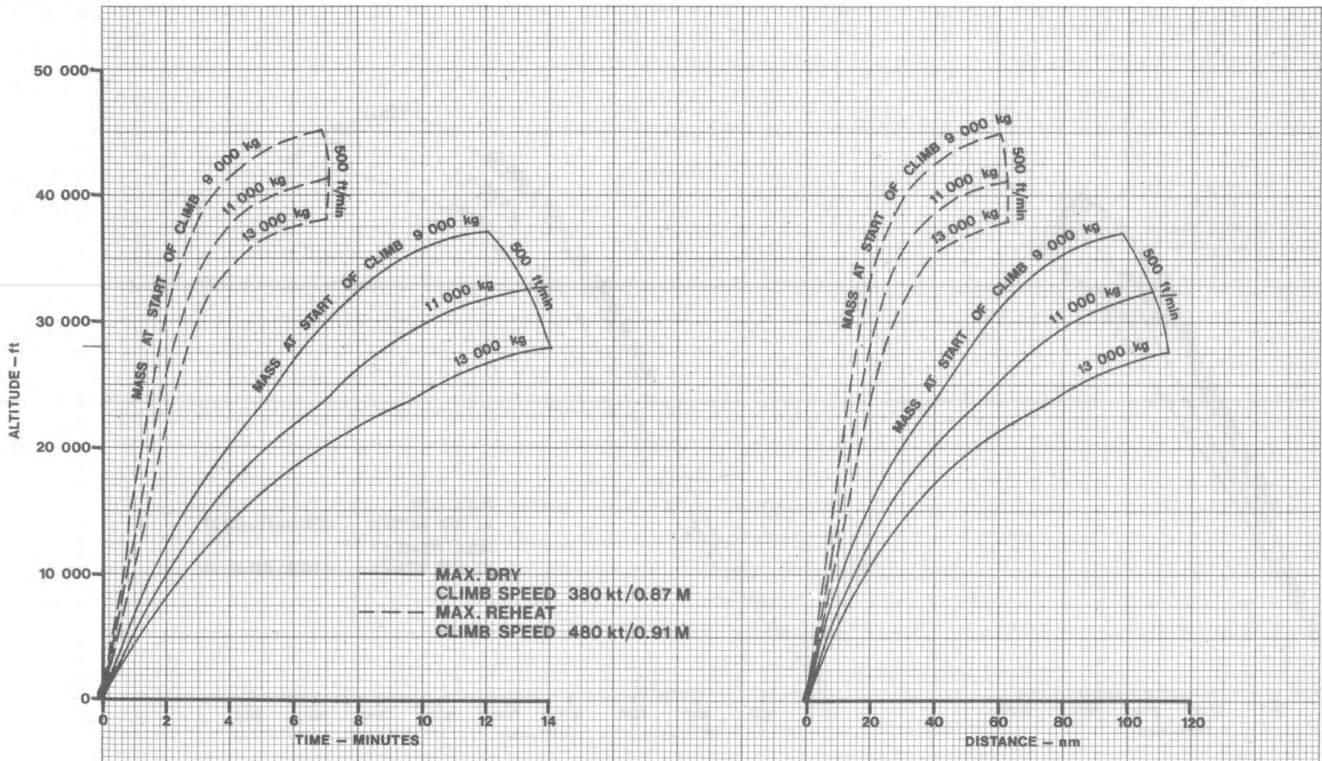

CLIMB PERFORMANCE – DRAG INDEX 20, I.S.A.

JAGUAR GR.MK.1 T.MK.2
 DATA: ESTIMATED/FLIGHT TEST
 FUEL: AVTUR/FSII

ENGINES: ADOUR MK.102/JP103
 DATE OF ISSUE: MAY 1975

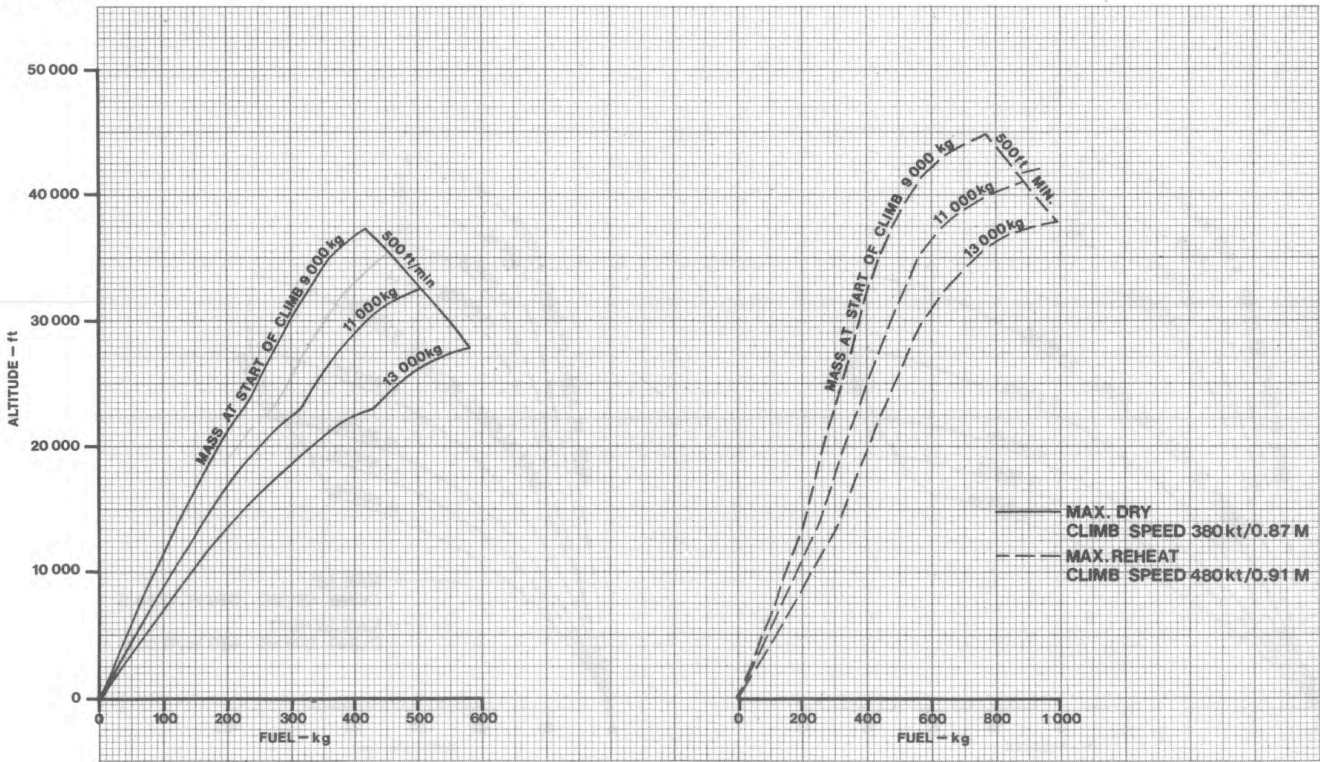

CLIMB PERFORMANCE – DRAG INDEX 40, I.S.A.

JAGUAR GR.MK.1 T.MK.2
 DATA: ESTIMATED/FLIGHT TEST
 FUEL: AVTUR/FSII

ENGINES: ADOUR MK.102/JP103
 DATE OF ISSUE: MAY 1975

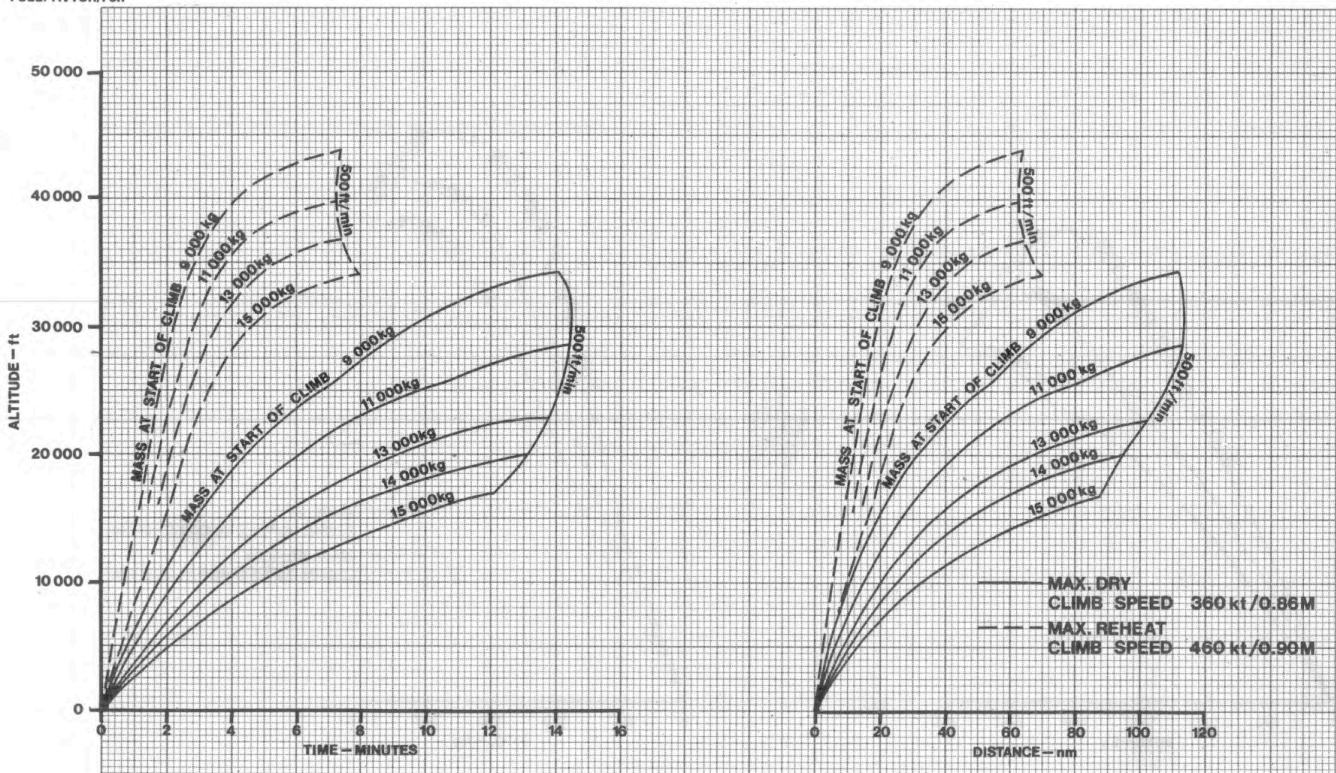

CLIMB PERFORMANCE – DRAG INDEX 40, I.S.A.

JAGUAR GR.MK.1 T.MK.2
 DATA: ESTIMATED/FLIGHT TEST
 FUEL: AVTUR/FSII

ENGINES: ADOUR MK.102/JP103
 DATE OF ISSUE: MAY 1975

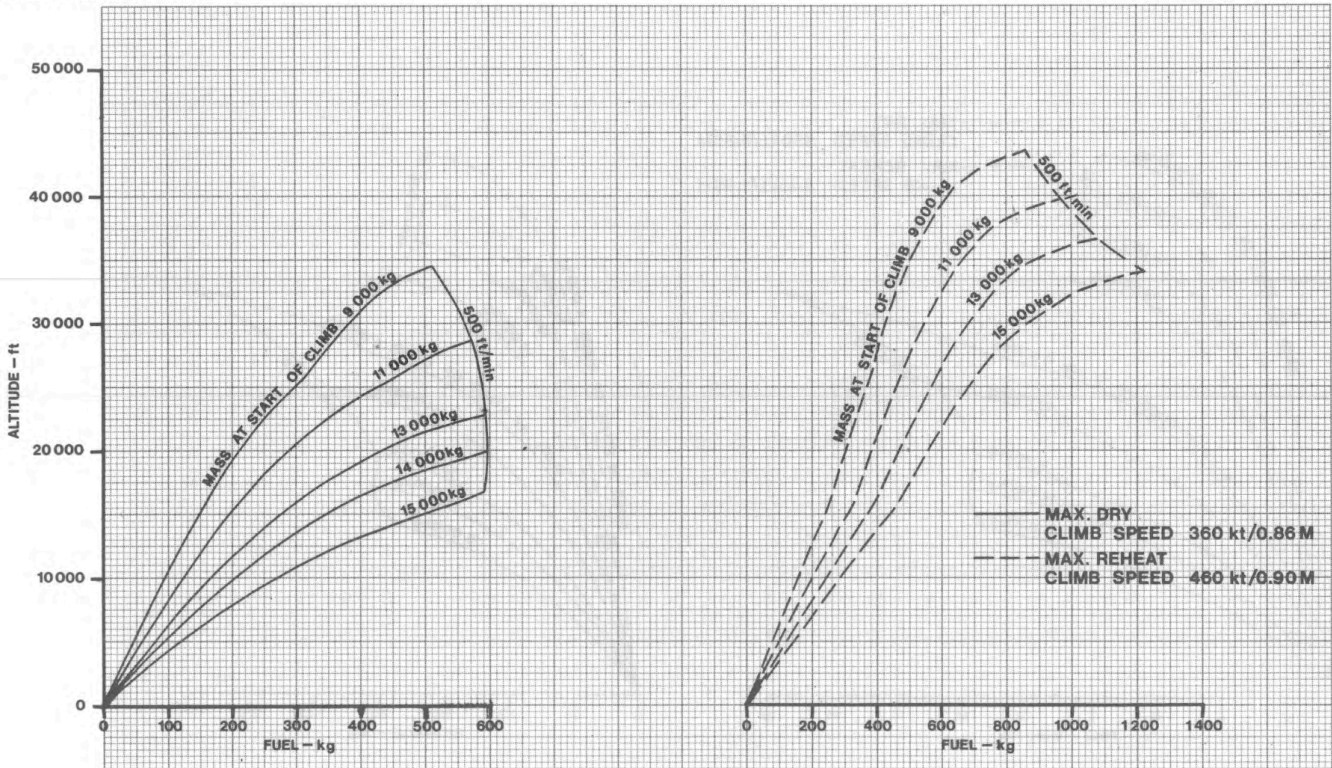

CLIMB PERFORMANCE – DRAG INDEX 60, I.S.A.

JAGUAR GR.MK.1 T.MK.2
 DATA: ESTIMATED/FLIGHT TEST
 FUEL: AVTUR/FSII

ENGINES: ADOUR MK.102/JP103
 DATE OF ISSUE: MAY 1975

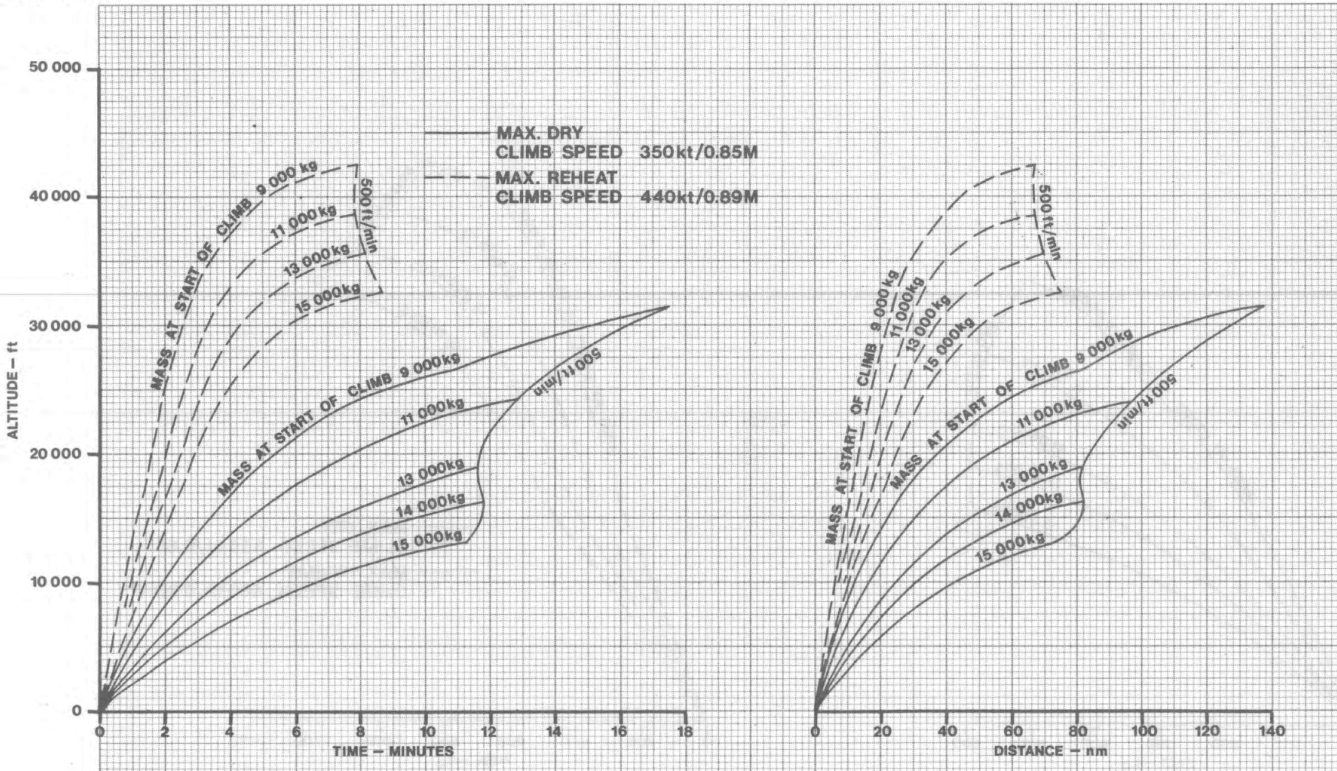

CLIMB PERFORMANCE – DRAG INDEX 60, I.S.A.

JAGUAR GR.MK.1 T.MK.2
 DATA: ESTIMATED/FLIGHT TEST
 FUEL: AVTUR/FSH

ENGINES: ADOUR MK.102/JP103
 DATE OF ISSUE: MAY 1975

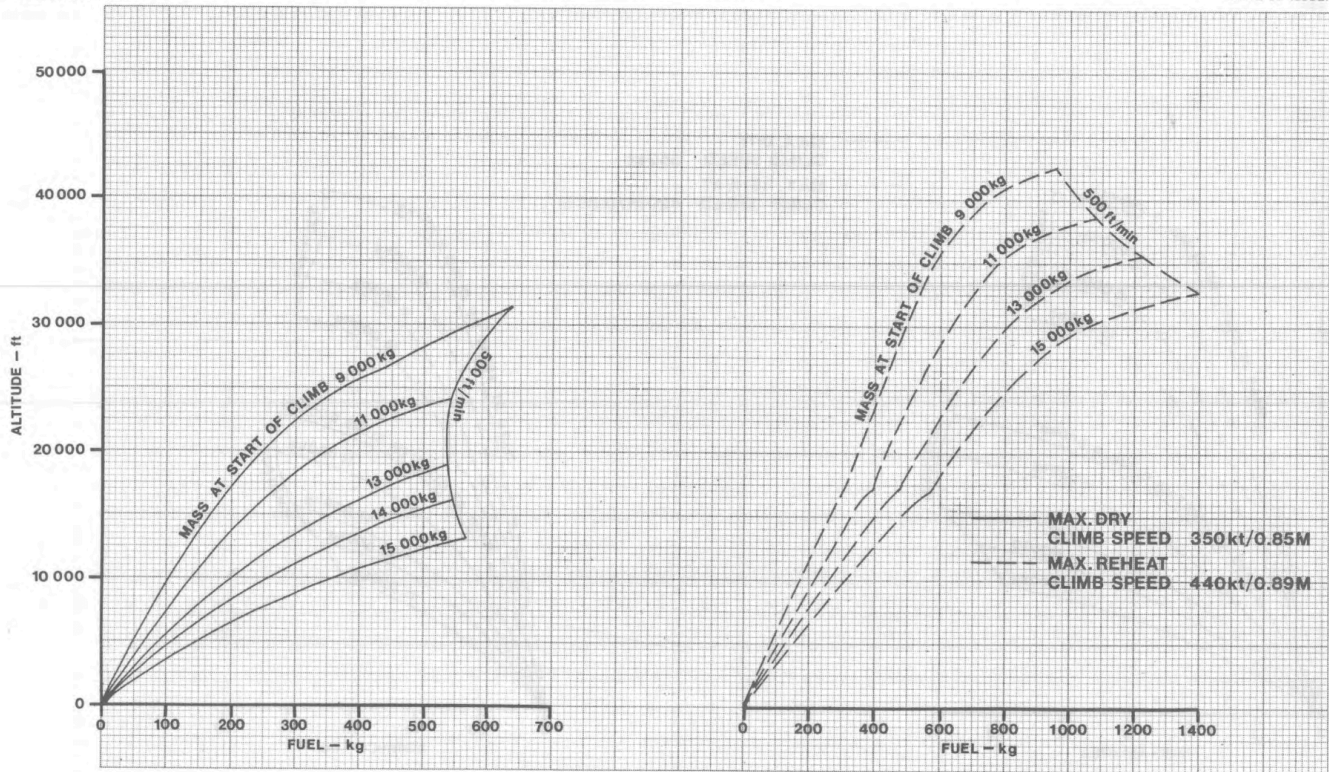

Cruise

Cruise performance is presented in tabular forms.

Each table shows, for a range of Mach numbers and altitude at constant mass and drag index values, the fuel consumption, the distance travelled per 100 kg of fuel used, and the percentage HP compressor speed (% RPM).

At each altitude, the Mach number giving maximum endurance is shown in red and that giving maximum range, in green.

LEVEL CRUISE, TWO ENGINES OPERATING – MASS 8 000 kg, DRAG INDEX 0

JAGUAR GR.MK.1 T.MK.2
 DATA: ESTIMATED/FLIGHT TEST
 FUEL: AVTUR/FSI

ENGINES: ADOUR MK.102/P103
 DATE OF ISSUE: MAY 1975

ALTITUDE		MACH NUMBER									POWER SETTING		
		0.50	0.55	0.60	0.65	0.70	0.75	0.80	0.85	0.90	MAX. CONT.	MAX. DRY	
SEA LEVEL	FUEL FLOW – kg/min	21.6	24.1	27.0	30.2	34.0	38.0	42.9	48.2	57.7	FUEL FLOW – kg/min	55.7	64.9
	FUEL USED – kg/Anm	3.9	4.0	4.1	4.2	4.4	4.6	4.9	5.1	5.8	FUEL USED – kg/Anm	5.7	6.4
	DISTANCE – Anm/100kg	25.5	25.1	24.5	23.7	22.7	21.7	20.6	19.4	17.2	DISTANCE – Anm/100kg	17.6	15.6
	ENG. SPEED – %RPM	85.7	86.9	88.6	90.1	91.6	93.3	94.7	96.5	98.7	MACH NUMBER	0.89	0.92
5 000 ft	FUEL FLOW – kg/min	18.9	20.8	23.0	25.6	28.6	31.9	35.8	40.1	47.8	FUEL FLOW – kg/min	53.3	60.4
	FUEL USED – kg/Anm	3.5	3.5	3.5	3.6	3.8	3.9	4.1	4.4	4.9	FUEL USED – kg/Anm	5.4	5.9
	DISTANCE – Anm/100kg	28.6	28.6	28.2	27.5	26.6	25.5	24.2	23.0	20.4	DISTANCE – Anm/100kg	18.7	16.8
	ENG. SPEED – %RPM	85.2	86.4	87.6	89.4	90.6	91.8	93.5	95.1	97.4	MACH NUMBER	0.92	0.94
10 000 ft	FUEL FLOW – kg/min	16.9	18.2	19.9	21.8	24.1	26.7	29.9	33.3	39.5	FUEL FLOW – kg/min	48.5	57.5
	FUEL USED – kg/Anm	3.2	3.1	3.1	3.2	3.2	3.3	3.5	3.7	4.1	FUEL USED – kg/Anm	4.9	5.6
	DISTANCE – Anm/100kg	31.5	32.2	32.1	31.7	30.9	29.9	28.5	27.1	24.2	DISTANCE – Anm/100kg	20.6	17.8
	ENG. SPEED – %RPM	84.4	85.8	87.0	88.2	89.4	90.6	92.3	93.6	96.2	MACH NUMBER	0.94	0.97
15 000 ft	FUEL FLOW – kg/min	16.4	16.2	17.4	18.8	20.5	22.5	25.0	27.7	32.7	FUEL FLOW – kg/min	44.3	54.1
	FUEL USED – kg/Anm	3.1	2.8	2.8	2.5	2.8	2.9	3.0	3.1	3.5	FUEL USED – kg/Anm	4.5	5.3
	DISTANCE – Anm/100kg	31.8	35.4	36.0	40.3	35.6	34.8	33.4	32.0	28.7	DISTANCE – Anm/100kg	22.4	18.7
	ENG. SPEED – %RPM	85.3	85.3	86.5	87.8	88.3	89.9	91.1	92.4	94.8	MACH NUMBER	0.95	0.97
20 000 ft	FUEL FLOW – kg/min	17.4	16.0	15.6	16.5	17.8	19.2	21.1	23.2	27.0	FUEL FLOW – kg/min	39.0	43.3
	FUEL USED – kg/Anm	3.4	2.8	2.5	2.5	2.5	2.5	2.6	2.7	2.9	FUEL USED – kg/Anm	4.0	4.4
	DISTANCE – Anm/100kg	29.5	35.2	39.5	40.3	40.3	40.0	38.9	37.5	34.1	DISTANCE – Anm/100kg	25.2	22.9
	ENG. SPEED – %RPM	88.0	86.6	86.0	86.6	87.8	89.0	89.9	91.2	93.2	MACH NUMBER	0.96	0.97
25 000 ft	FUEL FLOW – kg/min	19.1	16.9	15.6	14.7	15.4	16.4	17.7	19.3	22.3	FUEL FLOW – kg/min	36.3	37.1
	FUEL USED – kg/Anm	3.8	3.1	2.6	2.3	2.2	2.2	2.2	2.3	2.5	FUEL USED – kg/Anm	3.7	3.8
	DISTANCE – Anm/100kg	26.3	32.7	38.6	44.2	45.6	45.9	45.3	44.2	40.5	DISTANCE – Anm/100kg	26.8	26.5
	ENG. SPEED – %RPM	91.2	88.6	87.3	86.6	87.2	87.8	88.8	90.0	92.2	MACH NUMBER	0.97	0.98
30 000 ft	FUEL FLOW – kg/min		20.3	17.3	15.7	14.8	14.5	15.4	16.4	18.7	FUEL FLOW – kg/min	23.6	31.6
	FUEL USED – kg/Anm		3.8	2.9	2.5	2.2	2.0	2.0	2.0	2.1	FUEL USED – kg/Anm	2.5	3.3
	DISTANCE – Anm/100kg		26.6	34.0	40.7	46.5	50.6	51.0	50.8	47.2	DISTANCE – Anm/100kg	39.3	30.5
	ENG. SPEED – %RPM		94.4	91.4	89.4	87.9	87.2	88.4	89.0	91.1	MACH NUMBER	0.97	0.98
36 090 ft	FUEL FLOW – kg/min					19.2	16.3	14.8	14.4	15.8	FUEL FLOW – kg/min	23.6	25.9
	FUEL USED – kg/Anm					2.9	2.3	1.9	1.8	1.8	FUEL USED – kg/Anm	2.5	2.8
	DISTANCE – Anm/100kg					34.8	44.1	51.7	56.5	54.5	DISTANCE – Anm/100kg	39.3	36.1
	ENG. SPEED – %RPM					95.8	92.0	90.0	89.2	90.3	MACH NUMBER	0.97	0.98
40 000 ft	FUEL FLOW – kg/min							17.4	16.1	16.1	FUEL FLOW – kg/min	20.0	21.2
	FUEL USED – kg/Anm							2.3	2.0	1.9	FUEL USED – kg/Anm	2.2	2.3
	DISTANCE – Anm/100kg							43.9	50.5	53.6	DISTANCE – Anm/100kg	45.3	43.3
	ENG. SPEED – %RPM							96.6	94.0	94.0	MACH NUMBER	0.95	0.96

LEVEL CRUISE, TWO ENGINES OPERATING – MASS 10 000kg , DRAG INDEX 0

JAGUAR GR MK 1 T.MK 2
 DATA: ESTIMATED FLIGHT TEST
 FUEL: AVTUR FSH

ENGINES: ADOUR MK.102 JP103
 DATE OF ISSUE: MAY 1975

ALTITUDE		MACH NUMBER										POWER SETTING	
		0.50	0.55	0.60	0.65	0.70	0.75	0.80	0.85	0.90	MAX. CONT.	MAX. DRY	
SEA LEVEL	FUEL FLOW – kg/min	23.3	25.5	28.2	31.3	34.9	38.8	43.6	48.9	58.3	FUEL FLOW – kg/min	56.0	63.2
	FUEL USED – kg/Anm	4.2	4.2	4.3	4.4	4.5	4.7	4.9	5.2	5.9	FUEL USED – kg/Anm	5.7	6.2
	DISTANCE – Anm/100kg	23.7	23.7	23.4	22.9	22.1	21.3	20.2	19.2	17.0	DISTANCE – Anm/100kg	17.5	16.1
	ENG. SPEED – %RPM	86.3	88.1	89.3	90.5	92.1	93.4	95.1	96.5	99.1	MACH NUMBER	0.89	0.92
5 000 ft	FUEL FLOW – kg/min	20.9	22.5	24.4	26.8	29.7	32.8	36.7	40.9	48.6	FUEL FLOW – kg/min	52.7	62.0
	FUEL USED – kg/Anm	3.9	3.8	3.8	3.8	3.9	4.0	4.2	4.4	5.0	FUEL USED – kg/Anm	5.3	6.1
	DISTANCE – Anm/100kg	25.9	26.5	26.6	26.3	25.6	24.7	23.6	22.5	20.1	DISTANCE – Anm/100kg	18.9	16.4
	ENG. SPEED – %RPM	86.4	87.7	88.8	89.8	91.0	92.2	93.8	95.4	97.8	MACH NUMBER	0.92	0.94
10 000 ft	FUEL FLOW – kg/min	20.8	20.1	21.5	23.2	25.4	27.9	30.9	34.3	40.4	FUEL FLOW – kg/min	49.7	55.6
	FUEL USED – kg/Anm	3.9	3.4	3.4	3.4	3.4	3.5	3.6	3.8	4.2	FUEL USED – kg/Anm	5.0	5.5
	DISTANCE – Anm/100kg	25.6	29.1	29.7	29.8	29.3	28.6	27.5	26.4	23.7	DISTANCE – Anm/100kg	20.1	18.2
	ENG. SPEED – %RPM	87.7	87.0	88.2	89.4	90.3	91.5	92.7	94.2	96.5	MACH NUMBER	0.94	0.95
15 000 ft	FUEL FLOW – kg/min	22.0	20.2	19.4	20.5	22.0	23.9	26.2	28.8	33.7	FUEL FLOW – kg/min	43.5	50.2
	FUEL USED – kg/Anm	4.2	3.5	3.1	3.0	3.0	3.1	3.1	3.3	3.6	FUEL USED – kg/Anm	4.5	5.0
	DISTANCE – Anm/100kg	23.7	28.4	32.3	33.1	33.1	32.7	31.8	30.8	27.8	DISTANCE – Anm/100kg	22.5	19.9
	ENG. SPEED – %RPM	90.1	88.4	87.7	88.9	89.5	90.7	91.6	92.8	95.3	MACH NUMBER	0.94	0.96
20 000 ft	FUEL FLOW – kg/min	24.8	21.9	19.9	18.9	19.6	20.9	22.6	24.5	28.3	FUEL FLOW – kg/min	38.4	44.5
	FUEL USED – kg/Anm	4.8	3.9	3.2	2.8	2.7	2.7	2.8	2.8	3.1	FUEL USED – kg/Anm	4.0	4.5
	DISTANCE – Anm/100kg	20.6	25.8	30.8	35.3	36.6	36.8	36.3	35.4	32.5	DISTANCE – Anm/100kg	25.3	22.3
	ENG. SPEED – %RPM	93.4	91.3	89.8	88.5	89.0	89.9	90.8	92.1	94.0	MACH NUMBER	0.95	0.97
25 000 ft	FUEL FLOW – kg/min		25.5	22.1	20.0	18.7	18.3	19.5	21.0	23.8	FUEL FLOW – kg/min	33.8	37.8
	FUEL USED – kg/Anm		4.6	3.7	3.1	2.7	2.4	2.4	2.5	2.6	FUEL USED – kg/Anm	3.5	3.9
	DISTANCE – Anm/100kg		21.6	27.2	32.7	37.6	41.0	41.1	40.7	37.9	DISTANCE – Anm/100kg	28.5	25.7
	ENG. SPEED – %RPM		96.5	93.2	91.3	90.2	89.6	91.0	91.4	93.1	MACH NUMBER	0.96	0.97
30 000 ft	FUEL FLOW – kg/min				24.0	21.1	19.4	18.5	18.6	20.7	FUEL FLOW – kg/min	28.8	32.0
	FUEL USED – kg/Anm				3.8	3.1	2.6	2.4	2.2	2.3	FUEL USED – kg/Anm	3.1	3.4
	DISTANCE – Anm/100kg				26.6	32.6	37.9	42.5	44.9	42.7	DISTANCE – Anm/100kg	32.8	29.8
	ENG. SPEED – %RPM				97.6	94.5	92.6	91.3	91.2	92.6	MACH NUMBER	0.96	0.97
36 090 ft	FUEL FLOW – kg/min								20.4	20.2	FUEL FLOW – kg/min	24.0	25.5
	FUEL USED – kg/Anm								2.5	2.3	FUEL USED – kg/Anm	2.6	2.8
	DISTANCE – Anm/100kg								39.9	42.6	DISTANCE – Anm/100kg	37.8	36.0
	ENG. SPEED – %RPM								95.9	96.0	MACH NUMBER	0.95	0.96
40 000 ft	FUEL FLOW – kg/min										FUEL FLOW – kg/min		
	FUEL USED – kg/Anm										FUEL USED – kg/Anm		
	DISTANCE – Anm/100kg										DISTANCE – Anm/100kg		
	ENG. SPEED – %RPM										MACH NUMBER		

LEVEL CRUISE, TWO ENGINES OPERATING – MASS 8 500kg, DRAG INDEX 20

APIOIB-3100-16

JAGUAR GR.MK.1 T.MK.2
DATA: ESTIMATED/ FLIGHT TEST
FUEL: AVTUR/FSII

ENGINES: ADOUR MK.102 JP103
DATE OF ISSUE: MAY 1975

ALTITUDE		MACH NUMBER									POWER SETTING		
		0.50	0.55	0.60	0.65	0.70	0.75	0.80	0.85	0.90	MAX. CONT.	MAX. DRY	
SEA LEVEL	FUEL FLOW – kg/min	24.6	27.6	31.1	35.1	39.7	44.9	51.1	58.3		FUEL FLOW – kg/min	55.4	61.8
	FUEL USED – kg/Anm	4.5	4.6	4.7	4.9	5.1	5.4	5.8	6.2		FUEL USED – kg/Anm	6.1	6.4
	DISTANCE – Anm/100kg	22.4	22.0	21.2	20.4	19.5	18.4	17.2	16.1		DISTANCE – Anm/100kg	16.5	15.5
	ENG. SPEED – %RPM	87.4	89.4	90.6	92.2	94.0	95.5	97.3	99.2		MACH NUMBER	0.83	0.87
5 000 ft	FUEL FLOW – kg/min	21.5	23.7	26.5	29.6	33.3	37.5	42.5	48.5	59.2	FUEL FLOW – kg/min	50.4	59.2
	FUEL USED – kg/Anm	4.0	4.0	4.1	4.2	4.4	4.6	4.9	5.3	6.1	FUEL USED – kg/Anm	5.4	6.1
	DISTANCE – Anm/100kg	25.2	25.1	24.5	23.7	22.8	21.6	20.4	19.0	16.5	DISTANCE – Anm/100kg	18.5	16.5
	ENG. SPEED – %RPM	87.0	88.2	89.9	91.2	92.9	94.5	96.2	97.9	101.1	MACH NUMBER	0.86	0.90
10 000 ft	FUEL FLOW – kg/min	19.9	20.7	22.7	25.2	28.0	31.4	35.4	40.1	49.0	FUEL FLOW – kg/min	47.1	56.5
	FUEL USED – kg/Anm	3.7	3.5	3.6	3.6	3.8	3.9	4.2	4.4	5.1	FUEL USED – kg/Anm	5.0	5.8
	DISTANCE – Anm/100kg	26.8	28.3	28.1	27.5	26.6	25.4	24.0	22.6	19.5	DISTANCE – Anm/100kg	20.1	17.3
	ENG. SPEED – %RPM	87.0	87.6	88.6	90.3	91.6	93.3	94.8	96.5	99.6	MACH NUMBER	0.89	0.92
15 000 ft	FUEL FLOW – kg/min	19.9	19.3	19.8	21.6	23.8	26.4	29.5	33.3	40.5	FUEL FLOW – kg/min	42.8	49.1
	FUEL USED – kg/Anm	3.7	3.4	3.2	3.2	3.3	3.4	3.5	3.7	4.3	FUEL USED – kg/Anm	4.5	5.1
	DISTANCE – Anm/100kg	26.8	29.8	31.6	31.4	30.7	29.7	28.3	26.7	23.2	DISTANCE – Anm/100kg	22.2	19.8
	ENG. SPEED – %RPM	87.0	87.8	88.4	89.6	90.8	92.0	93.8	95.1	98.0	MACH NUMBER	0.91	0.93
20 000 ft	FUEL FLOW – kg/min	20.8	19.4	18.8	18.9	20.4	22.4	24.8	27.7	33.3	FUEL FLOW – kg/min	38.2	45.7
	FUEL USED – kg/Anm	4.1	3.4	3.1	2.8	2.9	2.9	3.0	3.2	3.6	FUEL USED – kg/Anm	4.1	4.7
	DISTANCE – Anm/100kg	24.6	29.0	32.6	35.2	35.0	34.2	33.0	31.4	27.7	DISTANCE – Anm/100kg	24.7	21.1
	ENG. SPEED – %RPM	90.4	89.2	88.5	88.5	90.1	90.9	92.6	94.1	96.9	MACH NUMBER	0.92	0.94
25 000 ft	FUEL FLOW – kg/min	23.4	20.7	19.1	18.3	18.1	19.1	20.9	23.0	27.4	FUEL FLOW – kg/min	33.7	37.9
	FUEL USED – kg/Anm	4.7	3.8	3.2	2.8	2.6	2.5	2.6	2.7	3.0	FUEL USED – kg/Anm	3.6	4.0
	DISTANCE – Anm/100kg	21.4	26.6	31.5	35.7	38.8	39.5	38.5	37.0	33.0	DISTANCE – Anm/100kg	27.7	24.8
	ENG. SPEED – %RPM	95.1	92.2	91.0	89.8	89.7	90.1	91.5	92.8	95.5	MACH NUMBER	0.93	0.94
30 000 ft	FUEL FLOW – kg/min			21.9	19.9	18.7	18.2	18.3	19.7	22.9	FUEL FLOW – kg/min	29.0	31.3
	FUEL USED – kg/Anm			3.7	3.1	2.7	2.5	2.3	2.4	2.6	FUEL USED – kg/Anm	3.2	3.4
	DISTANCE – Anm/100kg			26.8	32.1	36.8	40.4	42.8	42.3	38.6	DISTANCE – Anm/100kg	31.5	29.4
	ENG. SPEED – %RPM			95.7	93.6	92.2	91.4	91.4	92.2	94.6	MACH NUMBER	0.93	0.94
36 090 ft	FUEL FLOW – kg/min						20.8	20.1	19.5	20.3	FUEL FLOW – kg/min	23.6	25.3
	FUEL USED – kg/Anm						2.9	2.6	2.4	2.4	FUEL USED – kg/Anm	2.7	2.8
	DISTANCE – Anm/100kg						34.5	38.1	41.6	42.3	DISTANCE – Anm/100kg	37.7	35.4
	ENG. SPEED – %RPM						97.4	96.1	94.8	95.0	MACH NUMBER	0.93	0.94
40 000 ft	FUEL FLOW – kg/min										FUEL FLOW – kg/min		
	FUEL USED – kg/Anm										FUEL USED – kg/Anm		
	DISTANCE – Anm/100kg										DISTANCE – Anm/100kg		
	ENG. SPEED – %RPM										MACH NUMBER		

LEVEL CRUISE, TWO ENGINES OPERATING – MASS 10 500kg, DRAG INDEX 20

JAGUAR GR.MK.1 T.MK.2
 DATA: ESTIMATED/FLIGHT TEST
 FUEL: AVTUR/FSII

ENGINES: ADOUR MK.102/JP103
 DATE OF ISSUE: MAY 1975

ALTITUDE		MACH NUMBER									POWER SETTING		
		0.50	0.55	0.60	0.65	0.70	0.75	0.80	0.85	0.90	MAX. CONT.	MAX. DRY	
SEA LEVEL	FUEL FLOW – kg/min	26.4	29.1	32.4	36.2	40.7	45.8	52.0	59.1		FUEL FLOW – kg/min	54.4	63.0
	FUEL USED – kg/Anm	4.8	4.8	4.9	5.1	5.3	5.5	5.9	6.3		FUEL USED – kg/Anm	6.0	6.6
	DISTANCE – Anm/100kg	20.9	20.8	20.4	19.8	19.0	18.0	17.0	15.9		DISTANCE – Anm/100kg	16.6	15.2
	ENG. SPEED – %RPM	88.1	89.8	91.0	92.6	94.3	95.8	97.7	99.6		MACH NUMBER	0.82	0.87
5 000 ft	FUEL FLOW – kg/min	24.8	25.5	28.0	31.0	34.5	38.6	43.5	49.4	61.3	FUEL FLOW – kg/min	52.7	61.3
	FUEL USED – kg/Anm	4.6	4.3	4.3	4.4	4.5	4.7	5.0	5.4	6.3	FUEL USED – kg/Anm	5.6	6.3
	DISTANCE – Anm/100kg	21.9	23.4	23.2	22.7	22.0	21.1	19.9	18.7	15.9	DISTANCE – Anm/100kg	17.9	15.9
	ENG. SPEED – %RPM	88.9	89.4	90.7	91.5	93.3	94.8	96.5	97.9	101.1	MACH NUMBER	0.87	0.90
10 000 ft	FUEL FLOW – kg/min	24.9	24.0	24.5	26.7	29.4	32.6	36.5	41.1	50.0	FUEL FLOW – kg/min	46.4	55.6
	FUEL USED – kg/Anm	4.7	4.1	3.8	3.9	4.0	4.1	4.3	4.6	5.2	FUEL USED – kg/Anm	5.0	5.7
	DISTANCE – Anm/100kg	21.4	24.4	26.0	25.9	25.3	24.5	23.3	22.0	19.1	DISTANCE – Anm/100kg	20.2	17.6
	ENG. SPEED – %RPM	90.5	89.9	89.9	91.2	92.5	93.7	95.3	96.9	100.0	MACH NUMBER	0.88	0.92
15 000 ft	FUEL FLOW – kg/min	26.1	24.3	23.5	23.5	25.4	27.9	30.8	34.5	41.7	FUEL FLOW – kg/min	41.7	52.1
	FUEL USED – kg/Anm	5.0	4.2	3.8	3.5	3.5	3.6	3.7	3.9	4.4	FUEL USED – kg/Anm	4.4	5.4
	DISTANCE – Anm/100kg	20.0	23.6	26.6	28.9	28.7	28.1	27.1	25.7	22.5	DISTANCE – Anm/100kg	22.5	18.6
	ENG. SPEED – %RPM	92.6	91.6	90.9	90.5	91.7	93.0	94.4	95.9	99.3	MACH NUMBER	0.90	0.93
20 000 ft	FUEL FLOW – kg/min	29.7	26.1	24.3	23.3	23.0	24.2	26.4	29.2	34.9	FUEL FLOW – kg/min	37.7	44.5
	FUEL USED – kg/Anm	5.8	4.6	4.0	3.5	3.2	3.2	3.2	3.4	3.8	FUEL USED – kg/Anm	4.0	4.6
	DISTANCE – Anm/100kg	17.2	21.6	25.3	28.5	31.1	31.7	31.0	29.8	26.4	DISTANCE – Anm/100kg	24.7	21.6
	ENG. SPEED – %RPM	97.2	94.2	92.6	92.1	91.5	92.2	93.5	94.9	97.9	MACH NUMBER	0.91	0.94
25 000 ft	FUEL FLOW – kg/min			27.3	24.5	23.2	22.8	23.0	24.8	29.2	FUEL FLOW – kg/min	33.4	40.5
	FUEL USED – kg/Anm			4.5	3.8	3.3	3.0	2.9	2.9	3.2	FUEL USED – kg/Anm	3.6	4.3
	DISTANCE – Anm/100kg			22.1	26.6	30.2	33.0	34.9	34.4	30.9	DISTANCE – Anm/100kg	27.6	23.3
	ENG. SPEED – %RPM			97.7	95.1	93.7	93.0	93.0	94.3	96.5	MACH NUMBER	0.92	0.94
30 000 ft	FUEL FLOW – kg/min						24.6	23.6	23.4	25.5	FUEL FLOW – kg/min	27.9	32.9
	FUEL USED – kg/Anm						3.3	3.0	2.8	2.9	FUEL USED – kg/Anm	3.1	3.6
	DISTANCE – Anm/100kg						29.9	33.3	35.7	34.7	DISTANCE – Anm/100kg	32.3	28.0
	ENG. SPEED – %RPM						97.2	95.8	95.3	96.5	MACH NUMBER	0.92	0.94
36 090 ft	FUEL FLOW – kg/min										FUEL FLOW – kg/min		
	FUEL USED – kg/Anm										FUEL USED – kg/Anm		
	DISTANCE – Anm/100kg										DISTANCE – Anm/100kg		
	ENG. SPEED – %RPM										MACH NUMBER		
40 000 ft	FUEL FLOW – kg/min										FUEL FLOW – kg/min		
	FUEL USED – kg/Anm										FUEL USED – kg/Anm		
	DISTANCE – Anm/100kg										DISTANCE – Anm/100kg		
	ENG. SPEED – %RPM										MACH NUMBER		

LEVEL CRUISE, TWO ENGINES OPERATING –MASS 9 000 kg, DRAG INDEX 40

JAGUAR GR.MK.1 T.MK.2
DATA: ESTIMATED FLIGHT TEST
FUEL: AVTUR F51

ENGINES: ADOUR MK.102 JP103
DATE OF ISSUE: MAY 1975

ALTITUDE		MACH NUMBER									POWER SETTING		
		0.50	0.55	0.60	0.65	0.70	0.75	0.80	0.85	0.90	MAX. CONT.	MAX. DRY	
SEA LEVEL	FUEL FLOW – kg/min	27.6	31.1	35.3	40.2	45.8	52.4	60.0			FUEL FLOW – kg/min	55.1	64.0
	FUEL USED – kg/Anm	5.0	5.1	5.3	5.6	5.8	6.3	6.8			FUEL USED – kg/Anm	6.5	7.1
	DISTANCE – Anm/100kg	20.0	19.5	18.7	17.8	16.9	15.8	14.7			DISTANCE – Anm/100kg	15.4	14.1
	ENG. SPEED – %RPM	89.4	90.6	92.2	94.4	96.1	97.8	99.8			MACH NUMBER	0.77	0.82
4 000 ft	FUEL FLOW – kg/min	24.7	27.6	31.1	35.1	39.8	45.4	52.0	61.6		FUEL FLOW – kg/min	52.0	61.6
	FUEL USED – kg/Anm	4.5	4.6	4.8	5.0	5.2	5.6	6.0	6.7		FUEL USED – kg/Anm	6.0	6.7
	DISTANCE – Anm/100kg	22.0	21.7	21.0	20.1	19.1	18.0	16.7	15.0		DISTANCE – Anm/100kg	16.7	15.0
	ENG. SPEED – %RPM	89.9	90.3	91.6	93.4	95.1	97.0	98.9	101.0		MACH NUMBER	0.80	0.85
8 000 ft	FUEL FLOW – kg/min	23.5	24.5	27.3	30.7	34.5	39.1	44.8	51.9		FUEL FLOW – kg/min	48.3	57.0
	FUEL USED – kg/Anm	4.4	4.2	4.3	4.4	4.6	4.9	5.2	5.7		FUEL USED – kg/Anm	5.5	6.1
	DISTANCE – Anm/100kg	22.8	24.0	23.5	22.7	21.7	20.5	19.1	17.5		DISTANCE – Anm/100kg	18.2	16.3
	ENG. SPEED – %RPM	89.0	89.6	90.8	92.6	94.0	95.9	98.0	100.0		MACH NUMBER	0.82	0.87
12 000 ft	FUEL FLOW – kg/min	23.1	23.1	24.3	27.0	30.1	33.9	38.5	44.7		FUEL FLOW – kg/min	44.7	51.1
	FUEL USED – kg/Anm	4.4	4.0	3.8	3.9	4.1	4.3	4.6	5.0		FUEL USED – kg/Anm	5.0	5.4
	DISTANCE – Anm/100kg	22.9	25.2	26.1	25.5	24.5	23.3	21.9	20.1		DISTANCE – Anm/100kg	20.1	18.4
	ENG. SPEED – %RPM	90.0	90.0	90.4	91.7	93.4	94.8	97.0	98.9		MACH NUMBER	0.85	0.89
16 000 ft	FUEL FLOW – kg/min	23.2	22.6	22.7	23.9	26.4	29.5	33.3	38.4		FUEL FLOW – kg/min	39.8	44.4
	FUEL USED – kg/Anm	4.5	3.9	3.6	3.5	3.6	3.8	4.0	4.3		FUEL USED – kg/Anm	4.5	4.8
	DISTANCE – Anm/100kg	22.4	25.3	27.5	28.3	27.5	26.5	25.0	23.0		DISTANCE – Anm/100kg	22.4	20.8
	ENG. SPEED – %RPM	91.1	90.6	90.6	90.8	92.6	94.0	95.6	97.8		MACH NUMBER	0.86	0.89
20 000 ft	FUEL FLOW – kg/min	24.3	22.9	22.3	22.4	23.4	25.9	28.9	33.1	41.3	FUEL FLOW – kg/min	35.8	41.3
	FUEL USED – kg/Anm	4.8	4.1	3.6	3.4	3.3	3.4	3.5	3.8	4.5	FUEL USED – kg/Anm	4.0	4.5
	DISTANCE – Anm/100kg	21.0	24.6	27.5	29.6	30.6	29.7	28.3	26.3	22.3	DISTANCE – Anm/100kg	24.8	22.3
	ENG. SPEED – %RPM	93.4	91.8	91.1	91.5	92.0	93.1	95.0	96.9	100.9	MACH NUMBER	0.87	0.90
24 000 ft	FUEL FLOW – kg/min	27.3	24.1	22.6	22.1	22.1	22.9	25.1	28.5	35.5	FUEL FLOW – kg/min	32.8	37.9
	FUEL USED – kg/Anm	5.4	4.3	3.7	3.4	3.1	3.0	3.1	3.3	3.9	FUEL USED – kg/Anm	3.7	4.1
	DISTANCE – Anm/100kg	18.5	23.0	26.7	29.7	31.8	33.0	32.1	30.0	25.5	DISTANCE – Anm/100kg	27.0	24.2
	ENG. SPEED – %RPM	97.6	94.8	93.0	92.3	92.2	92.5	94.4	96.0	99.8	MACH NUMBER	0.88	0.91
28 000 ft	FUEL FLOW – kg/min			24.9	23.0	22.2	22.3	22.9	25.0	30.8	FUEL FLOW – kg/min	29.6	33.8
	FUEL USED – kg/Anm			4.2	3.6	3.2	3.0	2.9	3.0	3.5	FUEL USED – kg/Anm	3.4	3.8
	DISTANCE – Anm/100kg			23.9	28.0	31.2	33.3	34.5	33.7	29.0	DISTANCE – Anm/100kg	29.8	26.7
	ENG. SPEED – %RPM			97.5	94.9	94.2	94.0	94.3	95.5	99.2	MACH NUMBER	0.89	0.91
32 000 ft	FUEL FLOW – kg/min					25.1	23.1	22.9	23.7	27.4	FUEL FLOW – kg/min	25.6	29.4
	FUEL USED – kg/Anm					3.7	3.2	2.9	2.9	3.1	FUEL USED – kg/Anm	3.0	3.3
	DISTANCE – Anm/100kg					27.1	31.6	34.0	34.9	32.0	DISTANCE – Anm/100kg	33.5	30.2
	ENG. SPEED – %RPM					98.4	96.8	96.2	96.5	99.3	MACH NUMBER	0.88	0.91

LEVEL CRUISE, TWO ENGINES OPERATING – MASS 11 000kg, DRAG INDEX 40

JAGUAR GR.MK.1 T.MK.2
DATA: ESTIMATED FLIGHT TEST
FUEL: AVTUR/FSII

ENGINES: ADOUR MK.102/JP103
DATE OF ISSUE: MAY 1975

ALTITUDE		MACH NUMBER									POWER SETTING		
		0.50	0.55	0.60	0.65	0.70	0.75	0.80	0.85	0.90	MAX. CONT.	MAX. DRY	
SEA LEVEL	FUEL FLOW – kg/min	29.9	32.7	36.7	41.4	46.8	53.3	60.8			FUEL FLOW – kg/min	53.7	65.0
	FUEL USED – kg/Anm	5.4	5.4	5.5	5.8	6.1	6.4	6.9			FUEL USED – kg/Anm	6.5	7.3
	DISTANCE – Anm/100kg	18.4	18.5	18.0	17.3	16.5	15.5	14.5			DISTANCE – Anm/100kg	15.4	13.9
	ENG. SPEED – %RPM	90.2	91.5	93.1	94.6	96.5	98.3	100.2			MACH NUMBER	0.75	0.82
4 000 ft	FUEL FLOW – kg/min	28.9	29.4	32.6	36.5	41.0	46.5	53.0	65.0		FUEL FLOW – kg/min	51.4	65.0
	FUEL USED – kg/Anm	5.3	4.9	5.0	5.2	5.4	5.7	6.1	7.0		FUEL USED – kg/Anm	6.0	7.0
	DISTANCE – Anm/100kg	18.8	20.3	20.0	19.4	18.6	17.5	16.4	14.2		DISTANCE – Anm/100kg	16.7	14.2
	ENG. SPEED – %RPM	90.9	91.3	92.5	94.0	95.6	97.4	99.2	101.0		MACH NUMBER	0.79	0.85
8 000 ft	FUEL FLOW – kg/min	28.6	28.3	29.1	32.2	35.9	40.4	46.0	53.0		FUEL FLOW – kg/min	47.5	57.9
	FUEL USED – kg/Anm	5.3	4.8	4.5	4.6	4.8	5.0	5.4	5.8		FUEL USED – kg/Anm	5.5	6.2
	DISTANCE – Anm/100kg	18.7	20.8	22.1	21.6	20.9	19.9	18.7	17.2		DISTANCE – Anm/100kg	18.3	16.1
	ENG. SPEED – %RPM	91.9	91.8	91.8	93.3	94.8	96.5	98.4	100.3		MACH NUMBER	0.81	0.87
12 000 ft	FUEL FLOW – kg/min	28.9	28.0	27.9	28.8	31.7	35.4	39.9	45.9		FUEL FLOW – kg/min	43.3	53.0
	FUEL USED – kg/Anm	5.5	4.8	4.4	4.2	4.3	4.5	4.7	5.1		FUEL USED – kg/Anm	5.0	5.7
	DISTANCE – Anm/100kg	18.2	20.8	22.7	23.9	23.3	22.4	21.2	19.5		DISTANCE – Anm/100kg	20.2	17.7
	ENG. SPEED – %RPM	93.4	92.3	92.2	92.5	94.1	95.6	97.4	99.4		MACH NUMBER	0.83	0.89
16 000 ft	FUEL FLOW – kg/min	30.5	28.4	27.5	27.6	28.3	31.2	34.8	40.0		FUEL FLOW – kg/min	40.0	47.4
	FUEL USED – kg/Anm	5.9	5.0	4.4	4.1	3.9	4.0	4.2	4.5		FUEL USED – kg/Anm	4.5	5.1
	DISTANCE – Anm/100kg	17.0	20.2	22.6	24.5	25.7	25.0	23.9	22.1		DISTANCE – Anm/100kg	22.1	19.5
	ENG. SPEED – %RPM	95.7	94.5	93.3	93.3	93.6	95.0	96.5	98.7		MACH NUMBER	0.85	0.89
20 000 ft	FUEL FLOW – kg/min		30.8	28.4	27.4	27.4	28.3	30.7	35.0		FUEL FLOW – kg/min	36.3	43.9
	FUEL USED – kg/Anm		5.5	4.6	4.1	3.8	3.7	3.8	4.0		FUEL USED – kg/Anm	4.1	4.8
	DISTANCE – Anm/100kg		18.3	21.6	24.2	26.1	27.1	26.6	24.9		DISTANCE – Anm/100kg	24.2	21.0
	ENG. SPEED – %RPM		97.5	95.8	94.9	94.5	94.9	96.1	97.8		MACH NUMBER	0.86	0.90
24 000 ft	FUEL FLOW – kg/min				29.1	27.7	27.6	28.5	30.7		FUEL FLOW – kg/min	33.2	39.6
	FUEL USED – kg/Anm				4.4	3.9	3.7	3.5	3.6		FUEL USED – kg/Anm	3.8	4.4
	DISTANCE – Anm/100kg				22.5	25.4	27.3	28.4	27.8		DISTANCE – Anm/100kg	26.4	22.9
	ENG. SPEED – %RPM				97.8	96.5	96.1	96.2	97.2		MACH NUMBER	0.87	0.90
28 000 ft	FUEL FLOW – kg/min					29.1	28.8	29.7			FUEL FLOW – kg/min		34.7
	FUEL USED – kg/Anm					3.9	3.6	3.5			FUEL USED – kg/Anm		3.9
	DISTANCE – Anm/100kg					25.5	27.5	28.4			DISTANCE – Anm/100kg		25.4
	ENG. SPEED – %RPM					99.6	98.8	99.0			MACH NUMBER		0.89
32 000 ft	FUEL FLOW – kg/min										FUEL FLOW – kg/min		
	FUEL USED – kg/Anm										FUEL USED – kg/Anm		
	DISTANCE – Anm/100kg										DISTANCE – Anm/100kg		
	ENG. SPEED – %RPM										MACH NUMBER		

LEVEL CRUISE, TWO ENGINES OPERATING – MASS 13 000kg , DRAG INDEX 40

JAGUAR GR.MK.1 T.VK.2
DATA ESTIMATED FLIGHT TEST
FUEL AVTUR FS

ENGINES: ADOJR VK.102 J-P103
DATE OF ISSUE: MAY 1975

ALTITUDE		MACH NUMBER									POWER SETTING		
		0.50	0.55	0.60	0.65	0.70	0.75	0.80	0.85	0.90	MAX. CONT.	MAX. DRY	
SEA LEVEL	FUEL FLOW – kg/min	34.5	35.0	38.3	42.8	48.1	54.5	61.9			FUEL FLOW – kg/min	54.5	61.9
	FUEL USED – kg/Anm	6.3	5.8	5.8	6.0	6.2	6.6	7.0			FUEL USED – kg/Anm	6.6	7.0
	DISTANCE – Anm/100kg	16.0	17.3	17.3	16.7	16.0	15.2	14.3			DISTANCE – Anm/100kg	15.2	14.3
	ENG. SPEED – %RPM	92.4	92.4	93.6	95.2	96.9	98.7	100.7			MACH NUMBER	0.75	0.80
4 000 ft	FUEL FLOW – kg/min	34.2	33.8	34.5	38.1	42.4	47.8	54.2			FUEL FLOW – kg/min	52.0	61.2
	FUEL USED – kg/Anm	6.3	5.7	5.3	5.4	5.6	5.9	6.2			FUEL USED – kg/Anm	6.1	6.7
	DISTANCE – Anm/100kg	15.9	17.6	18.9	18.5	17.9	17.0	16.0			DISTANCE – Anm/100kg	16.3	14.9
	ENG. SPEED – %RPM	93.6	94.1	93.4	94.5	96.2	98.0	99.4			MACH NUMBER	0.78	0.84
8 000 ft	FUEL FLOW – kg/min	34.7	33.4	33.3	31.4	37.6	42.0	47.4	54.2		FUEL FLOW – kg/min	47.4	56.2
	FUEL USED – kg/Anm	6.5	5.7	5.2	4.9	5.0	5.2	5.5	6.0		FUEL USED – kg/Anm	5.5	6.1
	DISTANCE – Anm/100kg	15.4	17.6	19.3	20.4	20.0	19.2	18.1	16.8		DISTANCE – Anm/100kg	18.1	16.4
	ENG. SPEED – %RPM	94.9	94.1	94.0	94.1	95.3	96.9	98.9	100.8		MACH NUMBER	0.80	0.86
12 000 ft	FUEL FLOW – kg/min	36.9	34.1	33.0	32.9	33.8	37.1	41.6	47.4		FUEL FLOW – kg/min	44.1	53.3
	FUEL USED – kg/Anm	7.0	5.9	5.2	4.8	4.6	4.7	4.9	5.3		FUEL USED – kg/Anm	5.1	5.8
	DISTANCE – Anm/100kg	14.3	17.0	19.2	20.8	21.9	21.4	20.3	18.9		DISTANCE – Anm/100kg	19.6	17.4
	ENG. SPEED – %RPM	97.2	95.8	95.0	94.9	95.2	96.5	97.8	99.8		MACH NUMBER	0.82	0.88
16 000 ft	FUEL FLOW – kg/min		37.8	34.1	32.9	32.8	33.8	36.9	41.8		FUEL FLOW – kg/min	40.8	48.5
	FUEL USED – kg/Anm		6.5	5.5	4.9	4.5	4.3	4.4	4.7		FUEL USED – kg/Anm	4.7	5.2
	DISTANCE – Anm/100kg		15.4	18.3	20.6	22.2	23.1	22.6	21.2		DISTANCE – Anm/100kg	21.4	19.1
	ENG. SPEED – %RPM		99.2	97.3	96.2	95.9	96.2	97.3	99.2		MACH NUMBER	0.84	0.89
20 000 ft	FUEL FLOW – kg/min				35.1	33.6	33.5	34.5	37.2		FUEL FLOW – kg/min	35.1	41.7
	FUEL USED – kg/Anm				5.3	4.7	4.4	4.2	4.3		FUEL USED – kg/Anm	4.2	4.6
	DISTANCE – Anm/100kg				19.0	21.3	22.9	23.8	23.4		DISTANCE – Anm/100kg	23.9	21.6
	ENG. SPEED – %RPM				99.4	98.4	97.7	98.1	99.0		MACH NUMBER	0.82	0.88
24 000 ft	FUEL FLOW – kg/min							34.5	35.6		FUEL FLOW – kg/min		35.6
	FUEL USED – kg/Anm							4.3	4.2		FUEL USED – kg/Anm		4.2
	DISTANCE – Anm/100kg							23.3	24.0		DISTANCE – Anm/100kg		24.0
	ENG. SPEED – %RPM							100.4	100.6		MACH NUMBER		0.85
28 000 ft	FUEL FLOW – kg/min										FUEL FLOW – kg/min		
	FUEL USED – kg/Anm										FUEL USED – kg/Anm		
	DISTANCE – Anm/100kg										DISTANCE – Anm/100kg		
	ENG. SPEED – %RPM										MACH NUMBER		
32 000 ft	FUEL FLOW – kg/min										FUEL FLOW – kg/min		
	FUEL USED – kg/Anm										FUEL USED – kg/Anm		
	DISTANCE – Anm/100kg										DISTANCE – Anm/100kg		
	ENG. SPEED – %RPM										MACH NUMBER		

LEVEL CRUISE , TWO ENGINES OPERATING – MASS 11 000 kg, DRAG INDEX 60

JAGUAR GR.MK.1 T.MK.2
 DATA: ESTIMATED/FLIGHT TEST
 FUEL: AVTUR/FSH

ENGINES: ADOUR MK.102/JP103
 DATE OF ISSUE: MAY 1975

ALTITUDE		MACH NUMBER									POWER SETTING		
		0.50	0.55	0.60	0.65	0.70	0.75	0.80	0.85	0.90	MAX. CONT.	MAX. DRY	
SEA LEVEL	FUEL FLOW – kg/min	32.5	36.0	40.7	46.3	53.0	60.7				FUEL FLOW – kg/min	54.0	63.8
	FUEL USED – kg/Anm	5.9	5.9	6.2	6.5	6.9	7.3				FUEL USED – kg/Anm	6.9	7.5
	DISTANCE – Anm/100kg	16.9	16.9	16.3	15.5	14.6	13.6				DISTANCE – Anm/100kg	14.5	13.3
	ENG. SPEED – %RPM	91.6	92.8	94.5	96.5	98.4	100.5				MACH NUMBER	0.71	0.77
4 000 ft	FUEL FLOW – kg/min	31.2	32.2	36.0	40.7	46.3	53.0	64.4			FUEL FLOW – kg/min	51.1	64.4
	FUEL USED – kg/Anm	5.7	5.4	5.5	5.8	6.1	6.5	7.4			FUEL USED – kg/Anm	6.4	7.4
	DISTANCE – Anm/100kg	17.4	18.6	18.1	17.4	16.4	15.4	13.5			DISTANCE – Anm/100kg	15.7	13.5
	ENG. SPEED – %RPM	91.8	92.2	93.8	95.6	97.5	99.5	101.3			MACH NUMBER	0.74	0.80
8 000 ft	FUEL FLOW – kg/min	30.5	30.7	32.0	35.8	40.3	46.1	52.7			FUEL FLOW – kg/min	47.4	56.6
	FUEL USED – kg/Anm	5.7	5.2	5.0	5.1	5.4	5.7	6.1			FUEL USED – kg/Anm	5.8	6.4
	DISTANCE – Anm/100kg	17.6	19.4	20.1	19.5	18.6	17.4	16.3			DISTANCE – Anm/100kg	17.2	15.5
	ENG. SPEED – %RPM	92.8	93.7	93.4	94.9	96.5	98.4	100.4			MACH NUMBER	0.76	0.82
12 000 ft	FUEL FLOW – kg/min	30.6	30.0	30.3	31.8	35.4	40.2	45.9			FUEL FLOW – kg/min	43.4	52.7
	FUEL USED – kg/Anm	5.8	5.2	4.8	4.6	4.8	5.1	5.4			FUEL USED – kg/Anm	5.3	6.0
	DISTANCE – Anm/100kg	17.3	19.4	20.9	21.6	20.9	19.7	18.4			DISTANCE – Anm/100kg	19.0	16.8
	ENG. SPEED – %RPM	94.4	93.7	93.7	94.5	95.9	97.9	99.8			MACH NUMBER	0.78	0.84
16 000 ft	FUEL FLOW – kg/min	32.2	30.3	29.7	30.2	31.5	35.2	40.1	48.6		FUEL FLOW – kg/min	39.1	48.6
	FUEL USED – kg/Anm	6.2	5.3	4.8	4.5	4.3	4.5	4.8	5.5		FUEL USED – kg/Anm	4.8	5.5
	DISTANCE – Anm/100kg	16.1	18.9	21.0	22.4	23.1	22.1	20.8	18.2		DISTANCE – Anm/100kg	21.0	18.2
	ENG. SPEED – %RPM	96.5	95.3	94.8	94.9	95.3	96.9	99.2	101.0		MACH NUMBER	0.79	0.85
20 000 ft	FUEL FLOW – kg/min		33.0	30.7	30.0	30.4	31.8	35.3	41.5		FUEL FLOW – kg/min	35.3	41.5
	FUEL USED – kg/Anm		5.9	5.0	4.5	4.2	4.1	4.3	4.8		FUEL USED – kg/Anm	4.3	4.8
	DISTANCE – Anm/100kg		17.1	20.0	22.2	23.6	24.1	23.2	21.0		DISTANCE – Anm/100kg	23.2	21.0
	ENG. SPEED – %RPM		98.9	97.2	96.3	96.3	96.9	98.6	101.0		MACH NUMBER	0.80	0.85
24 000 ft	FUEL FLOW – kg/min				32.2	30.8	31.2	32.6	35.8		FUEL FLOW – kg/min		35.8
	FUEL USED – kg/Anm				4.9	4.4	4.1	4.0	4.2		FUEL USED – kg/Anm		4.2
	DISTANCE – Anm/100kg				20.3	22.9	24.2	24.7	23.9		DISTANCE – Anm/100kg		23.9
	ENG. SPEED – %RPM				99.8	98.9	98.8	99.2	100.6		MACH NUMBER		0.85
28 000 ft	FUEL FLOW – kg/min										FUEL FLOW – kg/min		
	FUEL USED – kg/Anm										FUEL USED – kg/Anm		
	DISTANCE – Anm/100kg										DISTANCE – Anm/100kg		
	ENG. SPEED – %RPM										MACH NUMBER		
32 000 ft	FUEL FLOW – kg/min										FUEL FLOW – kg/min		
	FUEL USED – kg/Anm										FUEL USED – kg/Anm		
	DISTANCE – Anm/100kg										DISTANCE – Anm/100kg		
	ENG. SPEED – %RPM										MACH NUMBER		

LEVEL CRUISE, TWO ENGINES OPERATING – MASS 13 000 kg, DRAG INDEX 60

JAGUAR GR.MK.1 T.MK.2
 DATA: ESTIMATED/FLIGHT TEST
 FUEL: AVTUR/FSH

ENGINES: ADOUR MK.102/JP103
 DATE OF ISSUE: MAY 1975

ALTITUDE		MACH NUMBER									POWER SETTING		
		0.50	0.55	0.60	0.65	0.70	0.75	0.80	0.85	0.90	MAX. CONT.	MAX. DRY	
SEA LEVEL	FUEL FLOW – kg/min	37.1	38.2	42.4	47.8	53.4	61.9				FUEL FLOW – kg/min	54.3	61.9
	FUEL USED – kg/Anm	6.7	6.3	6.4	6.7	7.0	7.5				FUEL USED – kg/Anm	7.0	7.5
	DISTANCE – Anm/100kg	14.8	15.9	15.6	15.0	14.2	13.4				DISTANCE – Anm/100kg	14.2	13.4
	ENG. SPEED – %RPM	93.8	93.7	95.3	97.0	98.8	101.0				MACH NUMBER	0.70	0.75
4 000 ft	FUEL FLOW – kg/min	36.5	36.6	37.9	42.3	47.8	54.3				FUEL FLOW – kg/min	50.5	60.0
	FUEL USED – kg/Anm	6.7	6.1	5.8	6.0	6.3	6.7				FUEL USED – kg/Anm	6.5	7.1
	DISTANCE – Anm/100kg	14.9	16.3	17.2	16.7	15.9	15.0				DISTANCE – Anm/100kg	15.5	14.1
	ENG. SPEED – %RPM	94.4	94.4	94.6	96.2	98.0	99.9				MACH NUMBER	0.72	0.78
8 000 ft	FUEL FLOW – kg/min	36.7	35.9	36.2	37.7	42.1	47.7	54.1			FUEL FLOW – kg/min	47.7	54.1
	FUEL USED – kg/Anm	6.9	6.1	5.6	5.4	5.6	5.9	6.3			FUEL USED – kg/Anm	5.9	6.3
	DISTANCE – Anm/100kg	14.6	16.4	17.7	18.5	17.8	16.9	15.8			DISTANCE – Anm/100kg	16.9	15.8
	ENG. SPEED – %RPM	95.8	95.3	95.3	95.7	97.5	98.9	101.3			MACH NUMBER	0.75	0.80
12 000 ft	FUEL FLOW – kg/min	39.0	36.4	35.6	36.1	37.7	42.1	47.6			FUEL FLOW – kg/min	42.1	52.0
	FUEL USED – kg/Anm	7.4	6.3	5.6	5.3	5.1	5.3	5.6			FUEL USED – kg/Anm	5.3	6.0
	DISTANCE – Anm/100kg	13.5	16.0	17.8	19.0	19.6	18.8	17.8			DISTANCE – Anm/100kg	18.8	16.8
	ENG. SPEED – %RPM	98.4	96.9	96.5	96.5	96.9	98.3	100.2			MACH NUMBER	0.75	0.83
16 000 ft	FUEL FLOW – kg/min		40.4	36.9	36.1	36.5	38.3	42.1			FUEL FLOW – kg/min	38.3	46.2
	FUEL USED – kg/Anm		7.1	5.9	5.3	5.0	4.9	5.1			FUEL USED – kg/Anm	4.9	5.4
	DISTANCE – Anm/100kg		14.2	16.9	18.7	19.9	20.4	19.7			DISTANCE – Anm/100kg	20.4	18.7
	ENG. SPEED – %RPM		100.4	98.8	98.2	98.2	98.7	100.0			MACH NUMBER	0.75	0.83
20 000 ft	FUEL FLOW – kg/min					37.7	37.6	39.7			FUEL FLOW – kg/min		39.7
	FUEL USED – kg/Anm					5.3	4.9	4.9			FUEL USED – kg/Anm		4.9
	DISTANCE – Anm/100kg					19.0	20.4	20.6			DISTANCE – Anm/100kg		20.6
	ENG. SPEED – %RPM					100.3	100.0	100.6			MACH NUMBER		0.80
24 000 ft	FUEL FLOW – kg/min										FUEL FLOW – kg/min		
	FUEL USED – kg/Anm										FUEL USED – kg/Anm		
	DISTANCE – Anm/100kg										DISTANCE – Anm/100kg		
	ENG. SPEED – %RPM										MACH NUMBER		
28 000 ft	FUEL FLOW – kg/min										FUEL FLOW – kg/min		
	FUEL USED – kg/Anm										FUEL USED – kg/Anm		
	DISTANCE – Anm/100kg										DISTANCE – Anm/100kg		
	ENG. SPEED – %RPM										MACH NUMBER		
32 000 ft	FUEL FLOW – kg/min										FUEL FLOW – kg/min		
	FUEL USED – kg/Anm										FUEL USED – kg/Anm		
	DISTANCE – Anm/100kg										DISTANCE – Anm/100kg		
	ENG. SPEED – %RPM										MACH NUMBER		

LEVEL CRUISE, TWO ENGINES OPERATING – MASS 15 000 kg, DRAG INDEX 60

JAGUAR GR.MK.1 T.MK.2
 DATA: ESTIMATED/FLIGHT TEST
 FUEL: AVTUR/FSII

ENGINES: ADOUR MK.102/JP103
 DATE OF ISSUE: MAY 1975

ALTITUDE		MACH NUMBER									POWER SETTING		
		0.50	0.55	0.60	0.65	0.70	0.75	0.80	0.85	0.90	MAX. CONT.	MAX. DRY	
SEA LEVEL	FUEL FLOW – kg/min	42.6	42.8	44.3	49.6	55.8	65.9				FUEL FLOW – kg/min	54.4	65.9
	FUEL USED – kg/Anm	7.7	7.1	6.7	6.9	7.2	8.0				FUEL USED – kg/Anm	7.1	8.0
	DISTANCE – Anm/100kg	12.9	14.2	14.9	14.4	13.8	12.5				DISTANCE – Anm/100kg	14.0	12.5
	ENG. SPEED – %RPM	95.6	95.6	95.9	97.4	99.3	101.0				MACH NUMBER	0.69	0.75
4 000 ft	FUEL FLOW – kg/min	43.0	41.9	42.4	44.4	49.6	55.9				FUEL FLOW – kg/min	51.0	61.7
	FUEL USED – kg/Anm	7.9	7.0	6.5	6.3	6.5	6.9				FUEL USED – kg/Anm	6.6	7.3
	DISTANCE – Anm/100kg	12.7	14.3	15.4	15.9	15.3	14.6				DISTANCE – Anm/100kg	15.1	13.7
	ENG. SPEED – %RPM	96.9	96.5	96.5	96.9	98.5	100.4				MACH NUMBER	0.71	0.78
8 000 ft	FUEL FLOW – kg/min	45.3	42.6	41.8	42.4	44.3	49.5	58.5			FUEL FLOW – kg/min	46.8	58.5
	FUEL USED – kg/Anm	8.5	7.2	6.5	6.1	5.9	6.2	6.8			FUEL USED – kg/Anm	6.0	6.8
	DISTANCE – Anm/100kg	11.8	13.8	15.4	16.4	16.9	16.2	14.7			DISTANCE – Anm/100kg	16.7	14.7
	ENG. SPEED – %RPM	99.5	98.3	97.4	97.5	97.9	99.9	101.3			MACH NUMBER	0.73	0.80
12 000 ft	FUEL FLOW – kg/min			42.8	42.1	42.8	44.8	49.7			FUEL FLOW – kg/min		49.7
	FUEL USED – kg/Anm			6.8	6.1	5.8	5.7	5.9			FUEL USED – kg/Anm		5.9
	DISTANCE – Anm/100kg			14.8	16.3	17.3	17.7	17.0			DISTANCE – Anm/100kg		17.0
	ENG. SPEED – %RPM			99.9	99.1	99.2	99.7	101.2			MACH NUMBER		0.80
16 000 ft	FUEL FLOW – kg/min						45.3				FUEL FLOW – kg/min		45.3
	FUEL USED – kg/Anm						5.8				FUEL USED – kg/Anm		5.8
	DISTANCE – Anm/100kg						17.2				DISTANCE – Anm/100kg		17.2
	ENG. SPEED – %RPM						100.8				MACH NUMBER		0.75
20 000 ft	FUEL FLOW – kg/min										FUEL FLOW – kg/min		
	FUEL USED – kg/Anm										FUEL USED – kg/Anm		
	DISTANCE – Anm/100kg										DISTANCE – Anm/100kg		
	ENG. SPEED – %RPM										MACH NUMBER		
24 000 ft	FUEL FLOW – kg/min										FUEL FLOW – kg/min		
	FUEL USED – kg/Anm										FUEL USED – kg/Anm		
	DISTANCE – Anm/100kg										DISTANCE – Anm/100kg		
	ENG. SPEED – %RPM										MACH NUMBER		
28 000 ft	FUEL FLOW – kg/min										FUEL FLOW – kg/min		
	FUEL USED – kg/Anm										FUEL USED – kg/Anm		
	DISTANCE – Anm/100kg										DISTANCE – Anm/100kg		
	ENG. SPEED – %RPM										MACH NUMBER		
32 000 ft	FUEL FLOW – kg/min										FUEL FLOW – kg/min		
	FUEL USED – kg/Anm										FUEL USED – kg/Anm		
	DISTANCE – Anm/100kg										DISTANCE – Anm/100kg		
	ENG. SPEED – %RPM										MACH NUMBER		

Descent

Time, distance and fuel used for descents to 1000 ft are presented as functions of mass, initial altitude and drag index value. Data for descents to intermediate altitudes are obtained by subtraction.

The effect of ambient temperature on descend performance is negligible.

One chart shows tactical descent with airbrakes out, the other one without airbrakes.

TACTICAL CLEAR WEATHER DESCENT TO 1000 FT

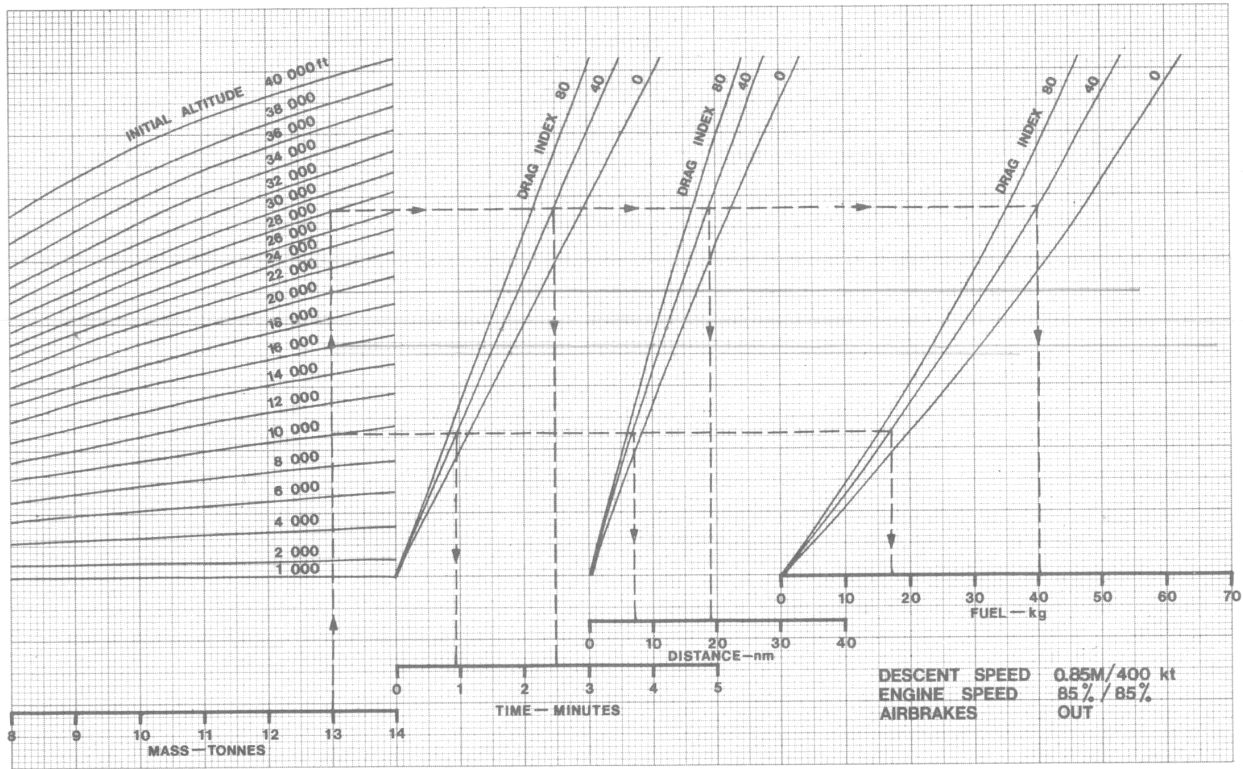

RANGE DESCENT TO 1000 FT

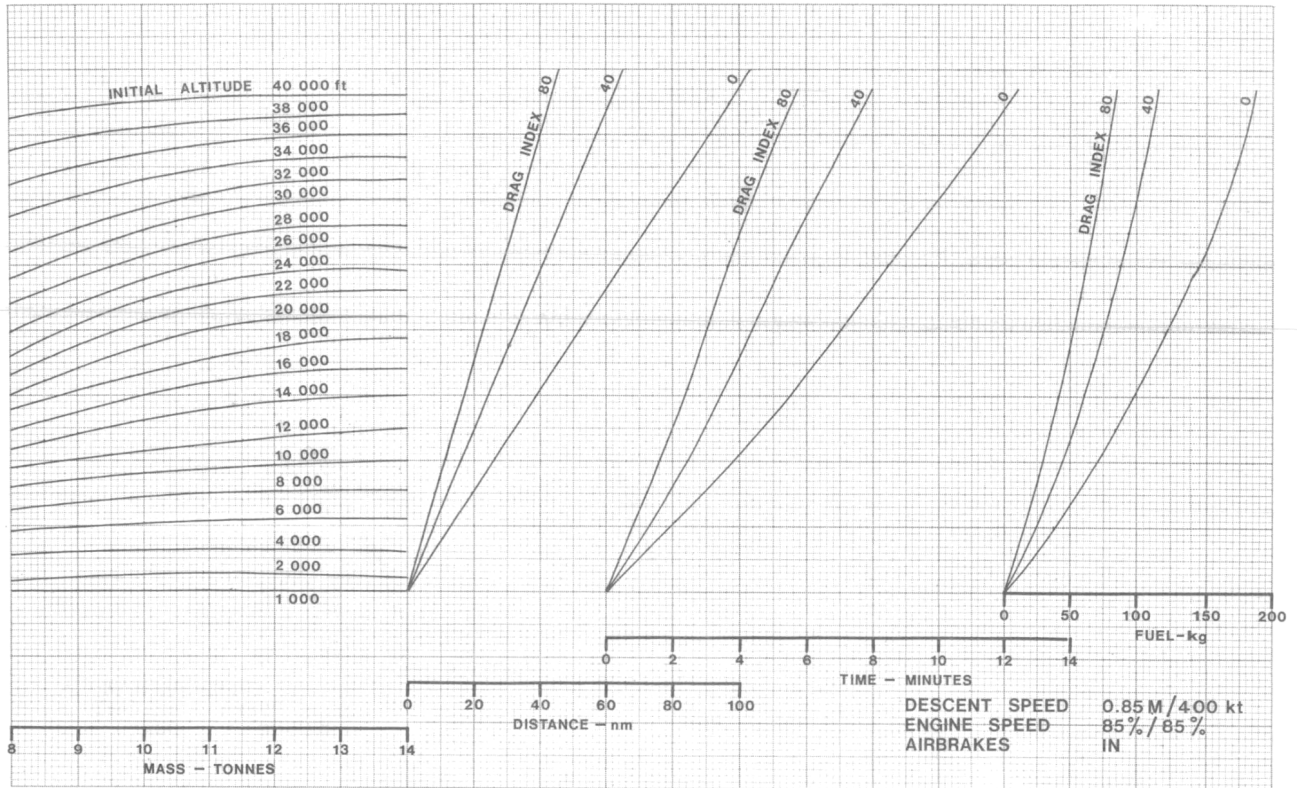

Landing

The recommended normal landing technique involves a 3 degrees glideslope at 12 degrees incidence, aiming to touch down at a sink rate of 100 ft/min.

The nose wheel is lowered onto the runway 2 seconds after the main wheels. Wheel braking is applied either at nose wheel touchdown or when speed has reduced to the maximum braking speed.

NORMAL LANDING SPEEDS

JAGUAR GR.MK.1 T.MK.2
DATA: ESTIMATED/FLIGHT TEST
FUEL: AVTUR/FSII

ENGINES: ADOUR MK.102/JP103
DATE OF ISSUE: MAY 1975

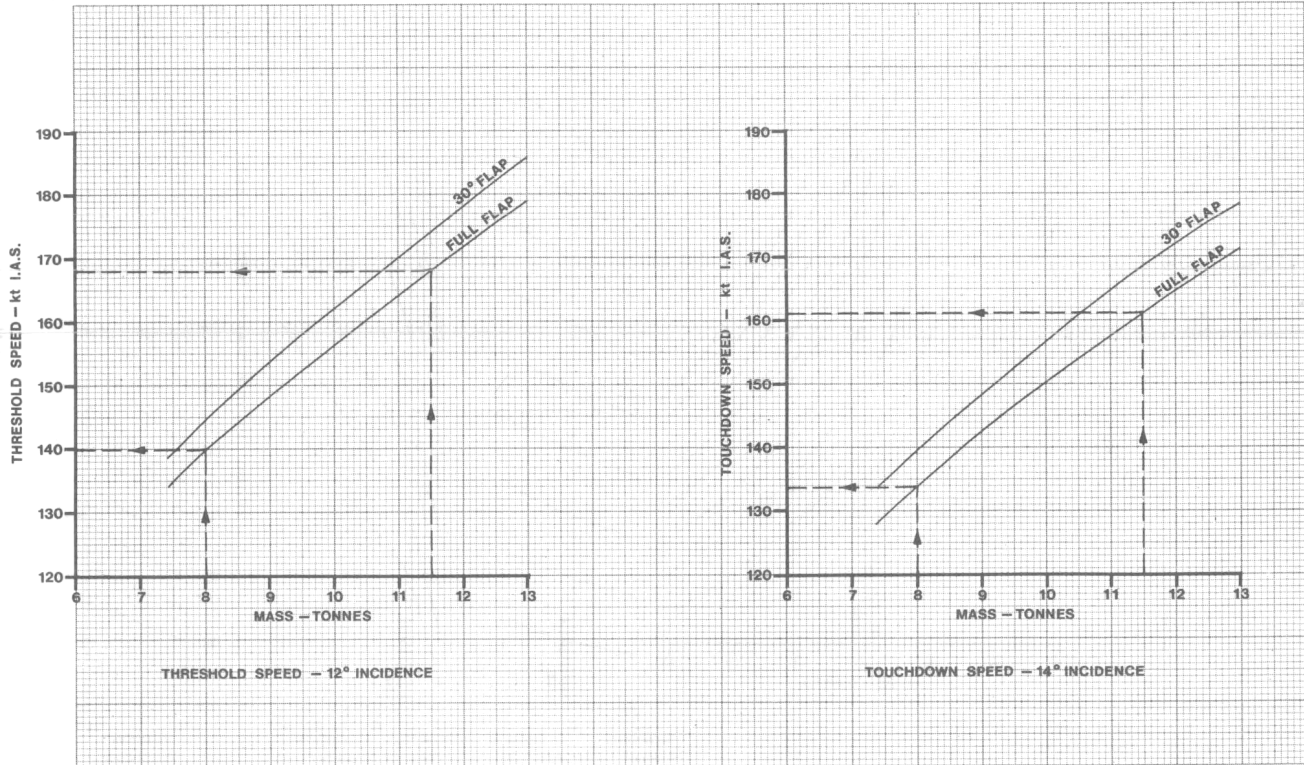

EMERGENCY MAXIMUM BRAKING SPEED – NO PARACHUTE

JAGUAR GR.MK.1 T.MK.2
 DATA: ESTIMATED/FLIGHT TEST
 FUEL: AVTUR/FSII

ENGINES: ADOUR MK.102/JP103
 DATE OF ISSUE: MAY 1975

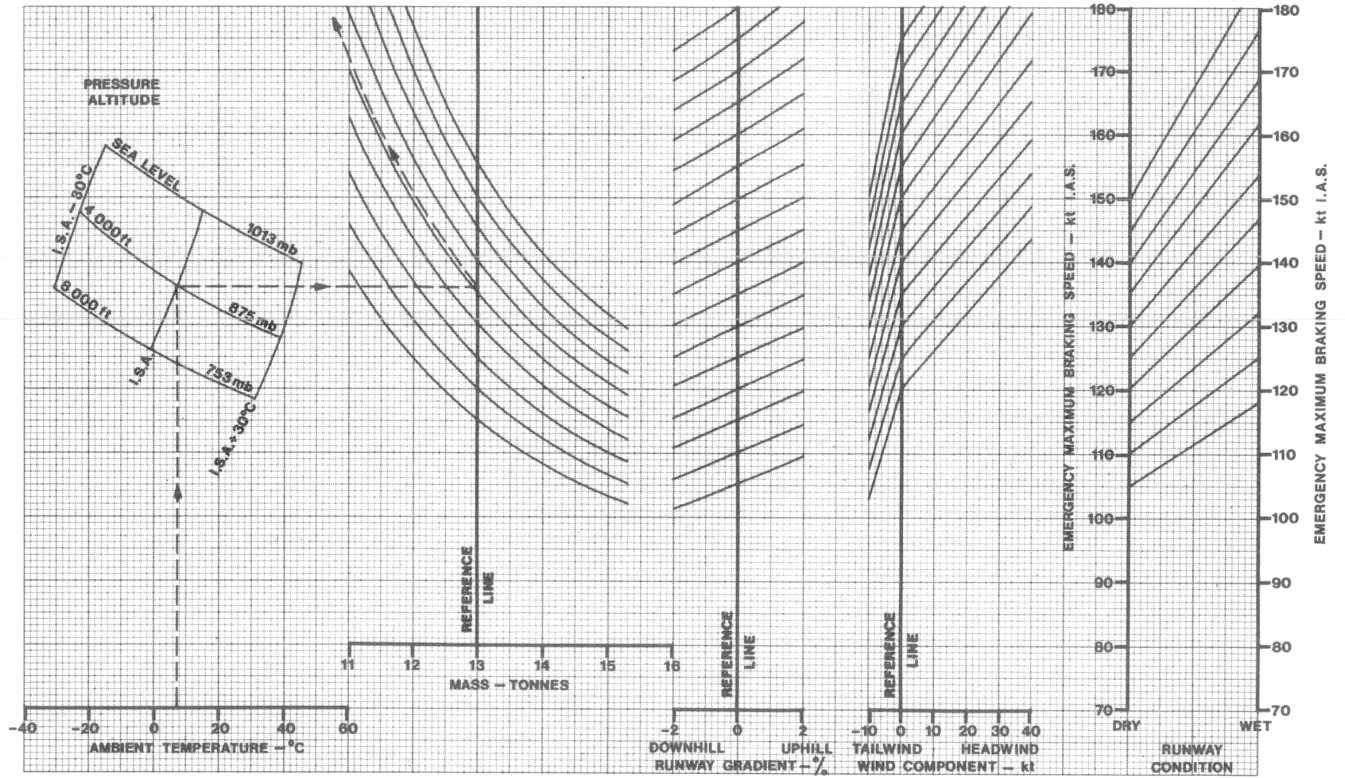

LANDING GROUND ROLL – NO PARACHUTE

JAGUAR GR.MK.1 T.MK.2
 DATA: ESTIMATED/FLIGHT TEST
 FUEL: AVTUR/FSII

ENGINES: ADOUR MK.102/JP103
 DATE OF ISSUE: MAY 1975

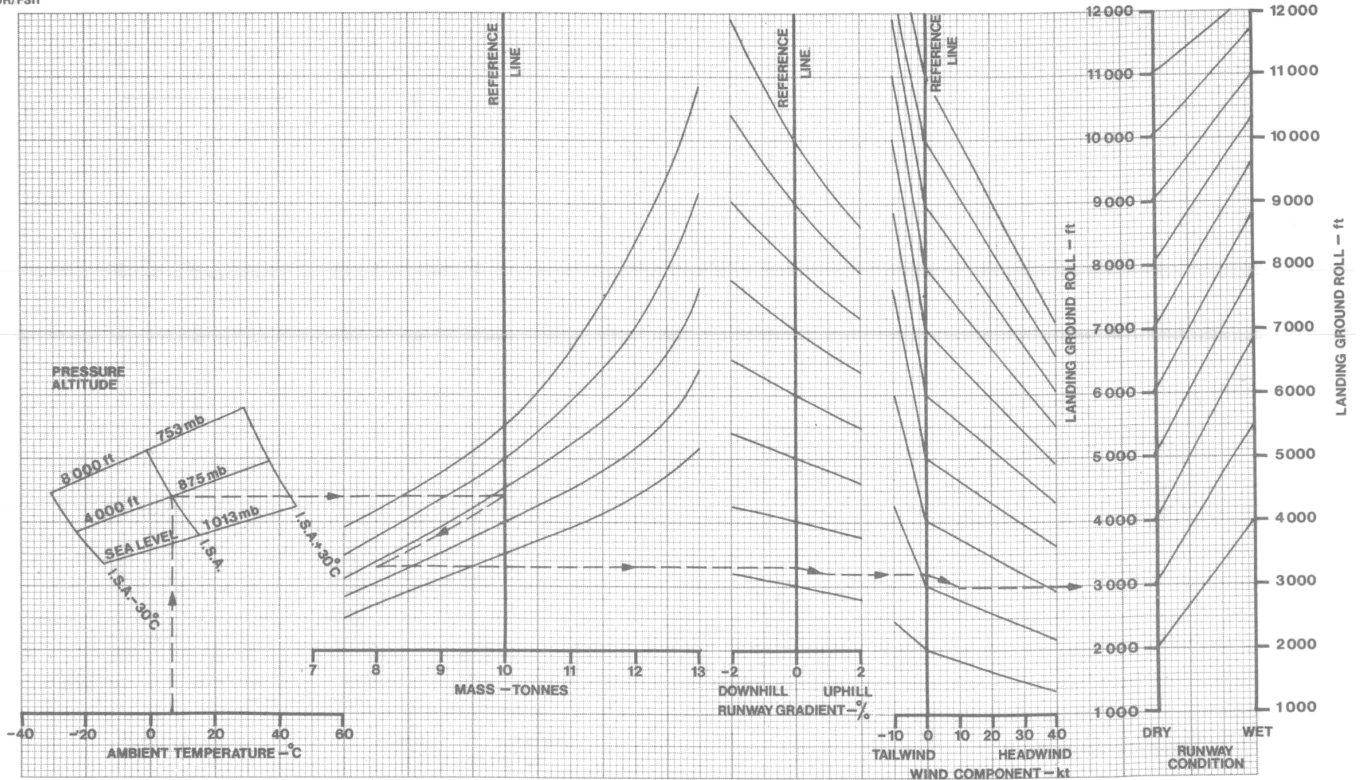

Controls assignments

In addition to default control assignments, our aircraft is using custom variables and events to manage all its systems.

Custom variables are called L Vars (prefixed with "L:") and custom events are called H Events (prefixed with "H:").

If you have external hardware and you are using specific software like FSUIPC or SPAD, you can assign buttons or switches to those variables and events.

In order to see custom variables related to the aircraft, you need to enable Developer mode (general options) and go to Tools > Behaviors > Local Variables on top menu bar. All custom variables are prefixed with "AZP_JAG" keyword.

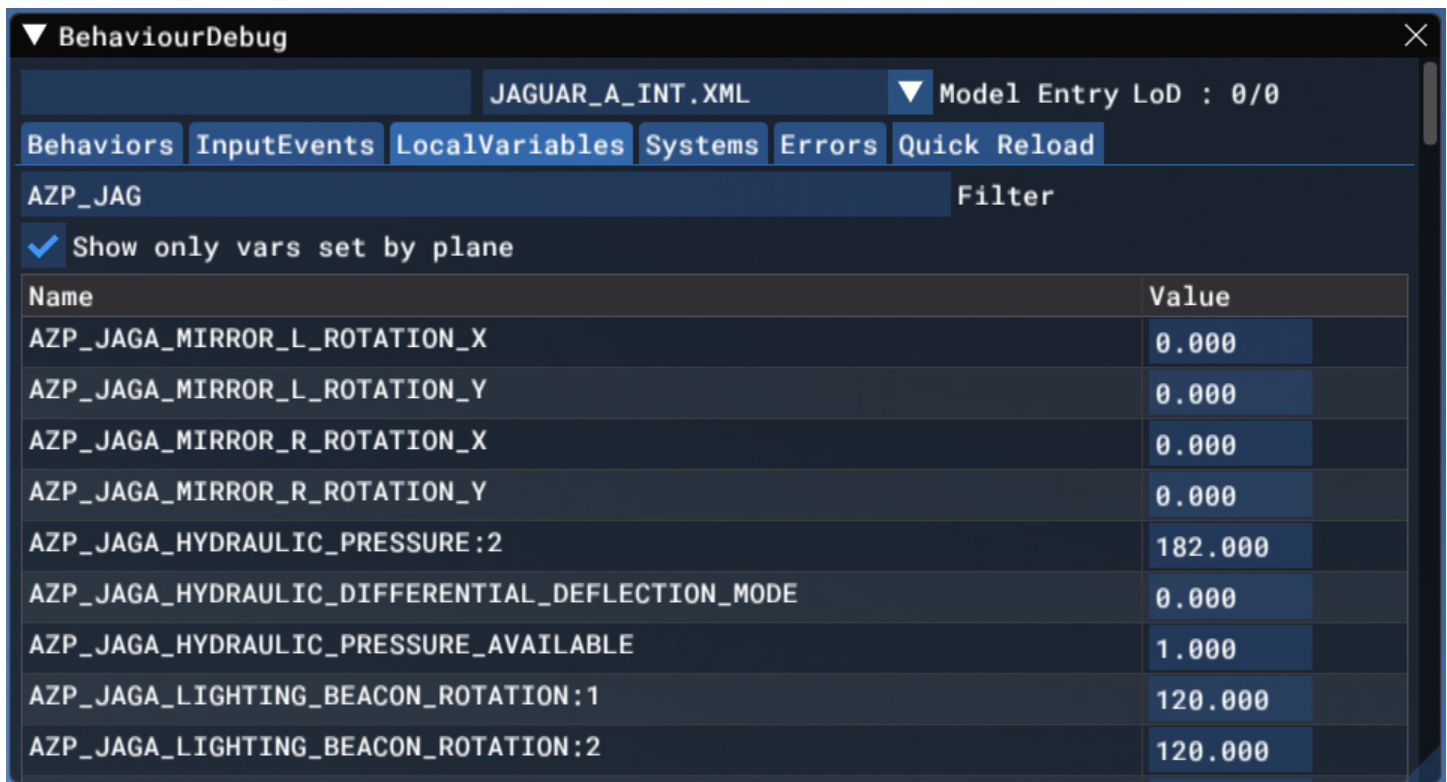

The screenshot shows the BehaviourDebug window for the JAGUAR_A_INT.XML model. The window has a dark theme and a top bar with the title "BehaviourDebug" and a close button. Below the title bar, there are tabs for "Behaviors", "InputEvents", "LocalVariables", "Systems", "Errors", and "Quick Reload". The "LocalVariables" tab is selected. Below the tabs, there is a search filter labeled "AZP_JAG" and a "Filter" button. A checkbox labeled "Show only vars set by plane" is checked. Below the checkbox is a table with two columns: "Name" and "Value".

Name	Value
AZP_JAGA_MIRROR_L_ROTATION_X	0.000
AZP_JAGA_MIRROR_L_ROTATION_Y	0.000
AZP_JAGA_MIRROR_R_ROTATION_X	0.000
AZP_JAGA_MIRROR_R_ROTATION_Y	0.000
AZP_JAGA_HYDRAULIC_PRESSURE:2	182.000
AZP_JAGA_HYDRAULIC_DIFFERENTIAL_DEFLECTION_MODE	0.000
AZP_JAGA_HYDRAULIC_PRESSURE_AVAILABLE	1.000
AZP_JAGA_LIGHTING_BEACON_ROTATION:1	120.000
AZP_JAGA_LIGHTING_BEACON_ROTATION:2	120.000

However, changing those L VARS is not always enough and you may need to call the events described in the next section.

Custom events

Here is non-exhaustive list of main H Events that you can use in order to interact with aircraft systems.

Name	H event	Description
EFB display	AZP_JAGA_TOGGLE_EFB_POWER	Display or hide EFB tablet
EFB position	AZP_JAGA_TOGGLE_EFB_POSITION	Switch between the two EFB positions
Chocks display	AZP_JAGA_TOGGLE_CHOCKS	Display or hide wheel chocks
Covers display	AZP_JAGA_TOGGLE_COVERS	Display or hide external covers
Ladder display	AZP_JAGA_LADDER_REMOVE	Remove ladder
Control locks display	AZP_JAGA_INTERIOR_RIBBON_REMOVE	Remove control locks (ribbon)
Yoke display	AZP_JAGA_TOGGLE_YOKE_VISIBILITY	Display or hide yoke
Canopy lock	AZP_JAGA_CANOPY_LOCK_TOGGLE	Toggle canopy lock
Canopy toggle	AZP_JAGA_CANOPY_TOGGLE	Open close canopy
Canopy repair	AZP_JAGA_CANOPY_REPAIR	Repair canopy once it has been jettisoned
External stores release	AZP_JAGA_STORES_EMERGENCY_RELEASE_PRESSED	Release all external stores
Engine starter switch	AZP_JAGA_ENGINE_STARTER_LEFT AZP_JAGA_ENGINE_STARTER_NEUTRAL AZP_JAGA_ENGINE_STARTER_RIGHT	Set engine starter switch position
Engine restart	AZP_JAGA_ENGINE_RESTART_LEFT AZP_JAGA_ENGINE_RESTART_RIGHT	Trigger in-flight restart

Name	H event	Description
buttons		
APU start switch	AZP_JAGA_APU_START_STOP_SWITCH_TOGGLE	Toggle APU start switch position
APU start button	AZP_JAGA_APU_STARTER_PUSHED	Start APU
Alternator switches	AZP_JAGA_ALTERNATOR_1_OFF AZP_JAGA_ALTERNATOR_1_ON AZP_JAGA_ALTERNATOR_1_REARM AZP_JAGA_ALTERNATOR_2_OFF AZP_JAGA_ALTERNATOR_2_ON AZP_JAGA_ALTERNATOR_2_REARM	Set alternator switches position
Rectifier switches	AZP_JAGA_RECTIFIER_1_OFF AZP_JAGA_RECTIFIER_1_ON AZP_JAGA_RECTIFIER_1_REARM AZP_JAGA_RECTIFIER_2_OFF AZP_JAGA_RECTIFIER_2_ON AZP_JAGA_RECTIFIER_2_REARM	Set rectifier switches position
Crash switches	AZP_JAGA_ELECTRICAL_CRASH_GROUP_TOGGLE AZP_JAGA_ELECTRICAL_CRASH_BATTERY_TOGGLE AZP_JAGA_ELECTRICAL_CRASH_ALT1_TOGGLE AZP_JAGA_ELECTRICAL_CRASH_ALT2_TOGGLE AZP_JAGA_ELECTRICAL_CRASH_EXTINGUISHERS_TOGGLE	Set crash switches position
Navigation lights	AZP_JAGA_LIGHTS_NAV_OFF AZP_JAGA_LIGHTS_NAV_FIXED_NORM AZP_JAGA_LIGHTS_NAV_FIXED_DIM AZP_JAGA_LIGHTS_NAV_FLASH	Set navigation lights switch position
Formation refuel lights	AZP_JAGA_LIGHTS_FORM_OFF AZP_JAGA_LIGHTS_FORM_EMER AZP_JAGA_LIGHTS_FORM_REFUEL_NORM AZP_JAGA_LIGHTS_FORM_NORM AZP_JAGA_LIGHTS_FORM_DIM	Set formation refuel lights switch position

Name	H event	Description
V1/V2 fuel valves	AZP_JAGA_FUEL_V1_V2_VALVES_TOGGLE	Toggle V1/V2 fuel valves
Fuel totalizer	AZP_JAGA_FUEL_TOTALIZER_INC AZP_JAGA_FUEL_TOTALIZER_DEC AZP_JAGA_FUEL_TOTALIZER_SET	Increase, decrease or set fuel totalizer
Hydraulic electro pump switch	AZP_JAGA_HYDRAULIC_ELECTRO_PUMP_EMER AZP_JAGA_HYDRAULIC_ELECTRO_PUMP_AUTO AZP_JAGA_HYDRAULIC_ELECTRO_PUMP_OFF	Set electro pump switch position
Emergency landing gear toggle	AZP_JAGA_HYDRAULIC_EMERGENCY_GEAR_TOGGLE	Extend landing gear in case of hydraulic failure
Rudder deflection switch	AZP_JAGA_HYDRAULIC_RUDDER_DEFLECTION_SWITCH_AUTO AZP_JAGA_HYDRAULIC_RUDDER_DEFLECTION_SWITCH_BIG AZP_JAGA_HYDRAULIC_RUDDER_DEFLECTION_SWITCH_SMALL	Set rudder deflection switch position
Autopilot master toggle	AZP_JAGA_AUTOPILOT_MASTER_TOGGLE	Toggle master autopilot
Autopilot ALT toggle	AZP_JAGA_AUTOPILOT_ALT_TOGGLE	Toggle autopilot ALT mode
Decision height index	AZP_JAGA_INSTRUMENT_DECISION_HEIGHT_1_INC AZP_JAGA_INSTRUMENT_DECISION_HEIGHT_1_DEC	Set decision height index
Master warn reset	AZP_JAGA_ALARMS_RESET_PRESSED	Reset alarms master warn
Indicator lights mode switch	AZP_JAGA_ALARMS_NIGHT_MODE_TOGGLE	Toggle day night mode for indicator lights
Alarms detection mode switch	AZP_JAGA_ALARMS_DETECTION_SWITCH_TEST AZP_JAGA_ALARMS_DETECTION_SWITCH_ON AZP_JAGA_ALARMS_DETECTION_SWITCH_MUTE	Set alarms detection mode switch
Alarms master switch	AZP_JAGA_ALARMS_MASTER_SWITCH_TOGGLE	Toggle alarms master

Name	H event	Description
		detection switch

MSFS 2024 specific

You will find in the section everything specific to the Jaguar for FS 2024 (native add-on).

This product adds interactive preflight actions and a weapons system specially tailored for the Jaguar.

Preflight actions

In Flight Simulator 2024, the flight will start on the apron at the exterior of the aircraft.

Before entering the aircraft, you need to click on ground equipment, to remove it before flight:

- Chocks.
- Engine intake covers.
- Pitot and static covers.



By walking around the aircraft, you can inspect various parts (struts, rudder, elevator, etc) and check their condition before flying. Each part to inspect or remove is indicated by a circled dot.



In order to inspect landing gear compartment, you can open GPU socket compartment and click on the switch located inside. This will open landing gear doors on both sides.



You can also achieve the same from the EFB.

Finally, in order to go inside the aircraft, you can walk in front of the ladder, and click on it, continuing to walk straight at the same time. You will climb the ladder and arrive in front of the cockpit.



Finally, click on the canopy frame to enter the aircraft.



You can also use a keyboard shortcut (default Maj + C) to go directly inside the cockpit.

From the EFB (first tab), you can remove the ladder and click on QUICK PREFLIGHT button to remove all covers and chocks. You will see warning texts if you forgot to remove them, and the engine will not start with intake covers on.

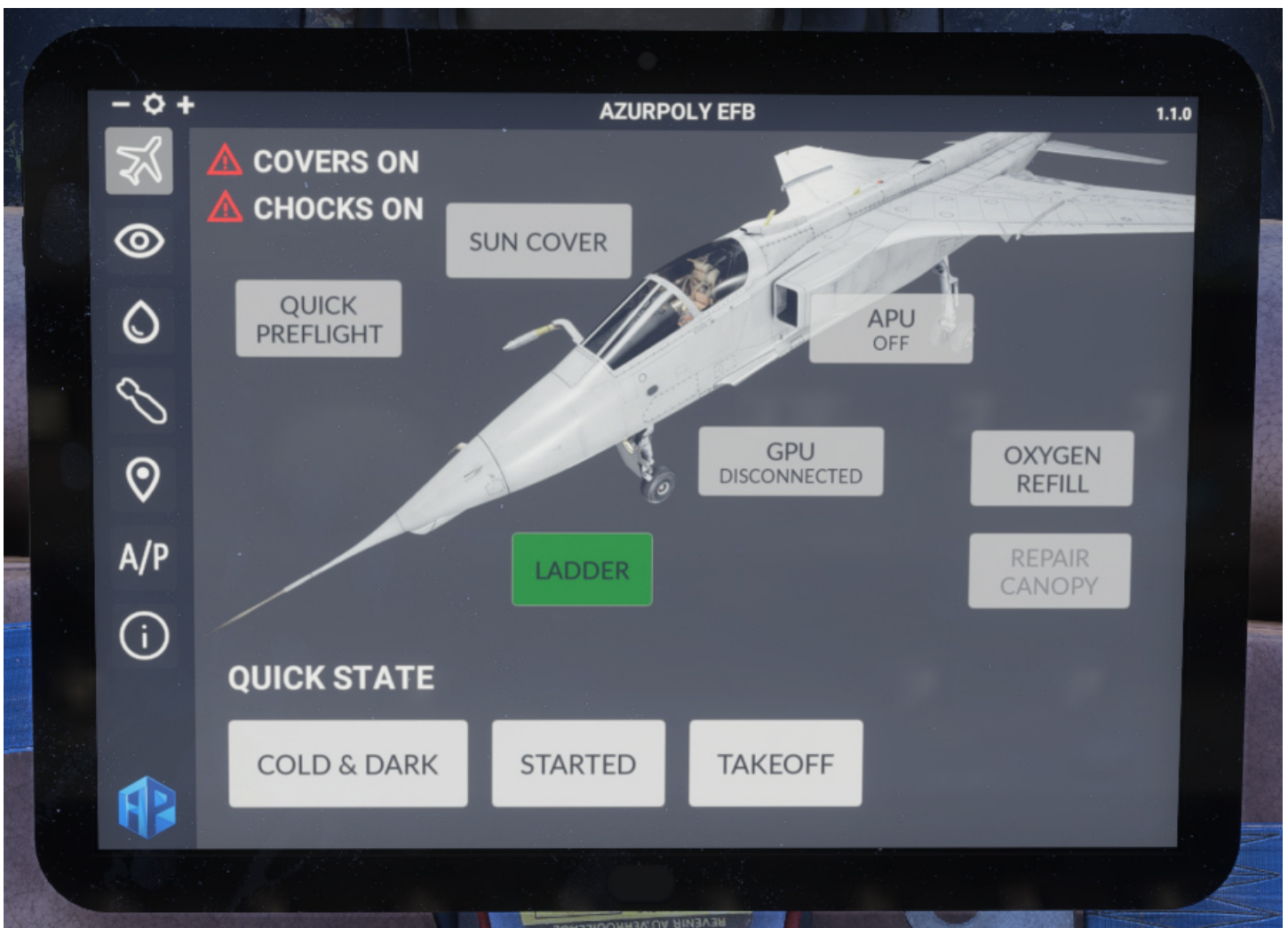

Weapons system

The Jaguar comes in MSFS 2024 with a custom weapons system, which includes missiles and bombs release, external fuel tanks jettison and a working cannon.

All weapons follow realistic trajectories, with smooth animations from the pylon to the impact zone, and accurate visual effects (at day and night) both in-flight and on impact.

! INFO

Our weapons system is purely visual and does not cause actual damage to the environment or other aircraft. Weapons are not shared in multiplayer and cannot aim real targets.

Enable weapons

Weapons can be used directly if you bought the product on third-party stores (Conrail, SimMarket).

If you purchased the aircraft on Microsoft Marketplace, weapons system is disabled by default as it is forbidden by Marketplace rules.

If you are on PC, you need to install a small patch that you can download on [our website](#) in order to enable the feature.

If you are on Xbox, weapons system cannot be used, unfortunately.

Weapons panel

To use the weapons, you first need to set weapons master knob to "WPN" (armed) position.



From any stage of the flight, you can add or remove external payload **from the EFB** that you wish to use.

In order to launch weapons and use the guns, a dedicated panel is located on right console.



#	Description	#	Description
1	Station 1 weapon selection button and lights	10	Bombs
2	Station 2 weapon selection button and lights	11	Guns safety switch
3	Station 3 weapon selection button and lights	12	Lights intensity switch (day/night)
4	Station 4 weapon selection button and lights	13	Panel lights test button
5	Station 5 weapon selection button and lights	14	Selective dropping mode switch
6	Guns (canon) ready light	15	Selective dropping button
7	Air/air missile safety switch	16	Intervalometer bombs quantity knob
8	Air/ground missile safety switch (INOP)	17	Intervalometer delay knob (INOP)
9	Rockets mode switch (INOP)	18	Bombs selection light

Air/ground weapons

In order to launch air/ground weapons (bombs), click on stations weapon selection buttons depending on the bombs you want to launch (in the example above, bombs are selected for stations 2 and 5).

Using the **HUD** in air/ground mode, you can visualize the expected impact point of the bomb. Please note that this is just an estimate, as the impact point can vary a lot depending on many factors (initial speed, wind, height, etc).

The "R" sign is displayed when a bomb drop is possible:

- Height above 50 feet.
- Indicated speed above 200 kts.
- Subsonic speed.
- Pitch and bank below 30 degrees.

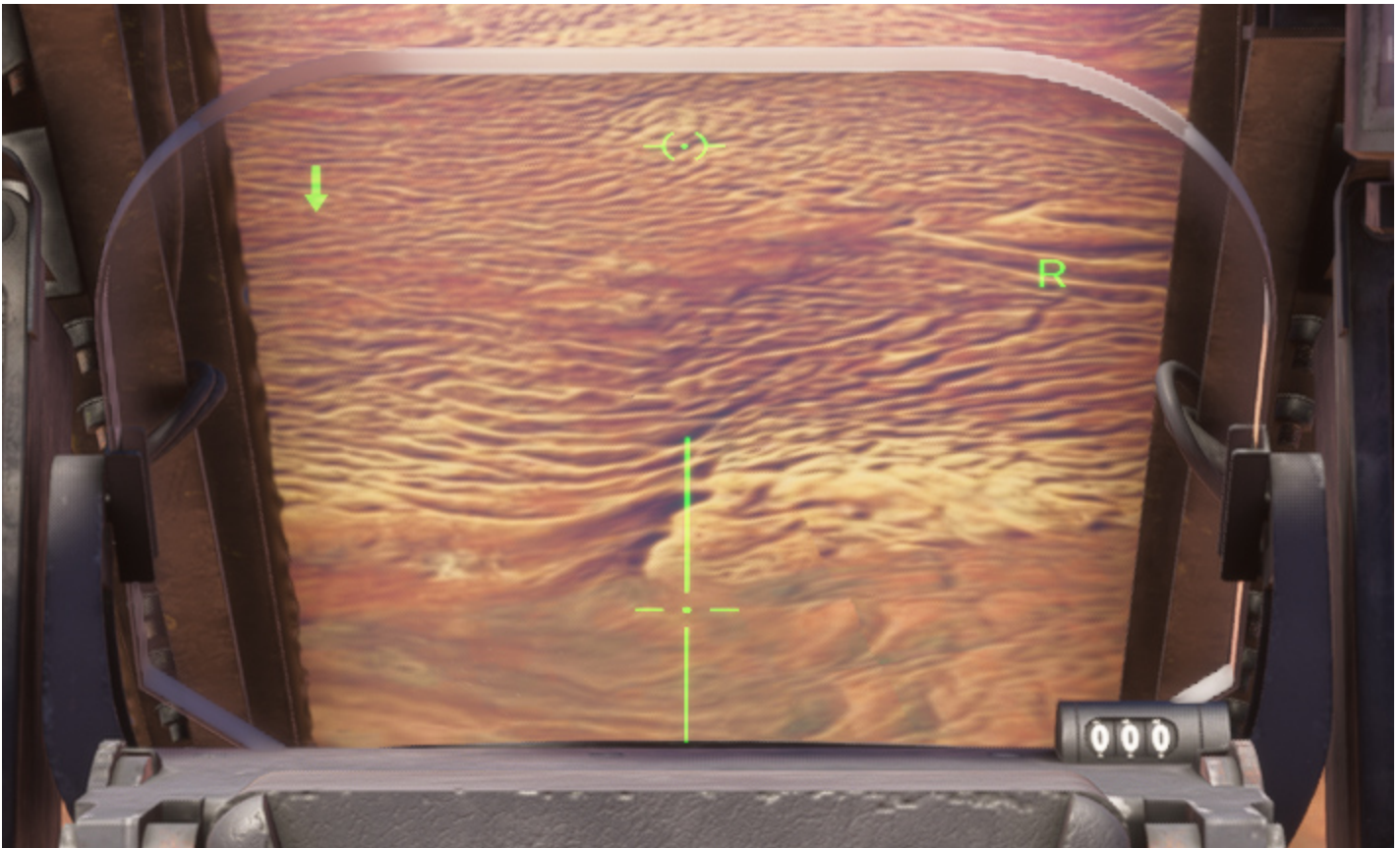

In order to trigger the launch, you need to assign a button to **TRIGGER HORN** event (in controls options).

At each click, a bomb is dropped approximately one second later, depending on what is selected on weapons panel, and the payload of the aircraft.

If you wish to drop several bombs at the same time, you can use the bombs quantity knob on intervalometer panel to select the quantity of bombs to drop. Please note that, because of software limitations, there is a 2 seconds delay between each object dropped.

Once the bomb reaches the ground, it will explode and a smoke column will remain above the impact point.



i NOTE

"AS37 Martel" weapon (Jaguar A) is considered as a bomb in the simulator, even though it is an air/ground missile in reality.

Air/air weapons

Our Jaguar can carry up to two air/air weapons: Magic missiles on the Jaguar A and AIM-9 Sidewinder missiles on the Jaguar GR1 (mounted on over-wing pylons).

First ensure that "AA" is selected on station 1 or 5 buttons (same with the Jaguar GR1 even though over-wing stations are not really 1 and 5).



Only one missile can be launched at a time, and you need to set the air/air missile safety switch to the desired position ("L" for left, "R" for right).

Missile launch is possible only if:

- Height is above 50 feet.
- Indicated airspeed is above 200 kts.

The same **TRIGGER HORN** event will launch the missile.



Guns

In order to use guns, guns safety switch needs to be moved to:

- Position 1 to fire a salvo.
- Position 2 to fire freely.

Please note that ammunition is infinite.

You can trigger the guns with **WAR EMERGENCY POWER** event binding.

Inert stores jettison

The Jaguar has different ways of jettisoning external stores in case of emergency, for example in case of engine failure after takeoff where the weight may need to be reduced drastically.

The first way is to use the black/yellow striped button above left console, that will drop all external stores (including fuel tanks and weapons). All weapons are jettisoned inertly (they will not explode once reaching the ground).



You can trigger an emergency stores release with **TOGGLE WING FOLD** event binding.

Even if it was not possible to drop external tanks independently in the real aircraft, you can do it from the EFB after selecting an external tank ("DROP TANK" button).



The other way is the selective dropping that you can trigger on weapons selection panel. Weapons that are selected on the panel will be jettisoned. External tanks are not jettisoned.

Selective dropping has two possible modes:

- Stores dropped one by one (EMER 1).
- Stores all dropped at the same time (EMER 2).

Selective dropping can be used only with master weapons armed. All weapons are jettisoned inertly.

Landing drag chute

The Jaguar had a drag chute fitted in order to reduce landing distances on small fields.

The parachute is fitted in the black cone just above engine nozzles.

In order to deploy it, parachute handle located above left console must be pulled. You can also use **AUTOBRAKE_HI_SET** (set autobrake high) binding with any of your controllers.



The chute will be deployed only once landing gear is in contact with the ground, and will drastically brake the aircraft thanks to its aerodynamic drag.



Once the aircraft has been slowed, pushing parachute handle will release it. The object will stay where it has been released.

