

# Table of contents:

## Manual changelog

- Revision 4 (04/03/2026)
- Revision 3 (17/10/2025)
- Revision 2 (27/08/2025)
- Revision 1 (20/08/2025)

## Introduction

- History
- Developer notes

## General description

- Specifications
- Detailed views
  - Front panel
  - Upper console
  - Upper console (top)
  - Centre console
  - Centre console (front)
  - Cockpit left
  - Cockpit right

## Engines and auxiliary power

- Engines
  - Description
  - Controls
    - Condition levers
    - Power levers
    - Idle levers
  - Methanol
- Auxiliary power
  - Turbo generator group
  - GPU
- Propeller
  - Description
  - Controls
  - Synchronization

## Electrical

- Description
- Batteries
- Generators
- Lights

- Exterior
- Interior
- Alarms
- De-icing
  - Probes and sensors
  - Windshield
  - Airframe
  - Engines & APU
- Wipers

#### Fuel system

- Tanks
- Pumps & valves
- Refill
- Transfer & dump

#### Hydraulics & controls

- Hydraulic generation
- Handling
  - Ailerons & spoilers
  - Elevator & rudder
  - Flaps
  - Spoilers
- Landing gear
  - Description
  - Controls
  - Steering
- Brakes
- Cargo loading & dropping
  - Exits
  - Lowering
  - Cargo
  - Dropping

#### Other systems

- Cabin environment and pressurization
  - Air conditioning
  - Pressurization
- Self-protection (flares)

#### Avionics

- EFIS
  - EADI
  - EHSI

- HSI mode
- ARC mode
- MAP mode
- Dynamic data display zone
- Display selector panel
- IRS
- FMS
  - Overview
  - INIT1 page
  - INIT2 page
  - DEPARTURE page
  - FLP1 page
  - FACILITY page
  - ARRIVAL page
  - FLP CHANGE page
  - FLP2 page
  - DIRECT TO page
  - COM page
  - NAV page
  - ALTITUDE page
- Autopilot
  - Horizontal
  - Vertical
  - Radio
- GPS
- HUD
- IFF / transponder
- Weather radar
- BDHI
- Ventilation
- Audio panel

#### Electronic flight bag

- Aircraft
- Payload
- Fuel
- Map
- Autopilot
- Information

#### Procedures

- Reference speeds

- Checklists
- Startup & shutdown

#### Performance

- Speed tables
- Takeoff
- Climb
- Cruise
- Descent
- Landing

#### Controls assignments

- Custom events

#### MSFS 2024 specific

- Preflight actions
- SimBrief integration
- Copilot display

# Manual changelog

## Revision 4 (04/03/2026)

- New documentation on Docusaurus.
- Added note in methanol section (**Methanol**).

## Revision 3 (17/10/2025)

- Added more details about pressurization (**Pressurization**).

## Revision 2 (27/08/2025)

Following native MSFS 2024 release:

- Added new section for specific FS2024 features (**MSFS 2024 specific**).
- Added possibility to use GTN 650 unit (**GPS**).
- Added screenshot of flares launch (**Self-protection (flares)**).
- Modified EFB section to spot FS2024 differences (**Electronic flight bag**).
- Added more details about troopers dropping (**Dropping**).

## Revision 1 (20/08/2025)

Following update 1.5.0:

- Added instructions to delete current flight plan (**FLP1 Page**).
- Added control binding to launch flares (**Self-protection (flares)**).
- Added description of new autopilot modes to follow NAV2 and TACAN (**Radio**).
- Added description for all lateral and vertical autopilot modes displayed on EADI (**EADI**).

# Introduction

## History

The Transall C-160 is a military transport aircraft, produced as a joint venture between France and Germany. Based on two turboprop engines on a high-mounted wing, it was designed to perform cargo and troop transport, aerial delivery of supplies and equipment.

C160 has been operated military by France and Germany during more than 50 years. It was also exported to South Africa and Turkey.

It is perfectly adapted to operations in short airfields, with the ability to perform steep descents and perform landings down to 400 meters long. As a cargo, it can carry up to 8.5 tons of material across a distance of 5.000 kilometers.

Our version is based on the C160R ("Rénové") which is the most modern version operated in France, with two additional fuel tanks, new avionics and refueling capabilities.

## Developer notes

This project would not have been possible without the help from MEAC (Musée Européen de l'Aviation de Chasse), that gave us access to a retired French Air Force C160. We deeply thank them for their warm welcome in Montélimar.

Huge thanks to Jonhatan "Max" Hilaire for helping us all along the project, and for lending his voice in our tutorial videos.

Thanks to the numerous beta testers who spotted the bugs and helped us improving our aircraft before the release.

The C160 has been a big challenge for our small team, given the complexity it represents. We release a version that we consider mature, but we have many ideas for future updates and several enhancements we plan to bring to all the systems, so please consider this as a living product.

### INFO

This manual covers both the Transall for MSFS 2020 and the native version for MSFS 2024. Both products share most of their features, hence we decided to write a single manual for them. For the features

specific to MSFS 2024, a section has been added at the end of the manual.

# General description

## Specifications

<b>Weights</b>	Empty weight	30,000 kg
	Maximum takeoff weight	51,000 kg
<b>Dimensions</b>	Wingspan	40 m
	Length	32.4 m
	Height	11.65 m
	Wing area	160 m <sup>2</sup>
	Cargo bay length	17.21 m
	Cargo bay area	54.25 m <sup>2</sup>
	Cargo capacity	139.9 m <sup>3</sup>
<b>Engines</b>	Type	Rolls-Royce Tyne 22
	Number	2
	Peak power	5,665 hp
	Maximum N1 speed	15,520 rpm
	Reduction ratio	1:16
	Compression ratio HP / LP	3.9:1 / 3.5:1
	Propeller diameter	5.48 m
	Fuel capacity	7,840 gal / 29,680 L / 23,830 kg
<b>Limits</b>	G-Force	+ 3 G / - 1.2 G
	Absolute ceiling	28,000 ft
	Never-exceed speed	320 kts

## Detailed views

You will find in this section the different parts of the cockpit with their respective functionalities.

If needed, you can enable tooltips in your simulator to get a description when hovering buttons, knobs and switches.

Please refer to next sections to get more detailed information about each system.

## Front panel



#	Description	#	Description
1	Magnetic compass	51	ITT indicator
2	Ice visual detector	52	Methanol valves & pressure indicators
3	Chronometer start/stop button	53	Fuel pressure & temperature indicator
4	Alarms panel (see <a href="#">alarms</a> )	54	Low fuel pressure light
5	Backlighting (left part) knob	55	Oil pressure & temperature indicator
6	Backlighting (central part) knob	56	Low oil pressure light
7	Backlighting (right part) knob	57	Gearbox low oil pressure & overheat lights
8	AOA indicator	58	<b>Weather radar</b>
9	Accelerometer	59	Left A & B tanks level indicator
10	Alternate static air switch	60	C tanks level indicator
11	Pitch reference knob	61	Right A & B tanks level indicator
12	Anemometer	62	Low fuel level lights

#	Description	#	Description
13	<b>BDHI</b> (pilot)	63	Fuel gauges & lights test
14	BDHI switches	64	Turbine bearing temperature indicator
15	Inclinometer	65	APU RPM indicator
16	<b>EADI</b> (pilot)	66	APU low pressure oil light
17	<b>EHSI</b> (pilot)	67	APU oil temperature indicator
18	IAS auto switch	68	APU nozzle temperature
19	Altitude alert light (pilot)	69	Blue/yellow hydraulic reservoir level
20	Warn/caution master lights	70	Green/red hydraulic reservoir level
21	Pitch/roll reset	71	Hydraulic reservoirs low level light
22	Trim failure lights	72	Blue hydraulic pressure indicator
23	IFF mode 4 light	73	Green hydraulic pressure indicator
24	Autopilot ground speed warn light	74	Blue/yellow hydraulic servo pressure
25	Clock	75	Green/red hydraulic servo pressure
26	Attitude indicator	76	Yellow hydraulic pump light
27	Altimeter	77	Yellow hydraulic pump switch
28	Ground altitude indicator	78	Red hydraulic pressure indicator
29	Variometer	79	Emergency brake hydraulic pressure indicator
30	EFB button	80	Landing gear not down light
31	EADI power/brightness knob (pilot)	81	Landing gear lever
32	EHSI power/brightness knob (pilot)	82	IFF mode 4 light
33	Neon lights panel (pilot)	83	Autopilot ground speed warn light
34	<b>Display selector panel</b> (pilot)	84	Trim failure lights
35	Landing gear crash switch	85	Clock
36	Fuselage lowering light	86	Spoilers indicator
37	Fuselage raising switch	87	Pitch reference knob
38	Landing gear not down light	88	Anemometer
39	Landing gear lever	89	Neon lights panel (copilot)

#	Description	#	Description
40	Landing gear state lights	90	EADI power/brightness knob (copilot)
41	Flaps indicator	91	EHSI power/brightness knob (copilot)
42	Flaps blockage light	92	<b>BDHI</b> (copilot)
43	Synchroscope	93	BDHI switches
44	Fuel burnt indicator & reset button	94	Display selector panel (copilot)
45	Torquemeter	95	<b>EADI</b> (copilot)
46	Automatic drag limitation system light	96	<b>EHSI</b> (copilot)
47	Low pressure rotor (N1) RPM	97	Altitude alert light (copilot)
48	Beta light	98	Altimeter
49	Roll trim indicator	99	Variometer
50	Rudder trim indicator	100	Alternate static air switch

## Upper console

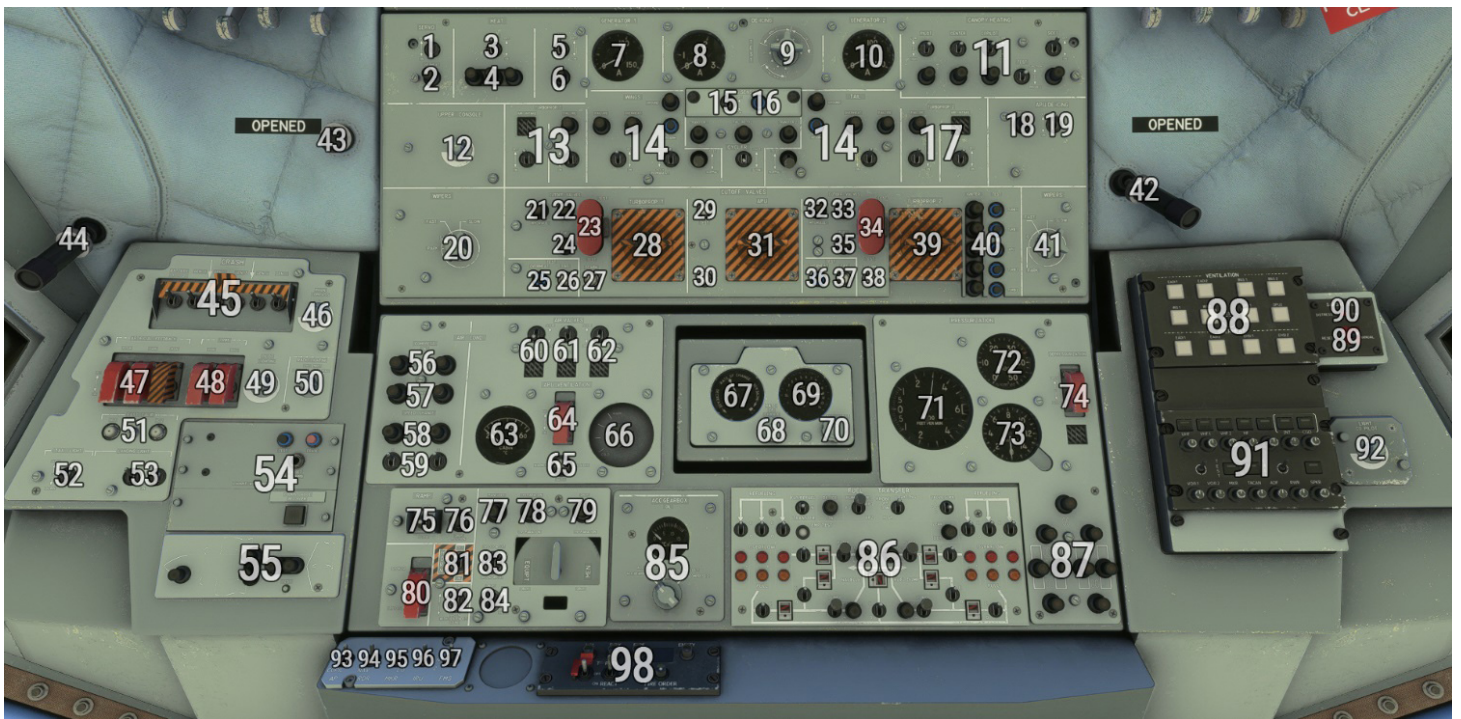

#	Description	#	Description
1	Servo commands heat switch	50	Radio lighting knob (not used)
2	Servo commands overheat light	51	Gyros fast calibration buttons

#	Description	#	Description
3	Pitot heat switch	52	Taxi light switch
4	Pitot heat not operating lights	53	Landing lights switches
5	Angle of attack sensor heat switch	54	Voice recorder panel
6	AoA sensor heat not operating light	55	Doors state lights
7	Generator 1 intensity indicator	56	Compressors oil overheat lights
8	Generator 2 intensity indicator	57	Compressors low oil pressure lights
9	Structural de-ice test intensity indicator	58	Compressors speed change lights
10	Structural de-ice test knob	59	Compressors transfer mode switches
11	<b>Windshield heating</b> panel	60	Left engine bleed air valve switch
12	Backlighting (top console) knob	61	APU bleed air valve switch
13	Left <b>engine de-icing</b> panel	62	Right engine bleed air valve switch
14	<b>Airframe heating</b> panel	63	Cabin air temperature indicator
15	Icing visual sensor light	64	APU ventilation fan isolation switch
16	Icing sensor heat button	65	Cabin air temperature manual selection
17	Right engine de-icing panel	66	Cabin air temperature knob
18	APU de-icing failure light	67	Pressurization target rate of change indicator
19	APU de-icing switch	68	Pressurization target rate of change knob
20	Wiper knob (pilot)	69	Pressurization target altitude indicator
21	Left hydraulic shut-off valve 1 light	70	Pressurization target altitude knob
22	Left hydraulic shut-off valve 2 light	71	Pressurization rate of change indicator
23	Left shut-off valves test buttons	72	Cabin differential pressure indicator
24	Left fuel shut-off valve light	73	Pressurization altitude indicator
25	Left engine overheat test button	74	Depressurization valve switch
26	Left engine fire test button	75	Ramp open/close switch
27	Left fuel shut-off valve rearm button	76	Stoker dropping position light
28	Left engine fire shut-off handle	77	Ramp maneuver allowed light
29	APU fuel shut-off valve test button	78	Ramp preparation light

#	Description	#	Description
30	APU fuel shut-off valve rearm button	79	Ramp dropping light
31	APU fire shut-off handle	80	Cargo pilot/stoker command switch
32	Right hydraulic shut-off valve 1 light	81	Cargo horn switch
33	Right hydraulic shut-off valve 2 light	82	Doors signal mode switch
34	Right shut-off valves test buttons	83	Doors hydraulic circuit priority switch
35	Right fuel shut-off valve light	84	Dropping pilot/navigator switch
36	Right engine overheat test button	85	Compressors & gearboxes oil temperature panel
37	Right engine fire test button	86	Fuel <b>refill</b> & <b>transfer</b> panel
38	Right fuel shut-off valve rearm button	87	Landing gear hatches state lights
39	Right engine fire shut-off handle	88	<b>Avionics ventilation</b> state panel
40	Extinguishers igniters test buttons	89	ELT mode switch
41	Wiper knob (copilot)	90	ELT active light
42	Copilot lamp	91	Audio panel (flight engineer)
43	Engineer lamp	92	Copilot lamp knob
44	Pilot lamp	93	Autopilot control priority switch
45	Emergency batteries & generators disconnection switches	94	NAV mode (GPS/VLOC) switch
46	Magnetic compass light knob	95	Marker sensitivity switch
47	Artificial feedback disconnection switches	96	Inertial reference unit source switch
48	Electrical trim disconnection switches	97	Flight management system source switch
49	Pilot lamp knob	98	<b>Flares launch</b> panel

## Upper console (top)

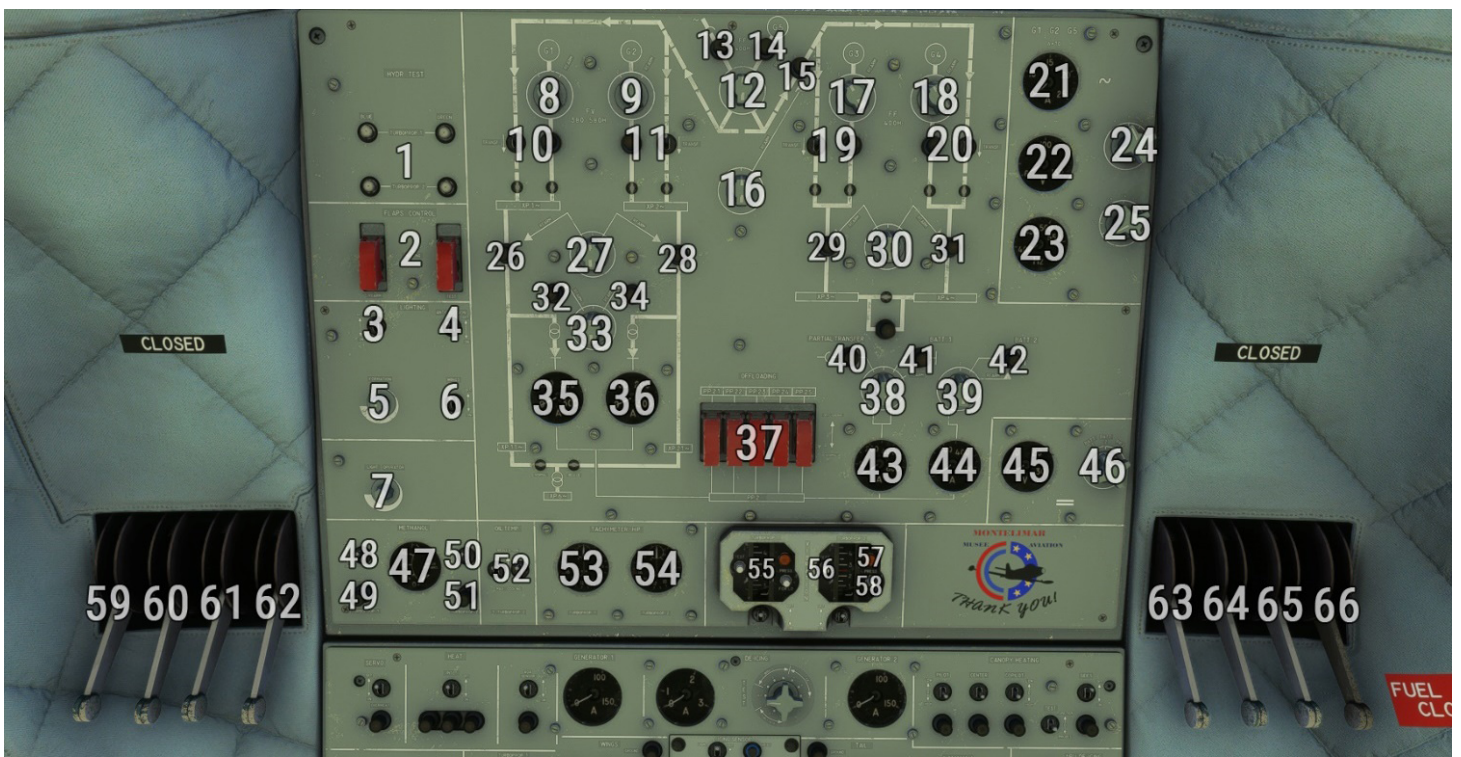

#	Description	#	Description
1	Engines hydraulic test buttons	34	Transfo-rectifier 2 (TR2) failure light
2	Flaps torsion test buttons	35	Transfo-rectifier 1 intensity indicator
3	Navigation lights switch	36	Transfo-rectifier 2 intensity indicator
4	Anticollision (beacon) lights switch	37	PP2 offloading switches
5	Formation lights knob	38	Battery 1 knob
6	Wing lights switch	39	Battery 2 knob
7	Flight engineer lamp knob	40	GPU transfer light
8	Generator 1 (G1) knob	41	Battery 1 failure light
9	Generator 2 (G2) knob	42	Battery 2 failure light
10	G1 to XP1 transfer switch	43	Source 1 intensity indicator
11	G2 to XP2 transfer switch	44	Source 2 intensity indicator
12	Generator 5 (G5) knob	45	Direct current source voltage indicator
13	GPU available light	46	Direct current source voltage visualization knob
14	Generator 5 active light	47	Water-methanol level indicator
15	Generator 5 failure light	48	Left water-methanol system switch

#	Description	#	Description
16	External electrical source rearm knob	49	Left water-methanol pump operation light
17	Generator 3 (G3) knob	50	Right water-methanol system switch
18	Generator 4 (G4) knob	51	Right water-methanol pump operation light
19	G1 to XP3 transfer switch	52	Engine oil temperature regulation switches
20	G1 to XP4 transfer switch	53	Left engine high pressure rotor (N2) RPM
21	Generator intensity indicator	54	Right engine high pressure rotor (N2) RPM
22	Generator voltage indicator	55	Engine vibration indicator
23	Generator frequency indicator	56	Engine vibration indicator test button
24	Generator parameters visualization phase selection knob	57	Engine vibration high level light
25	Generator parameters visualization selection knob	58	Engine vibration low frequencies mode
26	XP1 failure light	59	APU fuel valve handle
27	XP1/XP2 rearm knob	60	Inter left fuel valve handle
28	XP2 failure light	61	Left tank B fuel valve handle
29	XP3 failure light	62	Left tank A fuel valve handle
30	XP3/XP4 rearm knob	63	Right tank A fuel valve handle
31	XP4 failure light	64	Right tank B fuel valve handle
32	Transfo-rectifier 1 (TR1) failure light	65	Inter right fuel valve handle
33	TR1/TR2 rearm knob	66	Fuel dump valve handle

## Centre console

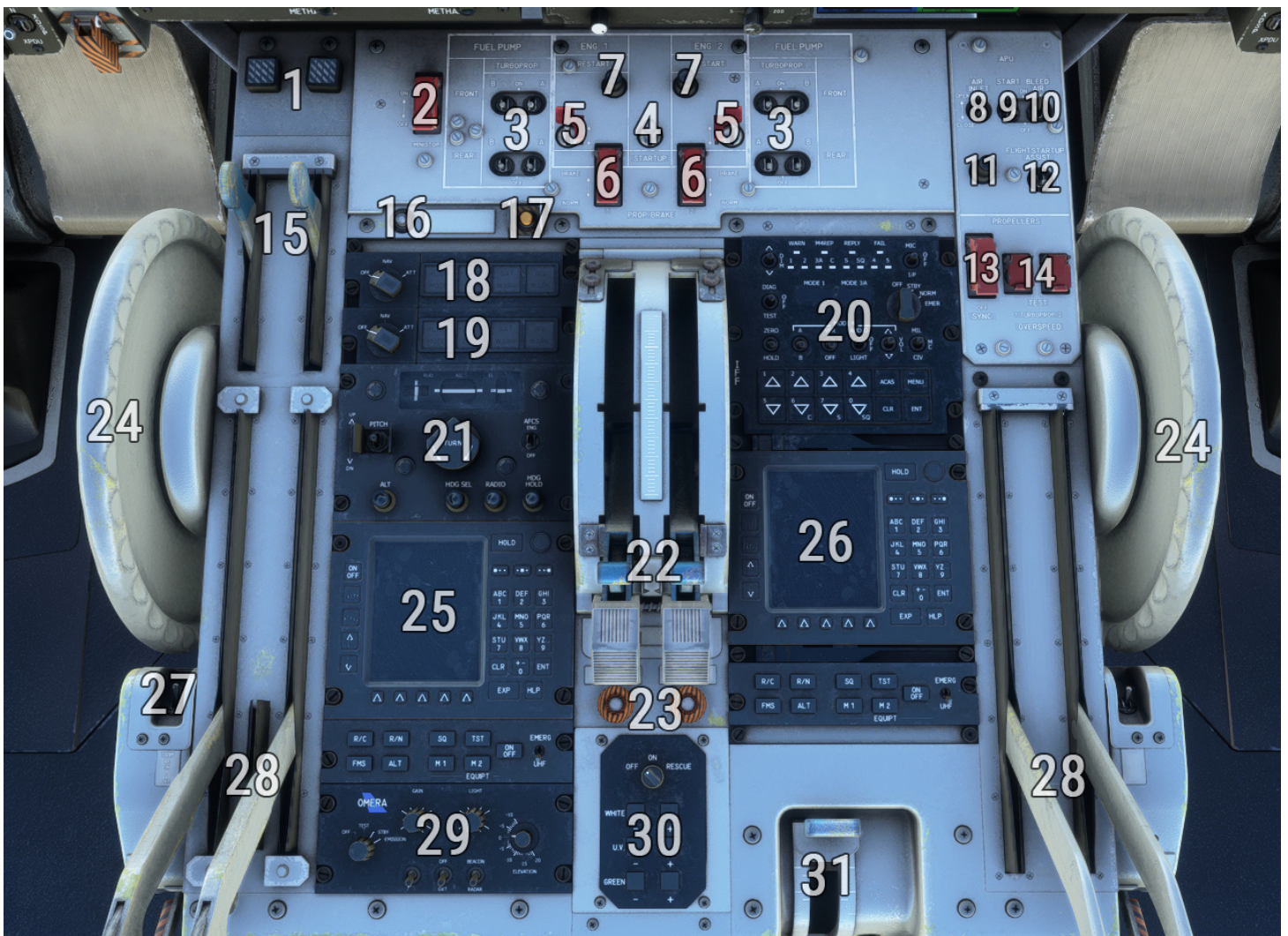

#	Description	#	Description
1	Idle levers magnetic indicators	17	Centralized control system test button
2	Brakes mini-stop (anti-skid) switch	18	<b>Inertial Reference System (IRS)</b> 1 panel
3	Fuel pumps switches	19	Inertial Reference System (IRS) 2 panel
4	General engine start switch	20	<b>Identification Friend or Foe (IFF)</b> panel
5	Left/right engine start switches	21	Autopilot panel
6	Propeller brake switches	22	Condition levers
7	Engine starter light	23	Feather electrical motors
8	APU air inlet switch	24	Pitch trim wheel
9	APU starter switch	25	<b>Flight Management System (FMS)</b> (pilot)
10	APU bleed air switch	26	Flight Management System (FMS) (copilot)
11	APU air inlet opened light	27	Pitch trim autopilot link switch

#	Description	#	Description
12	APU in-flight start help switch	28	Power levers
13	Propeller synchronization switch	29	Weather radar commands panel
14	Propeller overspeed test buttons	30	Neon lights panel (center console)
15	Idle levers	31	Flaps lever
16	IRS test button		

## Centre console (front)

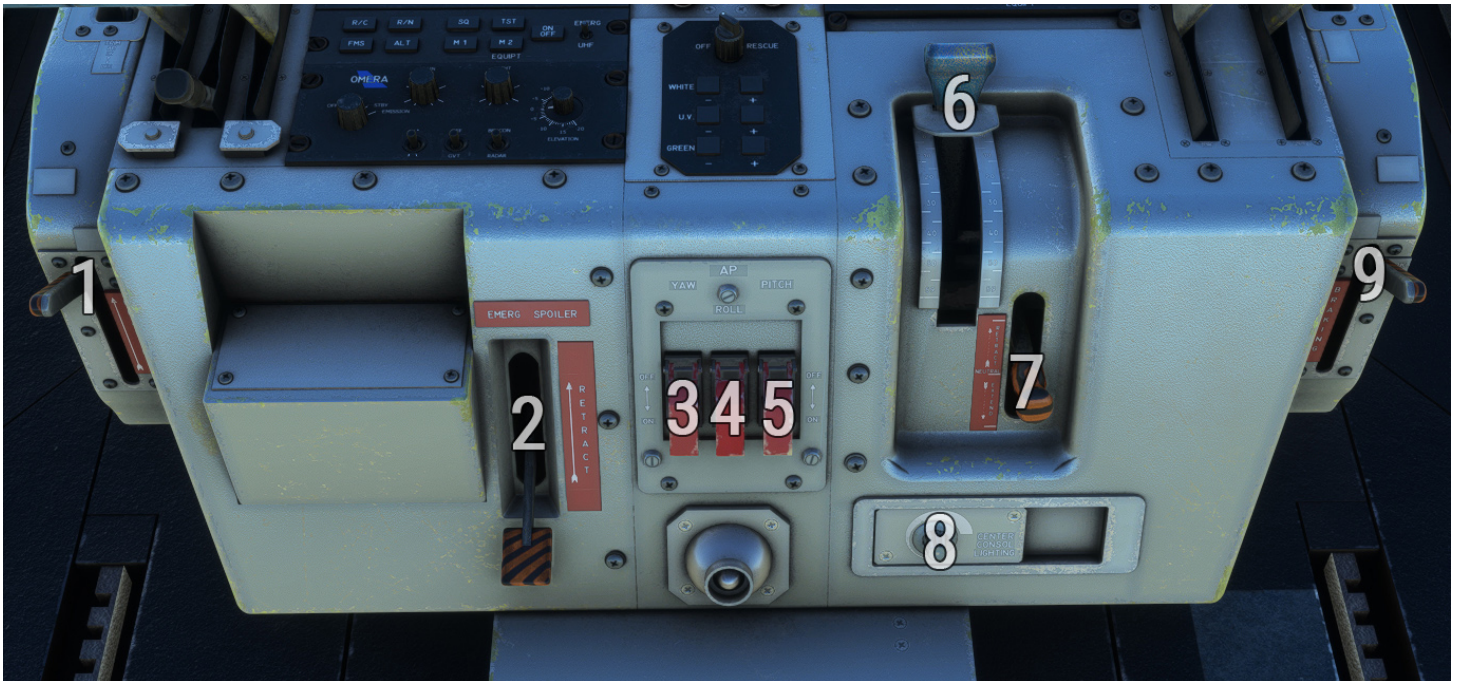

#	Description	#	Description
1	Emergency brakes lever	6	Flaps lever
2	Emergency spoilers retract lever	7	Emergency flaps lever
3	Autopilot yaw servo disconnect switch	8	Backlighting (center console) knob
4	Autopilot roll servo disconnect switch	9	Parking brake lever
5	Autopilot pitch servo disconnect switch		

## Cockpit left



#	Description	#	Description
1	Spotlights switch	3	Window handle
2	Audio panel (pilot)	4	Steering tiller link switch

## Cockpit right



#	Description	#	Description
1	Window handle	2	Audio panel (copilot)

# Engines and auxiliary power

## Engines

### Description

The aircraft is powered by two Rolls Royce "Tyne 22" turboprop engines, providing maximum 5,665 HP (ISA conditions) with 510 kilograms of residual thrust.

This turboprop is twin-spool with:

- Axial compressor with six-stage LP and nine-stage HP.
- Turbine with three-stage LP and single-stage HP.

Each engine is connected to:

- Two electrical generators.
- Two hydraulic pumps.
- An accessory drive for accessories and bleed air generation.

### Controls

Main engine controls are located in the central console.

In the real aircraft, more settings are available (for example separate "on ground" and "in flight" zones for the power lever) but were simplified for usability purpose within the simulator.

### Condition levers



Condition levers control fuel mixture with three distinct zones:

- Lower position: fuel cut-off.
- Middle position: low idle (minimum fuel mixture).
- High position: high idle (maximum fuel mixture).

The embedded Fuel Control Unit (FCU) can manage auto-mixture depending on aircraft speed, altitude and requested power (from power levers).

Condition levers can be bound to physical controllers using the following bindings:

- Condition lever cutoff/low idle/high idle to switch between the three lever positions.

**CONDITION LEVER 1 LOW IDLE**

**CONDITION LEVER 1 HIGH IDLE**

**CONDITION LEVER 1 CUT OFF**

- Mixture axis to set lever more precisely between middle and high positions.

**MIXTURE 1 AXIS (0 TO 100%)**

## Power levers



Power levers control both FCU and Propeller Control Unit (PCU) and have two zones:

- From 20° to 70°: Proportional forward thrust request.
- From 20° to 0°: Proportional reverse thrust request.

## Idle levers



Idle lever purpose is to control fuel injection during engine startup. They have two positions:

- A start position (“STRT”) controlling the “start idle” valve for the engine to reach appropriate N1 RPM.
- A normal position (“NORM”) once engine is started.

A dedicated magnetic indicator is located above each lever to see its current position.

## Methanol

Take-off performance of the “Tyne” engine decreases from 1% per degrees above I.S.A conditions. A water-methanol circuit can be enabled during takeoff to ensure maximum performance.

### ! INFO

Methanol injection system has been simulated but will not bring any performance increase as the simulator does not allow to implement this specific behavior. It is only available for immersion and roleplay purposes.

Methanol is injected in first stage of low-pressure compressor, thus decreasing air temperature and allowing to inject more fuel.

Two pumps allow a flow of 2225 liters per hour at 1.5 bars. Total capacity is 325 liters, allowing around 10 minutes of injection.

On top console:

- One gauge with total methanol level.
- Two switches to turn on pumps.
- One light per pump to show its operation.



Once pumps are running, injection will start only if condition levers are fully forward and if engine torque is above 75 PSI.

On front panel:

- One light per engine lighting up when methanol injection pressure is above 0.62 bars.
- One magnetic indicator per engine showing "OPEN" once injection valve is opened.



Methanol level is also displayed on the EFB, with a button to refill:

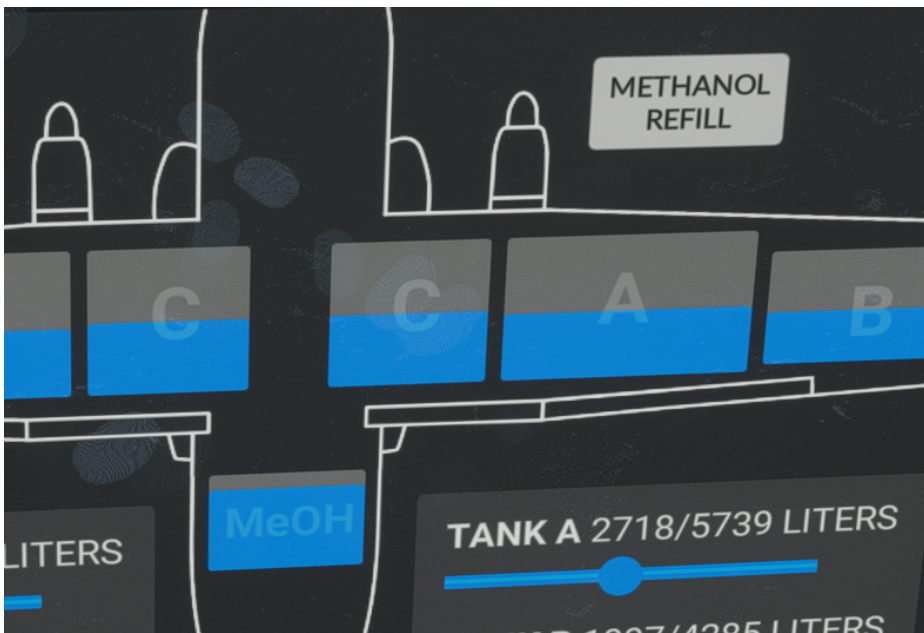

## Auxiliary power

### Turbo generator group

Turbo generator group is located in front of left landing gear. It is slightly different as a typical APU (auxiliary power unit) as it does not only generate electricity and bleed air, but also hydraulic power (on the red hydraulic circuit). It is composed of a AirResearch turbine, rated 200 HP.

The connected generator is G5, rated 60 kVA, allowing electrical supply when both engines are off. Bleed air for engine start and air conditioning is generated with a flow of 0.905 kilograms per second.

APU is self-regulated and does not need any manual action when running. It can be monitored through its dedicated front panel section with:

- %RPM gauge.
- Oil temperature gauge.
- Exhaust gas temperature gauge.
- Low oil pressure light when pressure is below 0.1 bars.



APU commands are gathered on center console:

- Air inlet switch.
- Starter switch.
- Bleed air switch.
- Flight startup switch.



Air inlet needs to be opened prior to starting the APU as it allows air supply. Starter switch will trigger an automatic sequence after which APU will reach and maintain 100% RPM.

Closing air inlet will automatically shut the APU down.

## GPU

A ground power unit can be connected to the Transall to provide direct current, when the battery is on but not being recharged by the APU generator.

The real aircraft can also be supplied with alternating current, but both are managed with the same unit within the simulator. See **electrical section** for more information.

Power unit can be connected via the EFB:



Transfer to main electrical source is done from upper console:



# Propeller

## Description

Each engine is equipped with a four-bladed constant speed propeller, with a diameter of 5.486 m. The model on the later versions of the Transall is "Ratier Figeac FH152-2", built with composite materials instead of metal on previous versions.

Each blade covers an angle of 100° from minimum to maximum pitch, allowing a "reverse" mode to land on small distances. Engine lubricant is used as hydraulic fluid for propeller pitch changes, with a safety edge in case of oil pressure drop.

## Controls

Propeller is controlled automatically depending on power lever input. To cover engine power loss scenarios in flight and avoid excessive drag, it will be feathered in two cases:

- Condition lever in cut-off position.
- Fire shut-off valve closed (upper console).

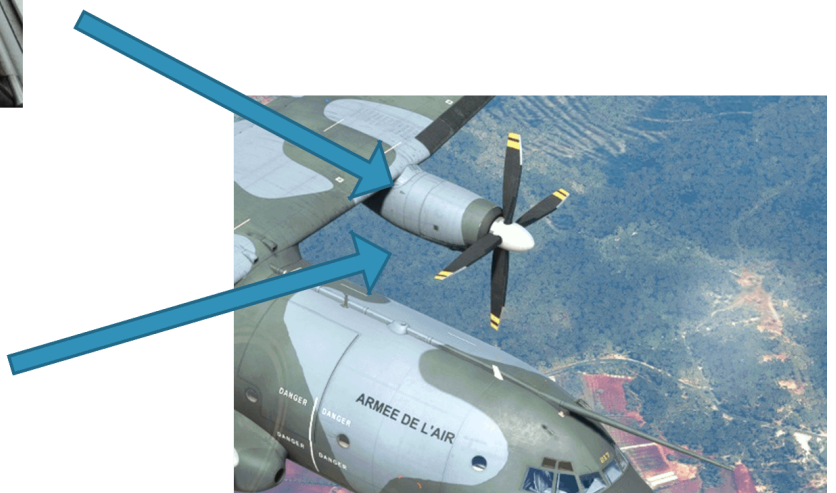
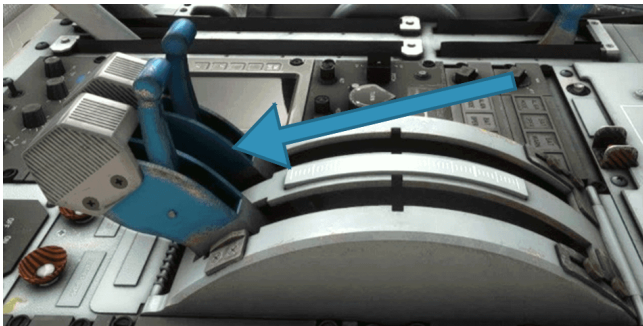

While on-ground with engines off, an electrical motor can be used to put propeller in feather position:



## Synchronization

Right engine propeller speed can be synchronized with left engine propeller to decrease noise and vibrations while in cruise.

System is enabled with a switch on the center console, and will work as soon as speed difference is not too important (below 150 RPM).



A synchroscope allows to see rotation speed differences between two engines. Right engine propeller rotates faster than left engine propeller if the needle rotates clockwise, and slower if counterclockwise.

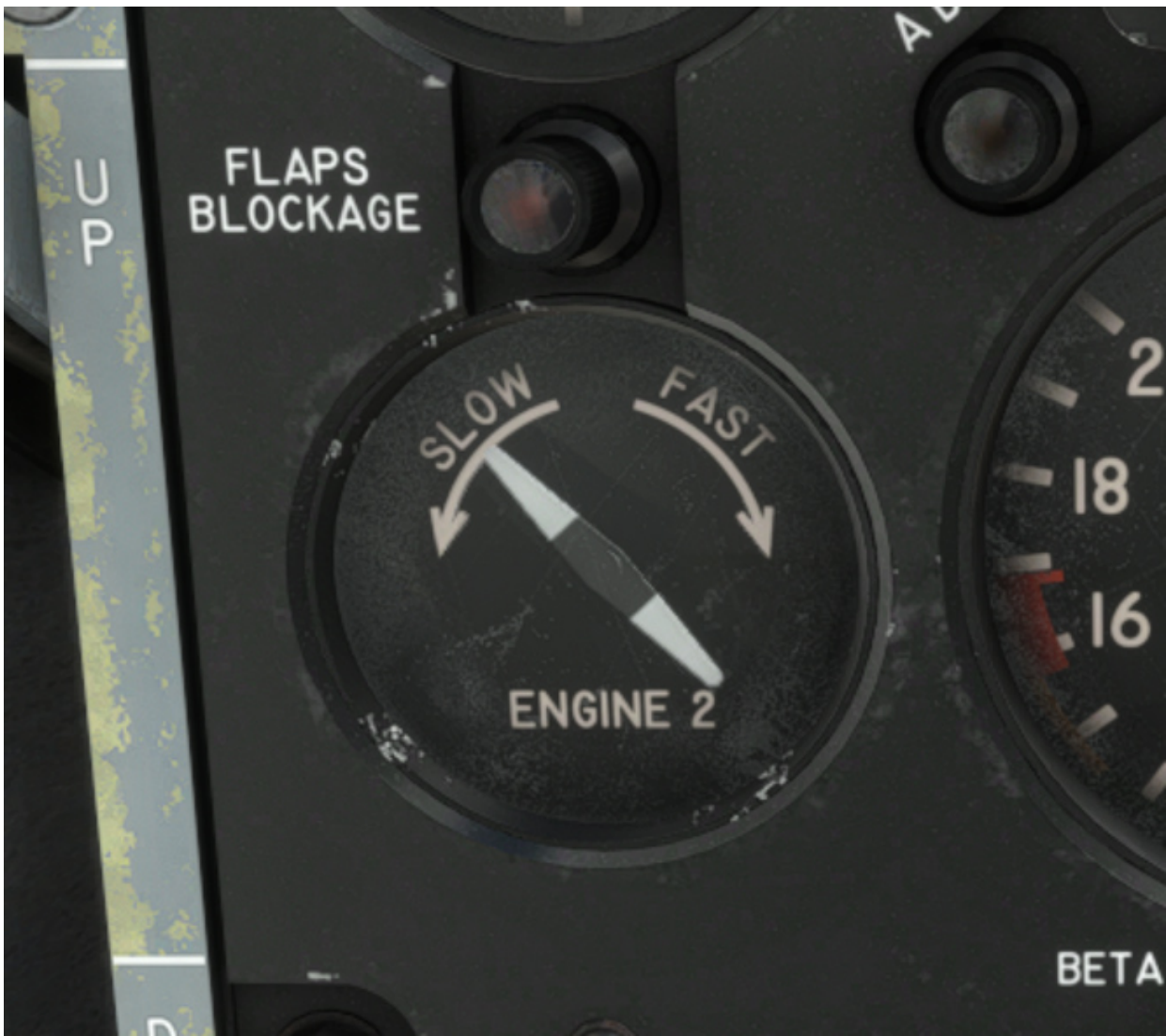

# Electrical

## Description

Electrical installation consists of:

- Two independent three-phase circuits (115V and variable frequency 380~580Hz), named **XP1** and **XP2**, each powered by a 60kVA generator (named **G1** & **G2**).
- Two independent three-phase circuits (115V and fixed frequency 400Hz), named **XP3** and **XP4**, each powered by a 9kVA generator (named **G3** & **G4**).
- One 28V DC (direct current) circuit, named **PP2**, and powered by **G1** and **G2** generators, via two 6kW transformer-rectifiers (named **TR1** and **TR2**). Two 40Ah batteries are connected to this circuit. As described in GPU, a ground power unit can also be used to supply this circuit.

Everything related to electrical network is managed from the top part of the upper panel, including:

- Batteries switches.
- Generators switches.
- Visualization of intensity, voltage and frequency for each generator.
- Visualization of intensity and voltage for batteries and transformer-rectifiers.

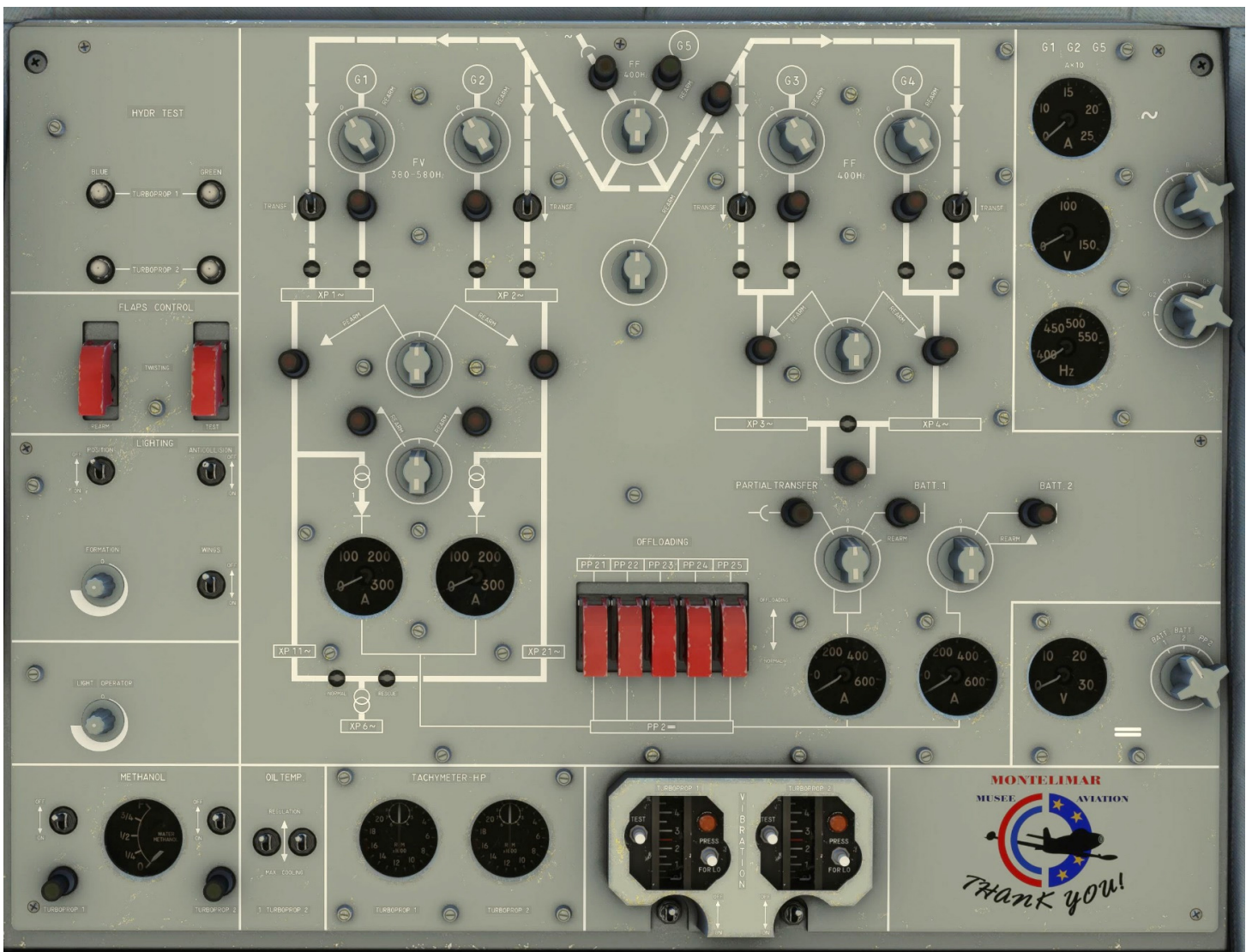

## Batteries

Two batteries provide electrical power while engines are stopped. They have a limited capacity of 40Ah each and can power basic elements such as APU starter, ventilation, interior lighting, etc.

They can be connected or disconnected from the DC network using their dedicated selector.

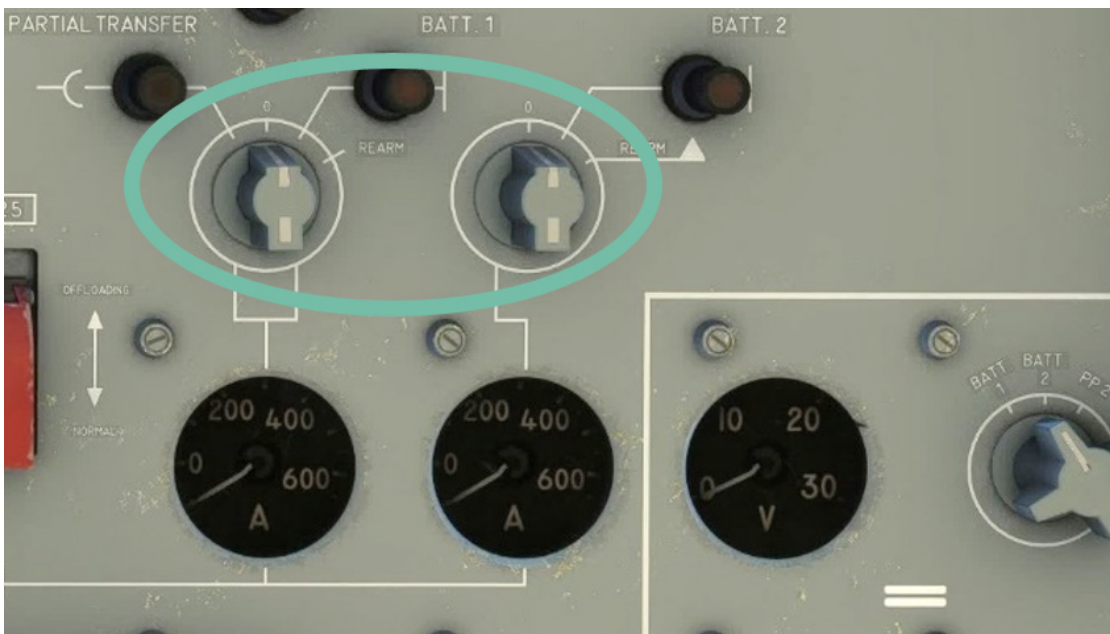

They can be monitored thanks to:

- A load gauge graduated from 50A to 600A.
- A voltage gauge graduated from 0V to 30V.

Nominal voltage is 25.5V. A red light indicates a low capacity for the battery.

## Generators

Each engine ships a 60kVA generator (**G1** for left engine, **G2** for right engine) and a 9kVA generator (**G3** for left engine, **G4** for right engine), to guarantee redundancy.

A fifth generator named **G5**, connected to the APU, can power each three-phase circuit.

They all can be connected or disconnected from their network using the dedicated knob.

They can be monitored independently using gauges on the right side of the panel.

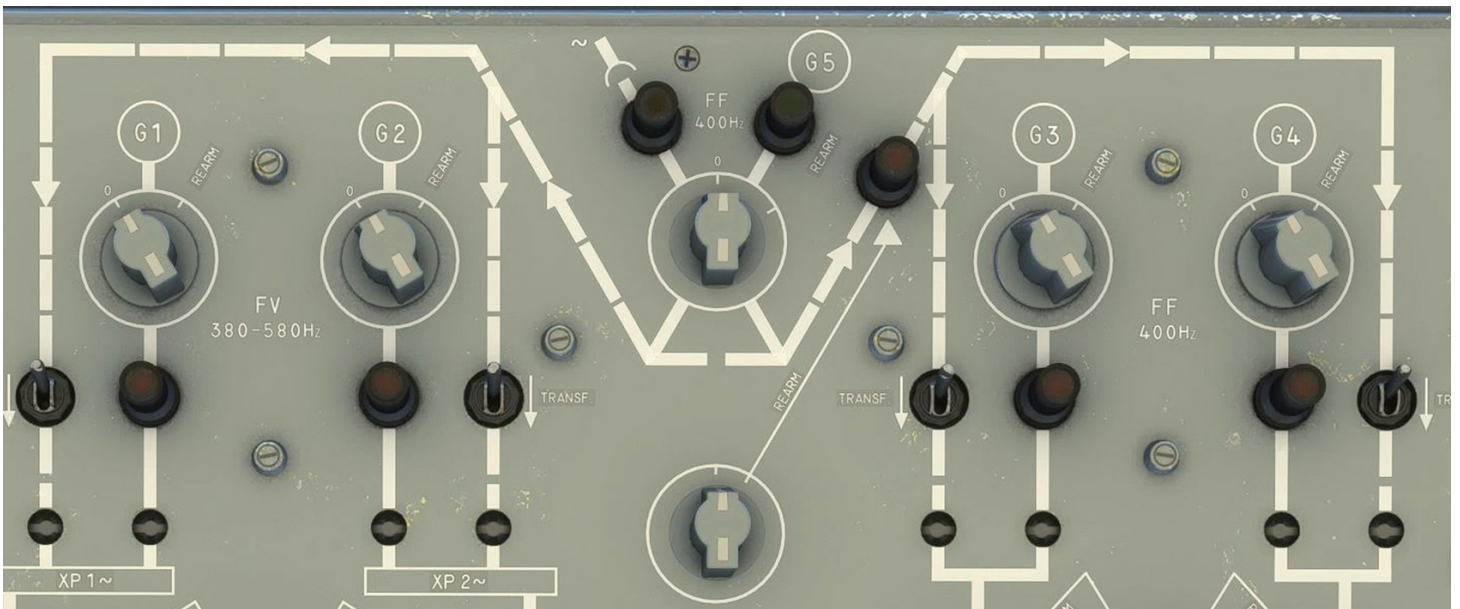

When APU nominal RPM value is reached, G5 generator is available. In this case it can be selected using GPU/G5 selector knob. A green light turns on when G5 is selected.



On each generator circuit, a red light indicates either a failure or a loss of power.

When all four engine generators are off and only APU (or GPU) is running, transfer switches must be set to ON (switch forward). They insure connection between APU/GPU circuit and other generators circuits.

In normal conditions, no red light should be on.

## Lights

# Exterior

All exterior lights are managed on top console:

- Taxi lights.
- Landing lights (x2).
- Position / navigation lights.
- Anticollision (beacon).
- Formation lights.
- Wing lights.
- Refueling probe light.



# Interior

A lot of interior lights are available in the Transall. You will find knobs and switches for interior lights in several places of the cockpit. Some lights have been enhanced compared to the real aircraft (e.g. backlighting) to ensure a good readability of all the instruments by night.

The interior lighting is composed of:

- One lamp for each cabin crew (pilot, copilot, engineer, navigator).
- Three neon lights on the front panel.
- Panel backlighting.
- A dome light.
- Two spotlights on the sides.
- Magnetic compass light.

For each panel, **backlighting** intensity can be set with a knob.



You will also find command panels for **neon lights**. Each panel allows to choose intensity of white, green and UV neon in their associated zone.



On ground or when cruising, cabin can be illuminated by two sides **spotlights**.

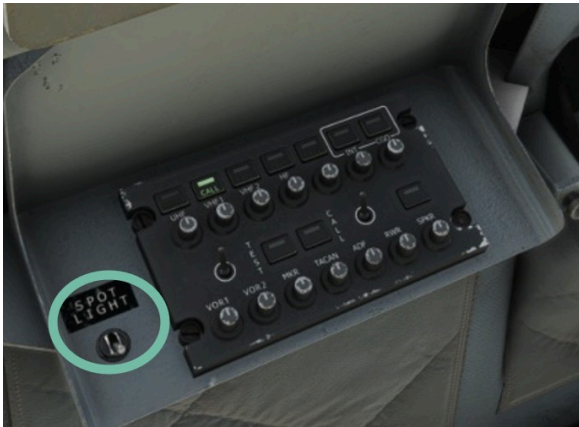

There is another lower intensity **dome light** on cabin ceiling that can be switched by clicking on it.



Cargo bay can be illuminated as well from the **tablet** (EFB).

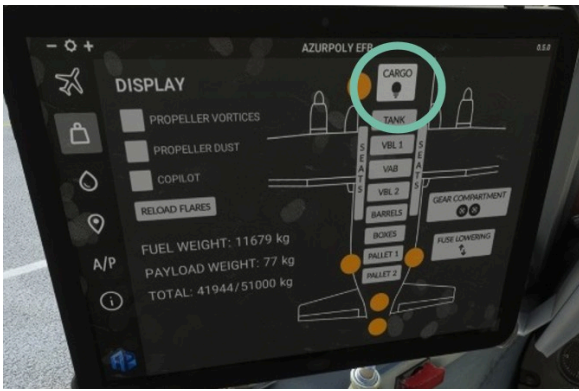

## Alarms

All alarms are gathered in a long panel shared between pilot and copilot, on top of front panel.



Two severity levels are considered:

- **CAUTION**, orange color.
- **WARNING**, red color.

Each time an alarm is raised by the system, main caution or warn light will be illuminated and the corresponding alarm will be displayed in the grid.

Each red alarm will generate a continuous beep tone that can be stopped by pressing the pad.

ENG DFR 1	COMPRESS 1	GENERATOR 1	ARTHUR YAW	APU FIRE
Engine 1 defrost failure	Engine 1 compressor oil overheat (> 120 °C) or	Generator 1 failure	Artificial feedback failure (yaw)	APU fire

	low pressure (< 3.35 bars)			
P OIL ENG 1	ACC GRBX 1	GENERATOR 3	ARTHUR PITCH	OVRHT ENG 1
Engine 1 low oil pressure (< 2.06 bars)	Engine 1 gearbox oil overheat (> 120 °C) or low pressure (< 3.35 bars)	Generator 3 failure	Artificial feedback failure (pitch)	Engine 1 overheat (breather circuit > 180 °C)
VIBRATIONS	GENERATOR 5	T R U	AUTO PILOT	FIRE ENG 1
High engine vibrations (>2.5)	Generator 5 failure	Transformer-rectifier unit failure	Autopilot disconnection	Engine 1 fire

HYD PRESS	HYD RES	CYCLERS	GENERATOR 2	COMPRESS 2	ENG DFR 2
Blue/green hydraulic low pressure (< 122.6 bars)	Blue/green hydraulic reservoir low level	Heating cyclers failure	Generator 2 failure	Engine 2 compressor oil overheat (> 120 °C) or low pressure (< 3.35 bars)	Engine 2 defrost failure
OVRHT ENG 2	CABIN ALT	WINGS DE-ICE	GENERATOR 4	ACC GRBX 2	P OIL ENG 2
Engine 2 overheat (breather circuit > 180 °C)	Loss of cabin pressure Cabin alt > 11700ft	Wings de-ice failure	Generator 4 failure	Engine 2 gearbox oil overheat (> 120 °C) or low pressure (< 3.35 bars)	Engine 2 low oil pressure (< 2.06 bars)
FIRE ENG 2	DIFF ALT	TAIL DE-ICE	BATTERIES	SERVO BL	VENTILATION
Engine 2 fire	High differential pressure (> 335 gr/cm <sup>2</sup> )	Tail de-ice failure	Battery disconnection	Commands blocking authorization if blue pressure < 80 bars	Ventilation failure

## De-icing

Complex de-icing systems are operated to fly in icing conditions.

De-icing installation ensures the protection of:

- Airframe (wings and tail).
- Engines and APU.
- Pitot tubes and AOA probe.
- Windshield.
- Servo commands.

Those systems are all controlled from the upper console.

## Probes and sensors

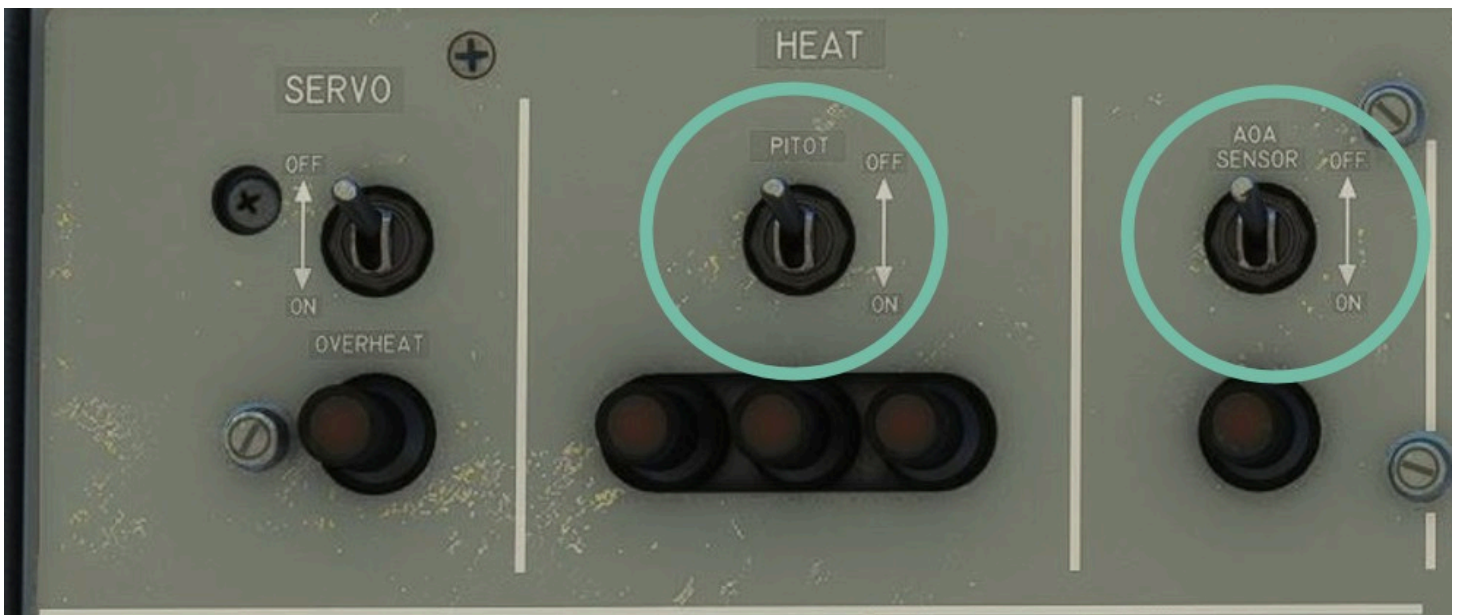

During any flight, pitot tubes and angle of attack sensor heating should be functioning.

To assess icing intensity while flying in icing conditions, a luminous tube is located in front of the windshield.

It can normally be heated up in order for the crew to visualize the speed of ice formation on it. This functionality is not simulated for now because of technical limitations. However, the tube can be lighted from the de-icing panel.



## Windshield



Windshield heating is divided in four zones (pilot, center, copilot and sides). Two heat intensities can be set depending on the severity of icing conditions.

Each zone has a light which is on when heating is not functioning.

## Airframe

Both wings and tail share the same de-icing technology located on the leading edges, with several zones being electrically heated.

Two types of heating are available: permanent heating (continuous) and cycled heating. A switch allows to switch between those different modes.

Heating circuits are protected and monitored. For both wings and tail de-icing, red lights indicate:

- System failure.
- Overheat.
- Active de-icing while aircraft is on ground (which should be avoided).



Heated zones are very distinctive in the exterior model as they are made of black nitrile for corrosion protection:



# Engines & APU



Engines and APU de-icing is achieved by three different manners:

- Electrical heating.
- Hot air.
- Hot oil.

APU air inlet periphery is electrically heated, and hot air is extracted from the APU compressor to heat the air inlet zone as well.



Regarding engines:

- Air intake crown is electrically heated.
- Hot air extracted from high pressure compressor is released on first stage of compressor blades, around air intake and oil radiator entry.
- Engine oil is circulating around air intake, effective once the engine is running.

Propeller de-icing works the same way as airframe de-icing but only with cycled heating.

Propeller cone and blade root only are heated.



## Wipers

Two wipers (pilot and copilot side) are used to evacuate rain on the windshield.



A knob on each side of upper console controls wipers:

- SLOW and FAST positions to turn the wiper on with two possible speeds.
- 0 position to stop the wiper.
- PARK position is unstable and will let the wiper go to his initial position, before being switched off.



# Fuel system

## Tanks

First Transall versions used to carry only two tanks per wing, which limited the range for long flights with little payload. For the second series of aircraft (S/N > 201), a third tank has been added, raising the total fuel capacity to 29,690 liters.

Fuel is divided as follows (for each wing):

- Tank "A": 5,740 liters, located in the middle of the wing.
- Tank "B": 4,285 liters, located between tank A and wing tip.
- Tank "C": 4,815 liters, located between tank A and wing root.

Tanks A and B are directly connected to fuel lines feeding engines and APU, while tanks C are isolated from the main fuel system and used as additional tanks if needed. Their content can be transferred to tanks A and B with a complex transfer system described in **fuel transfer** section.

Fuel consumed by the engines can be monitored from fuel flow indicators, and can be reset with the associated knobs. Left gauge also takes into account APU fuel consumption.



# Pumps & valves

As fuel tanks are located higher than engines and APU, gravity is sufficient in most cases to feed the engines. However, in certain conditions, for example when reservoirs are near empty, you will need to use electric pumps to get enough fuel pressure. Each tank A and B has two immersed pumps, that can be controlled with their dedicated switches on the center console.

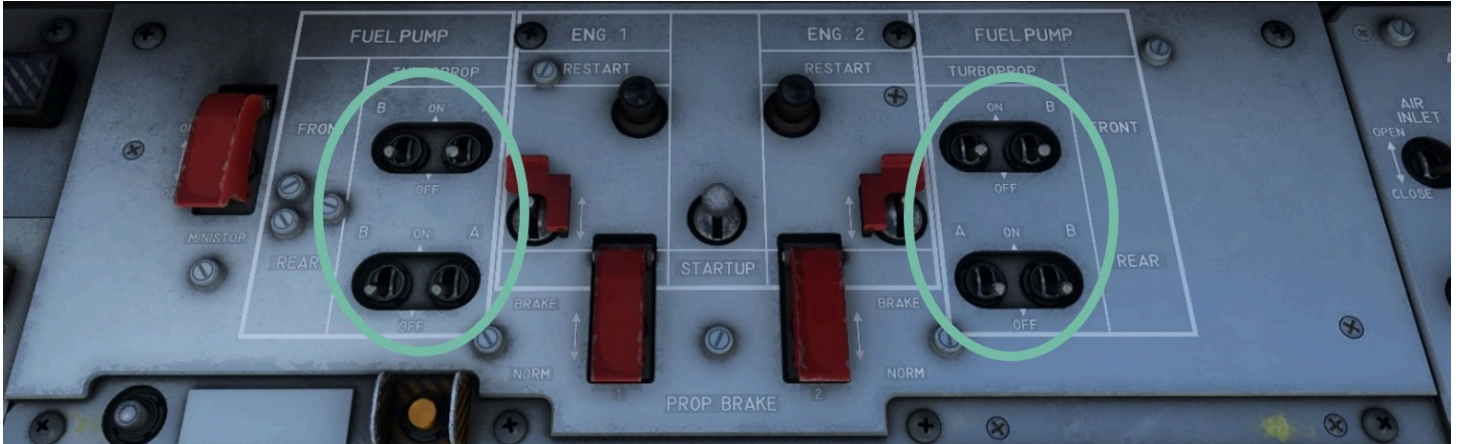

Those pumps should be functioning from the takeoff until landing to ensure a sufficient fuel pressure.

Several fuel valves allow to isolate each tank, left and right fuel lines, engines and APU. All of them are located on left and right sides of top console.

From left to right (pilot seat view):

- "VAPU", APU isolation valve.
- "VInter<sub>left</sub>", left fuel lines isolation valve.
- "VB<sub>left</sub>", left tank B isolation valve.
- "VA<sub>left</sub>", left tank A isolation valve.
- "VA<sub>right</sub>", right tank A isolation valve.
- "VB<sub>right</sub>", right tank B isolation valve.
- "VInter<sub>right</sub>", right fuel lines isolation valve.
- Fuel dump valve.

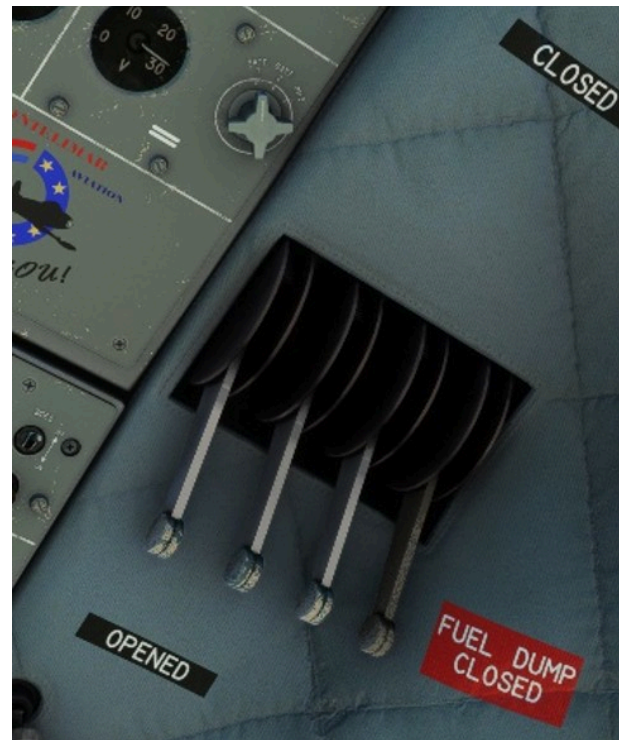

In case of engine fire, a cut-off valve directly located nearby the engine (or APU) can isolate the concerned engine or the APU from the rest of the fuel system.

Once fuel cut-off handle has been rotated, "REARM" buttons should be pressed to re-open the valve that has been shut.



Main engine valves do not have any manual handle but are automatically closed when condition levers are put in shut-off position.

Here is a detailed diagram of fuel system with tanks, lines, valves and pumps. Only left side is depicted as fuel system is symmetrical.

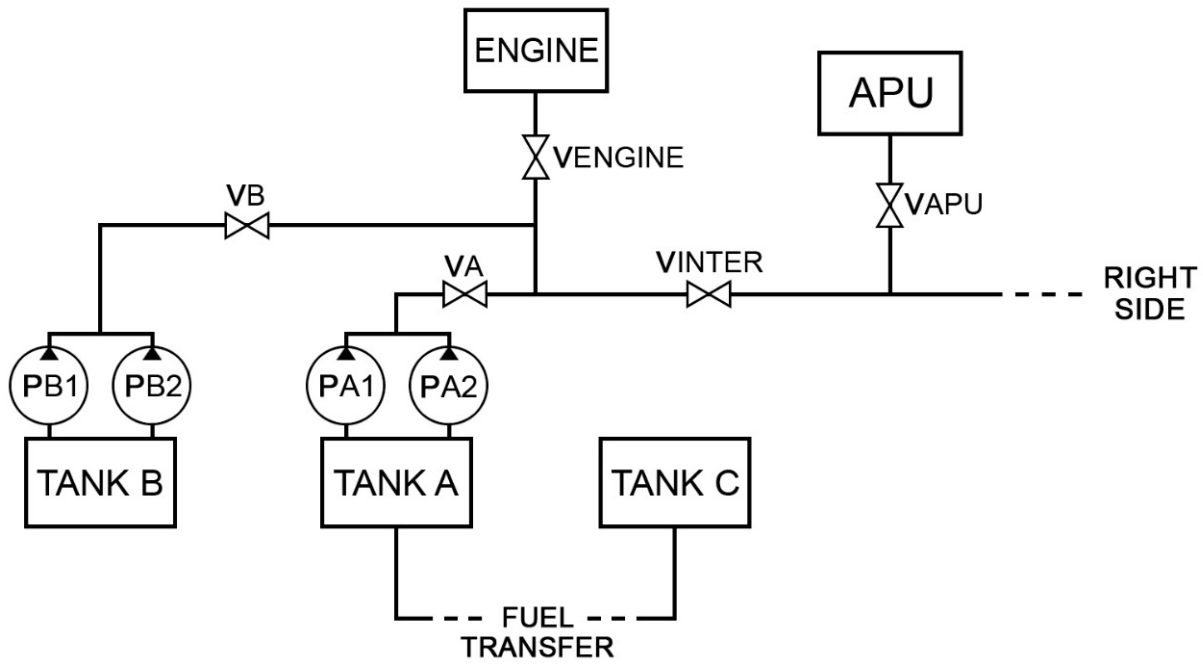

## Refill

Tanks can be filled instantly from the fuel menu or from the **tablet**.

For more realism, fuel transfer panel can be used to refill, after fuel truck is called from the ATC ground services and connected. Refueling switches can be put on "OPEN" position to start the refueling.

One light per tank indicates when it is full.

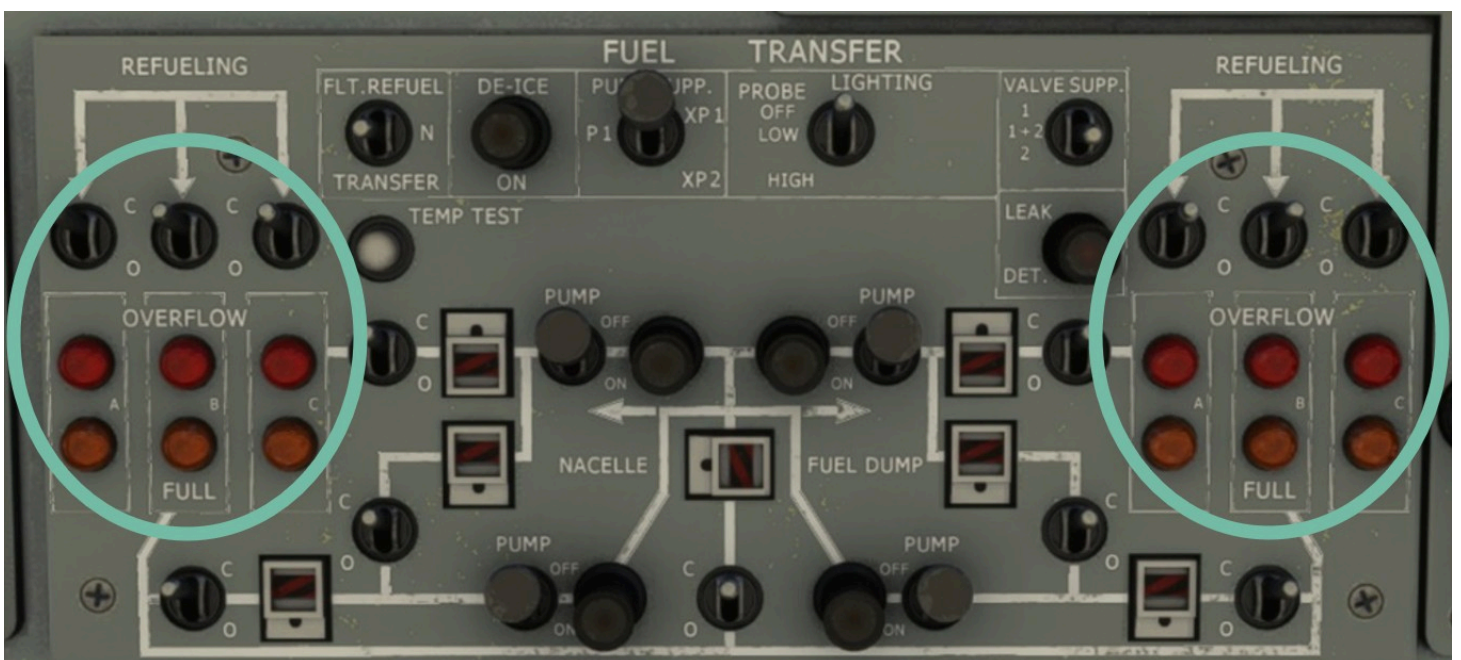

# Transfer & dump

As tanks C are not directly connected to the engines, a complex fuel network allows to transfer fuel between tanks A and C, on both sides of the aircraft. This same network is used to dump fuel in case of emergency.

This network is completely separated from engines feeding circuit described previously, and is composed of:

- Four electrical pumps.
- Seven fuel valves.

Each valve can be opened as needed to begin a fuel transfer with the help of fuel pumps. The panel directly shows fuel pathway along transfer lines.

Each of the pumps allows to push fuel out of the tank it is connected to.

In the following configuration, fuel will be pumped out of right tank C to be transferred to right tank A:

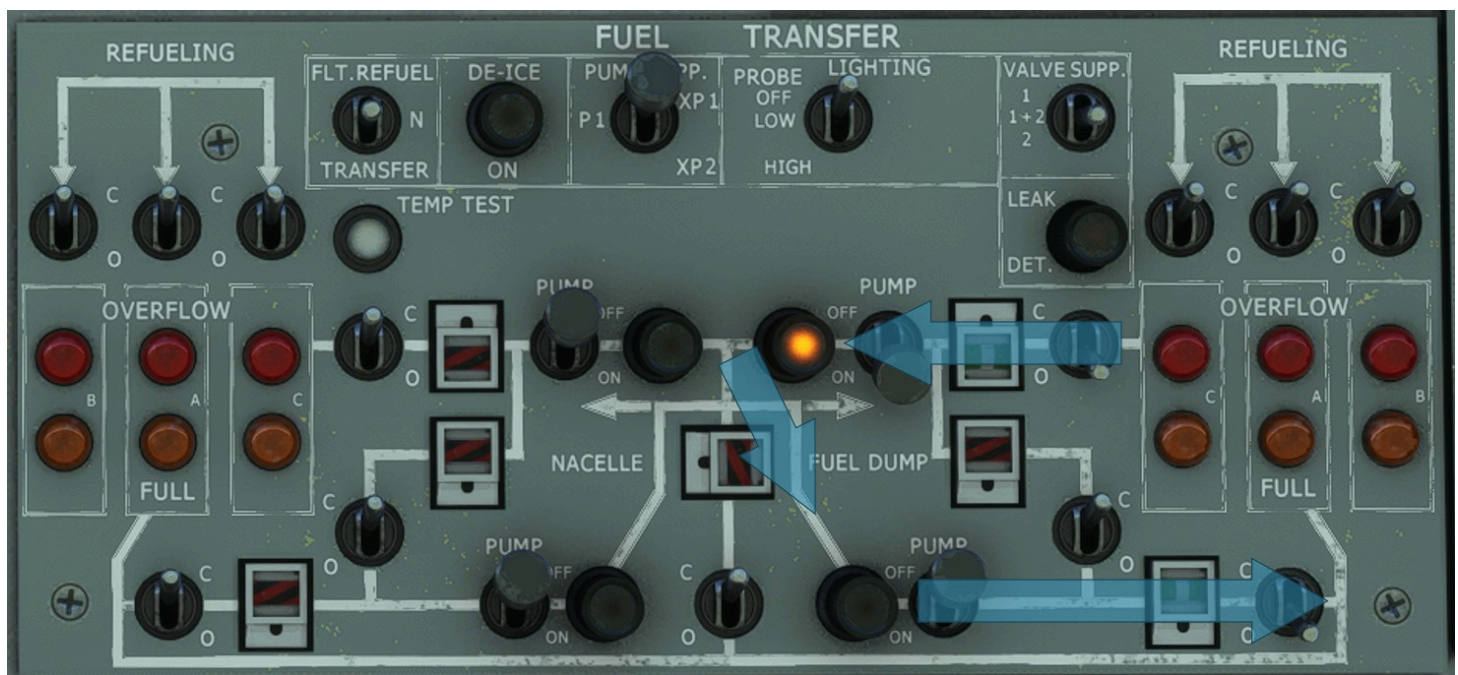

In the following configuration, fuel will be pumped out of right tank C to be transferred to left tank A:

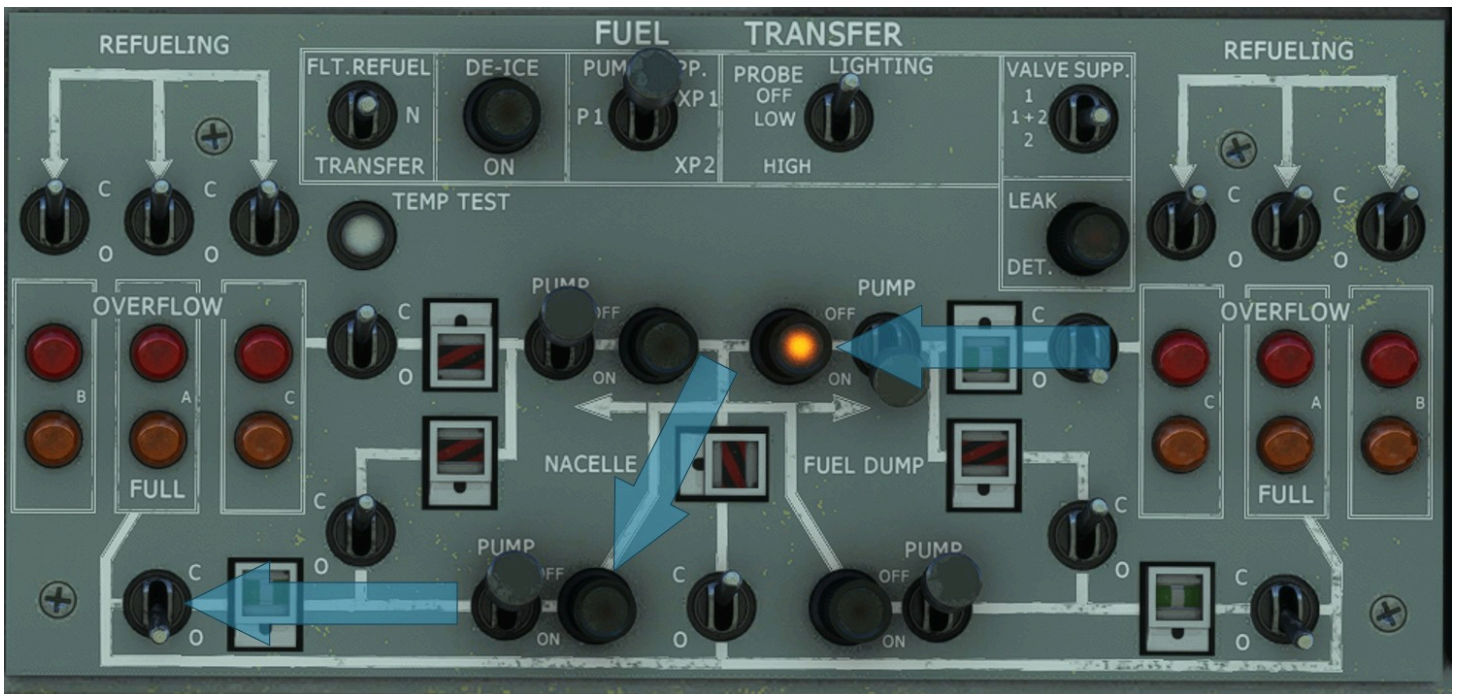

To dump fuel, valve associated to the tank to drain should be opened, and the associated pump turned on. Opening fuel dump valve handle will initiate fuel dumping.

Fuel circulates through pipes to the rear of the aircraft to be ejected from the nozzle serving this purpose.

In the following configuration, tanks C on both sides are drained:



**⚠ WARNING**

Because of limitations with current fuel system implementation, fuel can be transferred from tanks C to tanks A, but not the opposite.

# Hydraulics & controls

A lot of equipment of the aircraft relies on hydraulic power: landing gear, flaps, spoilers, ramp, propeller brake, nose wheel steering, wheel brakes.

It also assists flight controls with servo units for ailerons, elevator, rudder and spoilerons.

## Hydraulic generation

There are five separated circuits:

- **Green** main circuit.
- **Blue** main circuit.
- **Red** auxiliary circuit.
- **Yellow** auxiliary circuit.
- **Emergency brake** circuit.

In normal conditions only blue and green circuits are operated. Each main circuit is supplied by two self-regulated pumps, one on each engine.

Red circuit, yellow circuit and emergency brake circuit are only used in case of malfunction of one main circuit:

- Red circuit is supplied by an APU driven self-regulated pump.
- Yellow circuit is supplied by an electro-pump.
- Emergency brake circuit is supplied by a manual hand pump.

Overall hydraulic system can be monitored on the dedicated front panel section.



# Handling

## Ailerons & spoilers

Roll action is servo assisted with hydraulic power, to ease pilot action.

It is reinforced by spoilers to improve maneuverability at low speed. Spoileron is extended when aileron angle on the same side is above  $3^\circ$  and will reach its maximum angle ( $45^\circ$ ) when aileron angle is above  $10^\circ$ .



	<b>Delta Angle</b>
Ailerons	+25 ° / - 15 °
Spoilerons	0° / 45 °

In addition, an electronic trim is available to balance engine gyroscopic effects. It is controlled by a switch located on the right top of both yokes and monitored on the front panel "roll trim" gauge.



## **Elevator & rudder**

Yaw and pitch axis are also servo assisted with hydraulic power. An artificial feedback system simulates a muscular effort to the pilots. It can be deactivated using the dedicated switches on upper console left panel.



As for ailerons, rudder has its own electrical trim. It is controlled by a switch located on the top left of both yokes.



Pitch trim is controlled by a wheel which also includes an angle indicator. This trim has a direct link with the yoke that will move forward and backward accordingly.

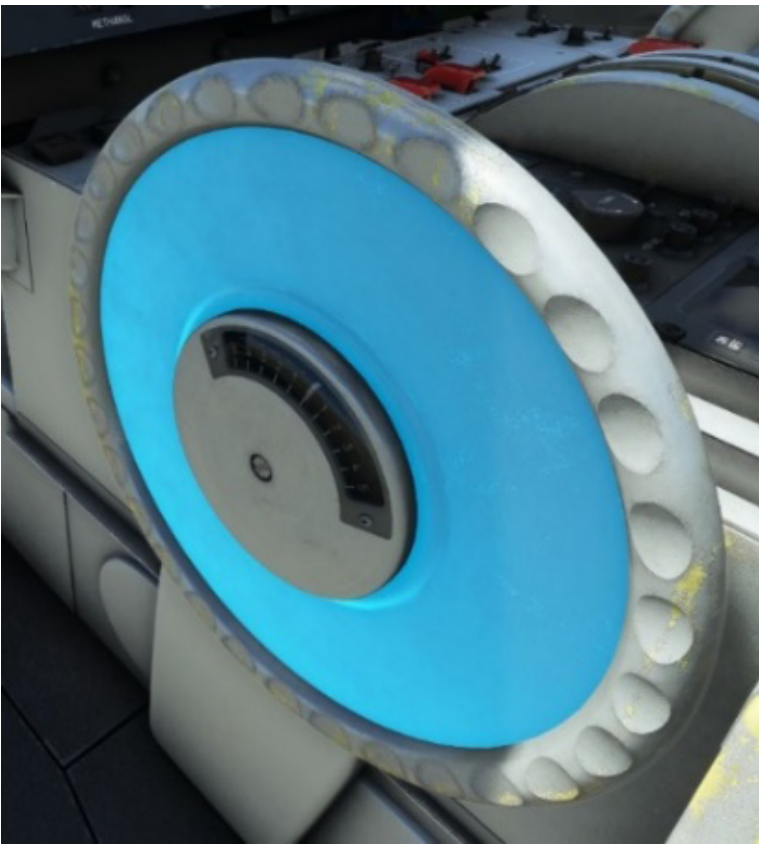

## Flaps

Flaps system is composed of a symmetrical set of two side flaps and two central ones. They are hydraulically powered with two actioners per set (one normal, one rescue). Rescue actioner is supplied by red hydraulic circuit whereas the normal circuit is supplied by green circuit. An anti-twist safety system prevents any twist of the flaps system.

Flaps handle is located in front of center console:

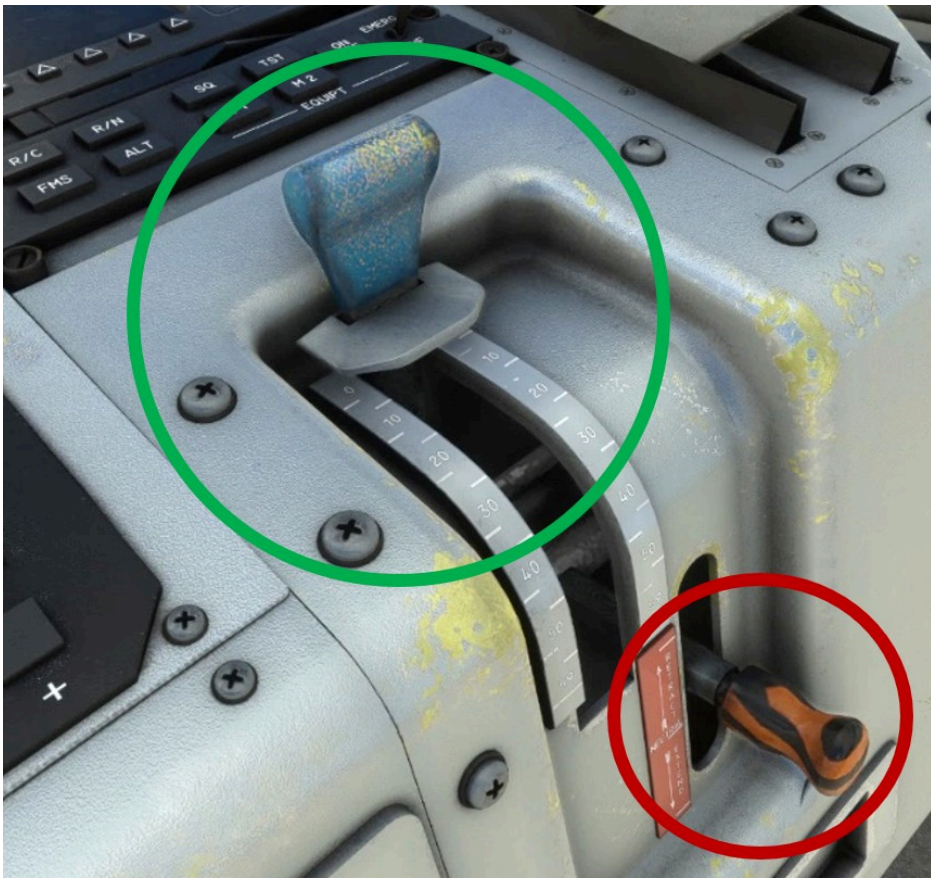

In case of hydraulic failure on the main (green) circuit, an emergency lever is available to operate flaps using red hydraulic circuit.

## Spoilers

Spoilers are also hydraulic driven. Their dedicated switch is normally located on the pilot power lever. It has not been modeled on our Transall as targeting it with the click is too difficult.

### **(i) NOTE**

Spoiler action needs to be bond to a controller key.

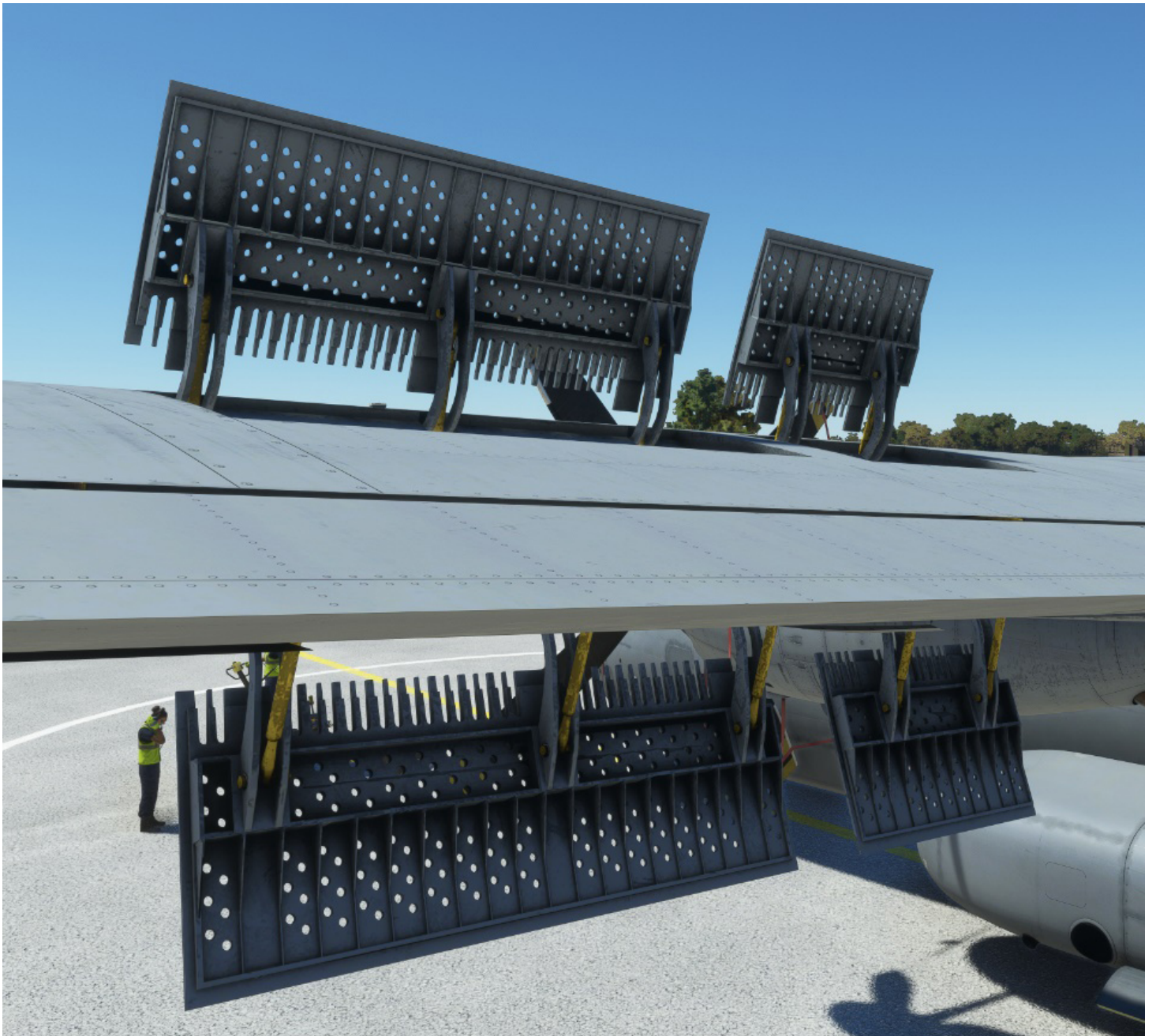

In case of hydraulic failure with spoilers extended, an emergency lever allows to retract them.



## Landing gear

### Description

The Transall is known for its capacity of landing in almost any kind of surface. That is made possible thanks to its landing gear system made of a strong fully retractable tricycle landing gear.

Main landing gear design allows an important amount of energy absorption. It is mainly due to its complex hydraulic system that permits:

- High amplitude and chocks absorption.
- Fuselage lowering and elevation.

Front wheel has steering capacities of  $\pm 55^\circ$ .

## Controls

Landing gear lever has four positions:

- UP (retracted): normal sequence of gear retracting.
- DOWN: normal sequence of gear extension.
- EMERG (emergency): unlocks landing gear hatches.
- MECHANICAL STOP: emergency sequence of gear extension using red hydraulic circuit.



Green hydraulic circuit must be available for normal sequences to work correctly. The two other positions are used in case of emergency only.

A set of five green lights indicate that landing gear is down and locked (front landing gear and each axle of main landing gear). Red light indicates that landing gear and hatches are maneuvering and not locked.

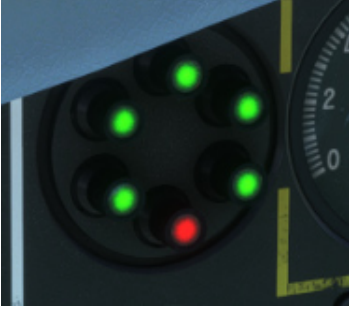

A red light will glow if landing gear is not down and locked while airspeed is below 115 knots and throttle position is low.



On upper console, a set of red lights indicate more precisely which part of the landing gear or which hatch is currently maneuvering.



## Steering

Nose wheel is not mechanically linked to the rudder and is operated with a tiller positioned on left side of the pilot.

**i NOTE**

For simulation purpose, any action on rudder will be applied to the nose wheel as well.

## Brakes

Wheel brakes are hydraulically actuated by green hydraulic circuit, and emergency circuit (hand pump) when main hydraulic power is not available.

Differential brakes are actuated from pilot and copilot rudder pedals.

Two handles located on center console are used as emergency brake, one of them having a locking system for parking brake.



An anti-skid system, called "mini-stop" is enabled from center console. It is automatic and will minimize braking distances depending on wheels rotation speed and ground adherence.



# Cargo loading & dropping

## Exits

All exits are operational on our Transall. In addition to the three side doors, cockpit windows can be operated.

Rear exit is composed of two parts, a lower ramp that can descend to the ground and a higher door that is raised to provide a sufficient space to load and unload the aircraft. Both parts can be operated independently from the electronic flight bag (EFB).

Here is a recap:

Exit	Command	EFB shortcut	Conditions
Cockpit windows	Window handle	N/A	Aircraft on ground

Exit	Command	EFB shortcut	Conditions
Side door (front)	N/A	Payload tab	Aircraft on ground
Side doors (rear)	N/A	Payload tab	N/A
Ramp	Top console (dropping panel)	Payload tab	Hydraulic power must be available Ramp should not be opened above 162 kts

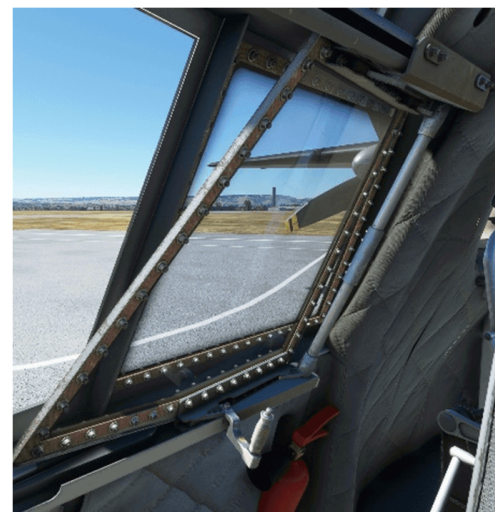

## Lowering

In order to facilitate cargo loading and unloading, the C160 has the ability to “kneel”, by lowering the rear-end of its fuselage.

This feature is hydraulically driven. Either green or red hydraulic pressure must be available for this operation.

In the simulator, the sequence is automated and stops at a defined position. It can be triggered either from the EFB, or using the front panel raising switch. An indicator light indicates when fuselage is lowering.

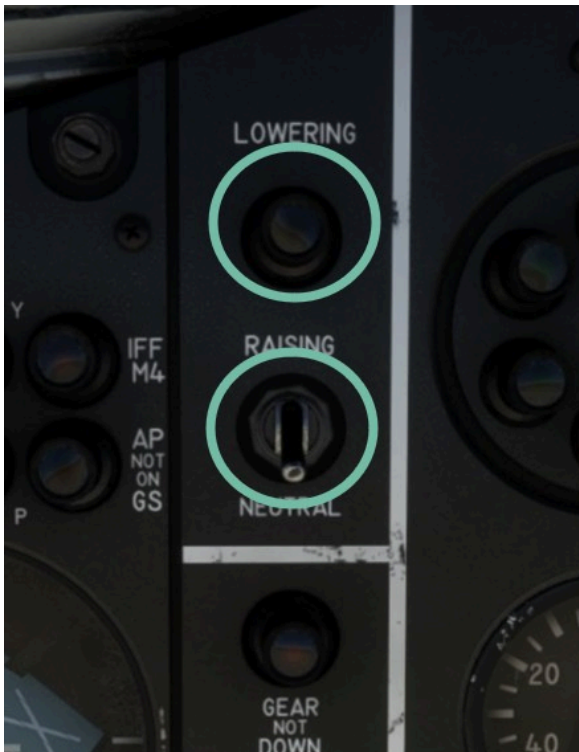

Front panel switch can only raise the fuselage. In the real aircraft, lowering is not automated and must be carried out by an operator on a dedicated panel in the cargo bay.



## Cargo

Our Transall can carry various cargo objects (vehicles, boxes, pallets, troops, etc), selectable from electronic flight bag (payload page).

All objects cannot be selected at once as some of them are at the same location in the cargo bay.

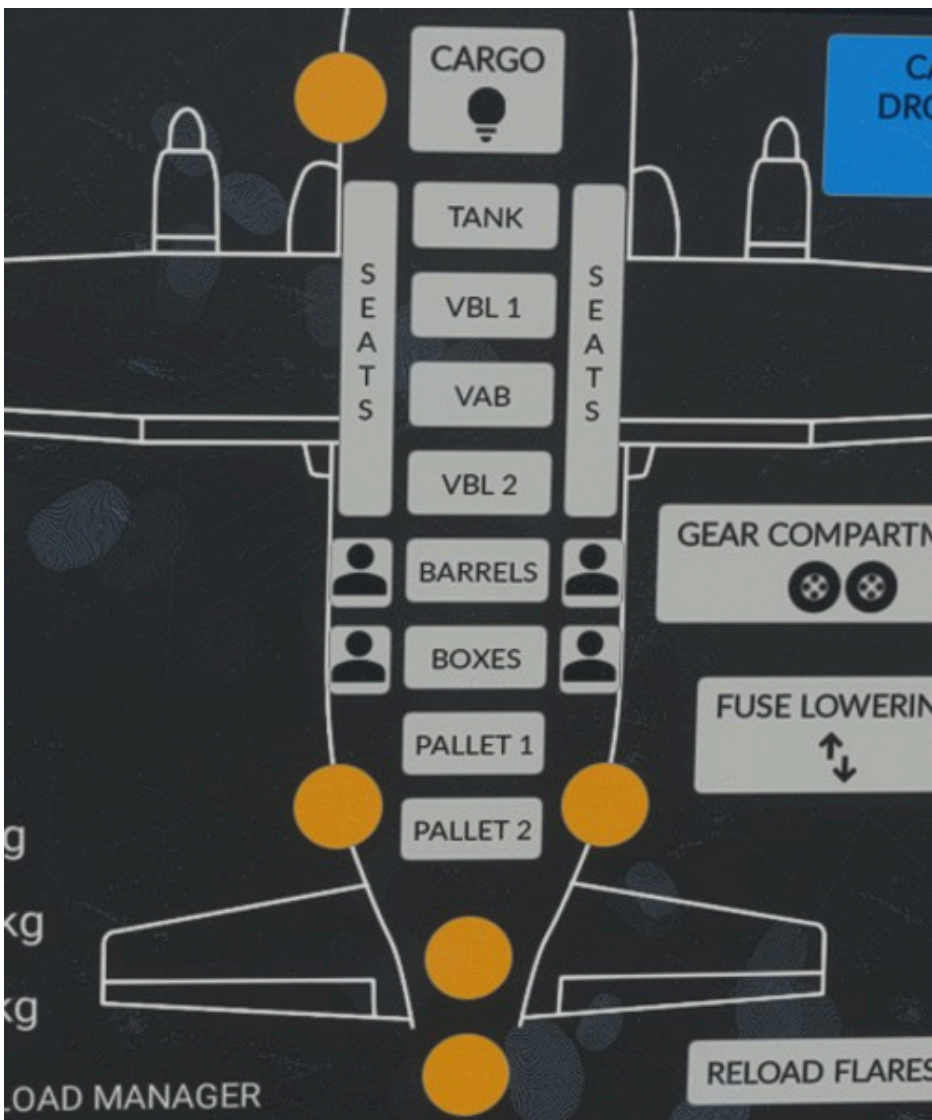

When any payload is added, aircraft weight is updated accordingly. Be careful as it is very easy to exceed maximum takeoff weight, especially with vehicles (VAB and VBL).

If you prefer to manage weights manually from the simulator payload menu, you can disable syncing from the EFB, and cargo objects selected will not overwrite current aircraft weight.

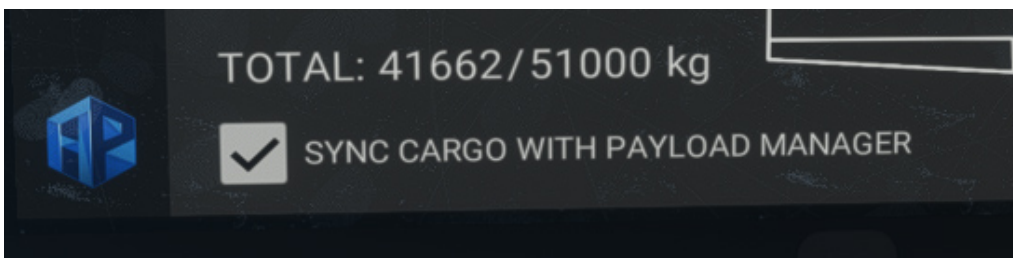

## Dropping

VBL vehicles and troops can be dropped from the cargo, after being added from the EFB, by switching to cargo dropping mode.

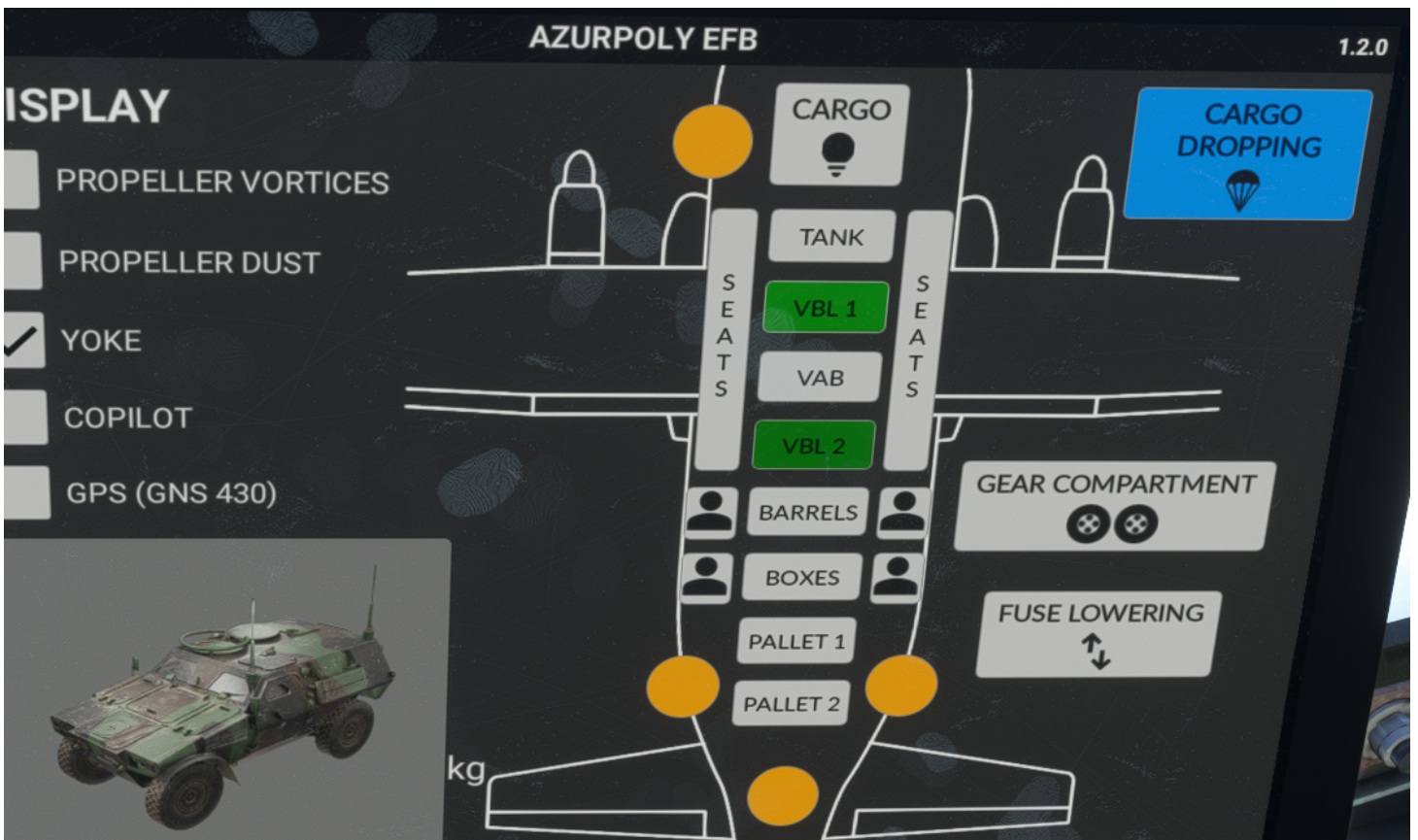

Four different scenarios can be triggered:

- Drop front VBL vehicle.
- Drop rear VBL vehicle.
- Drop seated troopers (one to four soldiers, with cargo exit animation).
- Drop all troopers (ten soldiers without cargo exit animation).

 **MSFS 2024 NATIVE VERSION ONLY**

Up to 11 seated troopers can be displayed, and dropped one by one or all together.

Buttons are grayed out if all conditions for dropping are not met (closed cargo ramp for example, or rear VBL blocking front VBL).

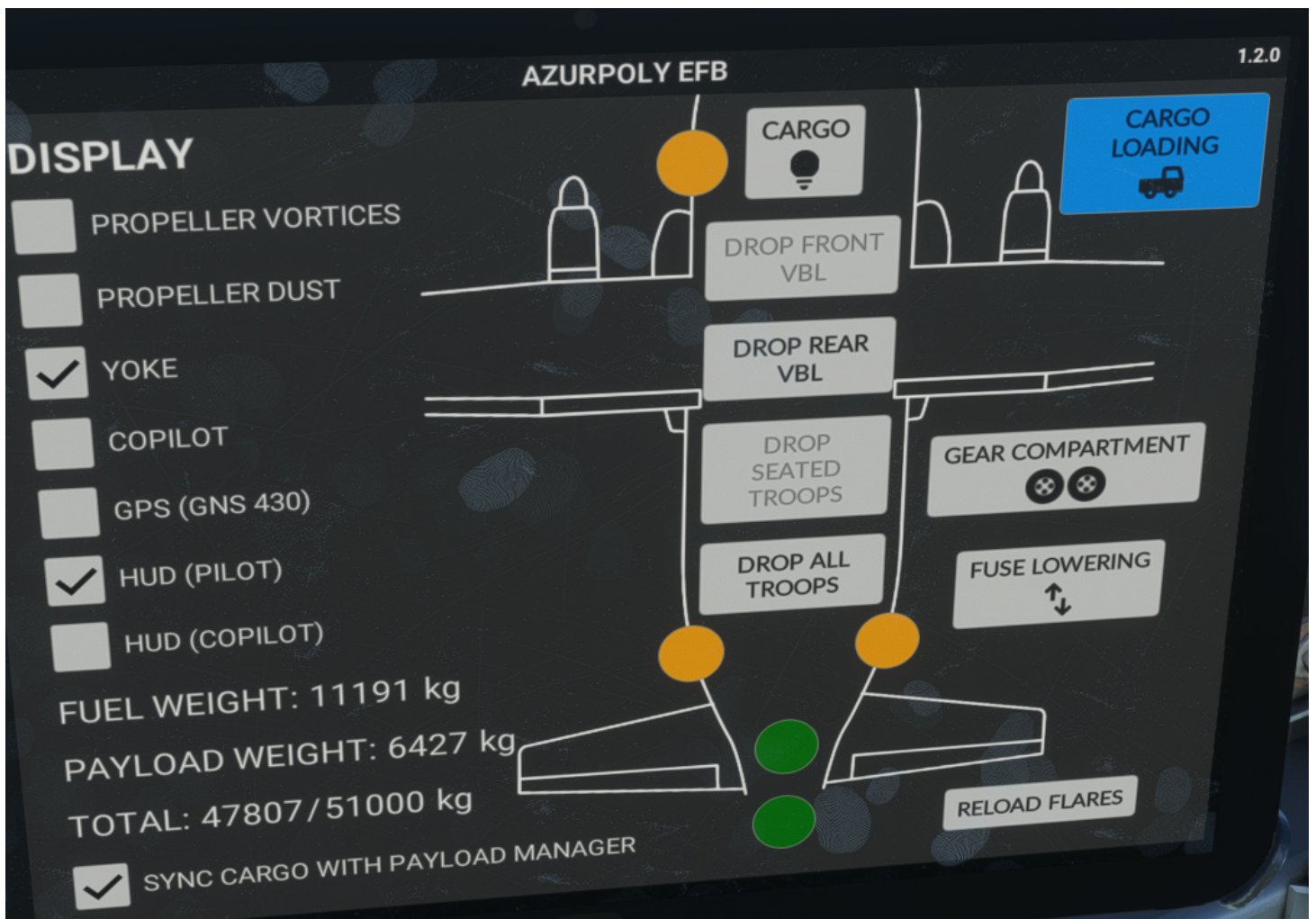

**💡 MSFS 2024 NATIVE VERSION ONLY**

Side doors must be opened in order to drop paratroopers.

Cargo panel located on upper console will display:

- One green light "DROP POSITION" when dropping conditions are met.
- One green light "DROP" when dropping is ongoing.



Dropping scenario will be launched few seconds after clicking on the button, in order to have time to change camera.



**i NOTE**

Cargo dropping is an experimental feature which can take up a lot of resources depending on your computer specifications. You could see some flickering on cargo animations which is totally normal.

# Other systems

## Cabin environment and pressurization

Both cockpit and cargo bay are pressurized, thanks to one compressor linked to each engine. Compressed air has a temperature of 120 °C when collected, and is cooled with refrigerator groups.

Conditioned air can be obtained from the APU as well when none of the engines are functioning.

## Air conditioning

Inside temperature can be set up to +18°C for outside temperatures down to -56°C. It can also be set to outside temperature minus 5°C for an outside temperature up to +56°C.

Bleed air valves can be opened and closed from a dedicated panel on top console. Once engines bleed air valves are used for conditioned air supply, APU valve is automatically closed. At least one bleed valve needs to be open to ensure a functional air conditioning.

Current cabin temperature is indicated by a needle, and temperature knob is used to select desired temperature (from COLD to WARM positions). Few minutes are needed to change temperature in the whole cabin, depending on outside air temperature.



Left part of the panel is dedicated to compressors state with several lights:

- Compressor oil overheat.
- Compressor low oil pressure.
- Compressor speed change. A gearbox is linked to compressor output to manage two speeds depending on engine rotation speed. Light is on when compressor is running in "low speed" mode.

## Pressurization

Pressurization allows to get a maximum equivalent altitude of 10,000 feet for an actual altitude of 25,000 ft.

Two knobs allow to select target altitude and rate of change. Target altitude is the equivalent cabin altitude you want to reach while in cruise.

Effective cabin altitude, rate of change and differential pressure are indicated on the right part of the panel, along with depressurization valve that is secured by a hood.



Alarms will be triggered if differential important or cabin altitude are too important. You may need to increase cabin target altitude in this situation.

Pressurization will be lost in the following scenarios:

- Bleed air valves are closed.
- A door is opened.
- Depressurization valve is opened.

#### **i** NOTE

Target rate of change is different from actual rate of change which is automatically managed by the simulator most of the time.

## **Self-protection (flares)**

The Transall is not intended to perform any attack, but has a self-protection based on a decoy flares launcher.

Those flares can be launched manually on the simulator, whereas an autonomous system detects potential threats in the real aircraft.

Once the system is turned on, number of remaining flares is indicated on a small screen. Four salvos of 16 flares can be triggered, and flares can be reloaded from the EFB if needed.



#	Description	#	Description
1	Power switch	5	Launch ready light
2	Threat detection mode switch (inoperative)	6	Launch ongoing light
3	Flares launch button	7	Remaining flares counter
4	Flares system operative light	8	Empty flares light

Once fire button is pressed, flares will be launched five seconds later.

Launch button can be bound to *EMERGENCY WAR POWER* in controls options.

Display on MSFS 2020:



Display on MSFS 2024:



# Avionics

Our Transall is based on the C160R version, which has more complex avionics compared to previous versions, including screens instead of gauges.

We decided to develop full bespoke systems without re-using existing avionics from the simulator, hence several of them are not fully implemented yet and will be enhanced in future updates.

## EFIS

Flight instrument system consists of two main screens for both pilot and copilot:

- Electronic Attitude Director Indicator (EADI).
- Electronic Horizontal Situation Indicator (EHSI).

## EADI

Primary screen displays general information about aircraft attitude and speed.



#	Description	#	Description
1	Attitude	7	Autopilot state
2	Decision height reached indicator	8	Autopilot lateral mode
3	Glideslope deviation indicator	9	Autopilot vertical mode
4	Airspeed	10	Spoilers extended indicator
5	Radio altitude	11	ILS marker flag (outer/middle)
6	Decision height selection		

Radio altitude is displayed if it is below 2,500 ft, with an increment of 5 ft below 50 ft and 10 ft above.

If decision height is set with the associated DSP knob, indicator will appear once it is reached and will stay unless aircraft is landed or decision height is changed again.

“AP/L” inscription indicates that autopilot is managed by the pilot (only option available for now), and becomes green once autopilot master is on. “LOW” inscription is displayed below 160 knots to indicate a

different operating mode where gains on commands amplifiers are reduced (on the three axis).

On top of the screen, current autopilot mode is displayed.

Possible lateral modes are:

- "HDG" for heading selection mode.
- "ROLL" for bank angle hold mode.
- "LOC1"/"LOC2" for localizer capture mode (ILS approach) on NAV1/NAV2.

Possible vertical modes are:

- "ALT" for altitude hold mode.
- "GS1"/"GS2" for ILS glideslope capture mode on NAV1/NAV2.
- "FMS1" for FMS or GPS trajectory mode.
- "TCN" for TACAN radial following mode.
- "VOR1"/"VOR2" for VOR radial following mode on NAV1/NAV2.

Once a mode is captured (trajectory locked), its text switches from white to green color.

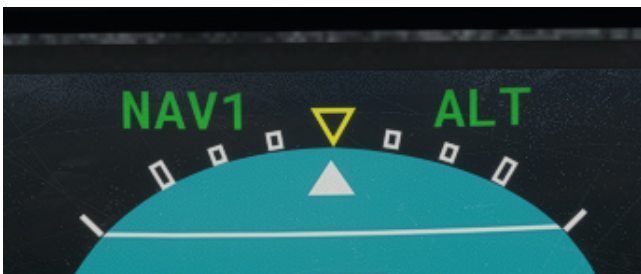

## EHSI

Secondary screen is based around a central rose indicating aircraft heading, and information related to radionavigation and flight plan navigation.

EHSI has three different possible displays: HSI, ARC and MAP.

### HSI mode



#	Description	#	Description
1	Distance to station	5	Double arrow indication
2	Navigation sources and active one	6	Dynamic data display zone
3	Heading reference bug	7	Course selected for active source
4	Single arrow indication	8	Next flight plan waypoint ident

Single arrow can display VOR1 course (with deviation), ADF station direction or FMS1/GPS next waypoint direction.

Double arrow can display whether VOR2 course or TACAN course, with deviation.

Current source selected for CRS selection and distance display is indicated by a small white border.

By default, arrows are hidden and "NONE" is displayed as active sources.



Heading reference bug represents target heading and will be used by the autopilot when it is running in heading selection mode.

**ARC mode**



#	Description	#	Description
1	Distance to station	6	Map range
2	Navigation sources and active one	7	VOR/ADF/TAC/waypoint position
3	Heading reference/target	8	Course selected for active source

#	Description	#	Description
4	Single and double arrows indication	9	Dynamic data display zone
5	TO/FROM flag		

In ARC mode, main difference is that background corresponds to a map with range, showing the position of VOR/ADF/TACAN beacon or next FMS/GPS waypoint, depending on active navigation source.

When heading reference/target is outside of displayed arc angle, its value is written on the sides.

### MAP mode



#	Description	#	Description
1	Distance to station	5	Map range
2	Heading reference/target	6	Dynamic data display zone
3	Flight plan active segment	7	Course selected for active source
4	Flight plan route and waypoints		

In MAP mode, only flight plan is displayed with departure airport, all its waypoints and arrival airport.

Map range can be changed to display a bigger part of the flight plan.

It is important to ensure IRS is switched on and aligned in order to see flight plan correctly.

### Dynamic data display zone

Top right zone data to display can be changed with DSP data display knob as described in next subsection.

- Option 1**   **Option 2**   **Option 3**   **Option 4**

Wind speed and direction (relative to aircraft).



### Display selector panel

EFIS commands are gathered on Display Selector Panel (DSP).



#	Description	#	Description
1	EHSI data display knob	7	Active course selection knob (inoperative)

#	Description	#	Description
2	Change heading target reference ( <i>rotation</i> ) Set heading target to current heading ( <i>click</i> )	8	Set navigation OBS ( <i>rotation</i> ) Set direct-to course ( <i>click</i> )
3	Set countdown duration ( <i>rotation</i> ) Start/stop chronometer or countdown ( <i>short click</i> ) Reset chronometer ( <i>long click</i> )	9	Set single needle source (NONE, VOR1, ADF or FMS1)
4	EHSI rose display mode knob	10	Set double needle source (NONE, VOR2 or TACAN)
5	EHSI range selection knob	11	Toggle active navigation source
6	Decision height setting knob		

Another more accessible button allows to start and stop chronometer on both pilot and copilot sides:



## IRS

Inertial Reference System (IRS) relies on several internal and external sensors to elaborate several information needed to fly the aircraft, like attitude, angular velocities, accelerations, ground speed, position.

Two of them are disposed in our aircraft and are redundant. They should be running at any time during the flight.

IRS is functioning when the knob is on "NAV" position, after which an initialization sequence of approximately 30 seconds will take place. A parallel GPS system allows to determine initial position, and IRS is able to know aircraft position at any time from that point.

Four orange lights can be displayed:

- "ALIGN MODE": IRS in alignment mode.
- "BAT OPER": generators not providing any current, electricity supplied by the batteries.
- "BAT WARN": batteries not able to ensure correct function of the IRS.
- "IRS WARN": IRS malfunction.



**NOTE**

"ATT" is a test position which is not simulated.

## FMS

Flight management system has been added in modern C-160 versions (NG) to manage everything related to radio and flight navigation. It is linked to all other aircraft systems (EFIS, autopilot, etc).

Our Transall does not have 100% of its original functionalities but everything needed to navigate with a flight plan.

Both FMS units (pilot and copilot) allow to achieve the same actions.

**WARNING**

Do not forget to switch IRS on in order to be able to use all functionalities.

## Overview

Generic structure of an FMS page is the following:

- Top status line.
- One title line.

- Eight lines with dynamic data depending on the active page.
- One line for current keyboard entry.
- A bottom line with five potential actions.



#	Description	#	Description
1	Power button (hold to turn off)	12	Help button
2	Screen brightness buttons	13	Radiocommunication page
3	Line pointer change button	14	Radionavigation page
4	Screen	15	Leave FMS mode
5	Hold button	16	Altitude page
6	Letter selection button	17	Mute selected equipment
7	Keyboard	18	Test selected equipment
8	Variable label keys	19	Equipment mode 1
9	Clear button	20	Equipment mode 2
10	Enter button	21	Turn selected equipment on/off
11	Expand button	22	UHF emergency frequency

Ten keys allow to write any digit between 0 and 9 from the keyboard.

In order to write any letter, you first need to click on the corresponding key where this letter appears, and then to choose one of the three letter selection buttons (above keyboard) depending on the position of the letter you want to write on its key.

In the following example, letter "H" is entered:



## INIT1 page

After FMS is started, INIT1 is the first page displayed.

Once IRS is aligned, initialization coordinates are displayed. They cannot be entered manually.

Flight number can be entered on the first line (free format).

Second line displays departure and arrival airports (OACI code), that can be changed to begin a new a flight plan. To do this, put the cursor on this line, enter both OACI codes with the keyboard and click on ENT.

Fourth line shows departure airport and allows to access departure page.



## INIT2 page

By clicking again on first label key (INI), INIT2 page is displayed.

You can enter on first three lines (tons unit):

- Aircraft empty weight.
- Fuel weight.
- Load weight.

Gross weight will be calculated automatically by summing those values.

You can also set local QNH, ground air temperature and flaps setting used for takeoff.



## DEPARTURE page

To enter departure page, you need to select AIRPORT line on INIT1 page, and click on EXP.

Departure page shows airport ICAO, coordinates, elevation and longest runway length.



**⚠ WARNING**

You have to select the departure **before** choosing any runway.

After selecting SID line and clicking on EXP, list of available standard instrument departures (SID) is displayed. You can select on with ENT button.



Only once departure procedure is selected, you can access runway page (with EXP button) and select departure runway from the list with ENT button.



## FLP1 page

FLP1 page contains flight plan waypoints list. Only next waypoints are displayed, and they are removed once reached.

It is accessed from INIT pages using FLP action button.

You can see for each waypoint:

- Estimated time of arrival (ETA), depending on current ground speed.
- Heading to the next waypoint.
- Distance to next waypoint.

In order to reset the flight plan completely, do a long click on CLR button (with the cursor on any line).



## FACILITY page

After selecting any waypoint on FLP1 page, you can access facility page with EXP button.

This page shows waypoint coordinates, plus magnetic variation and frequency if the waypoint is a VOR.

You can exit the page with RTN action button.



## ARRIVAL page

To access arrival page, you need to click on EXP button after having selected arrival airport on FLP1 page (which is the last waypoint of the list).



You can then select standard instrument arrival (STAR) and runway as you would select a SID and a runway on departure page.

**⚠ WARNING**

You have to select the arrival **before** choosing any runway.

**📘 NOTE**

As weird as it may seem, Transall FMS does not allow to set an approach (ILS, etc), you need to manage it manually.

## FLP CHANGE page

This page is the only place to edit the flight plan.

After selecting a waypoint on FLP1 page, you need to click on CHG action button.

From there are three possible actions:

- Entering a new waypoint to be inserted before selected waypoint.
- Change selected waypoint to another waypoint.
- Delete selected waypoint.

After selecting one of these actions with ENT button, you will need to click ENT a second time to confirm.

Once action is submitted, FLP1 page is displayed again.

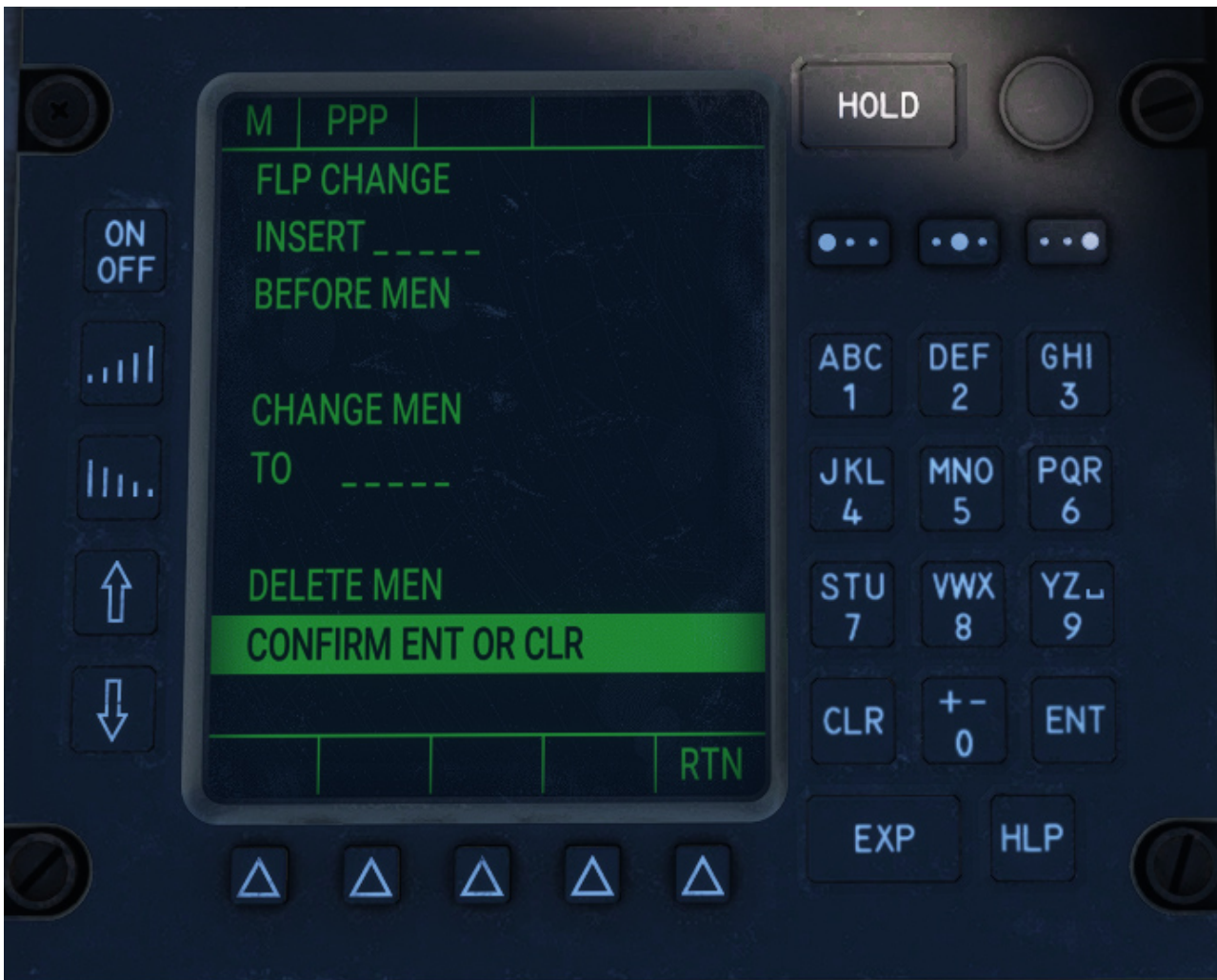

## FLP2 page

When clicking on FLP action button, FLP2 page is displayed with information related to next goal:

- Ident of the waypoint.
- Straight heading to the waypoint.

- Current distance between aircraft and waypoint.
- Heading to follow desired track (DTK), which is the line between previous and next waypoint.
- Cross track distance (XTKR) representing deviation from desired track.
- Current wind (direction and velocity).
- Current GPS track.
- Current ground speed.
- Current fuel flow (kilograms per nm).
- Total remaining fuel (tons).



## DIRECT TO page

This page allows to go directly to a specific waypoint of the flight plan by skipping all the previous waypoints.

You can access the page after selecting a waypoint on FLP1 page and clicking on DTO action button.

Clicking on GO action button will apply the modifications to the flight plan.



## COM page

This page shows active and standby radiocommunication frequencies on channels 1 and 2.

To change a frequency:

1. Go to desired line with left pointer buttons.
2. Enter frequency with the keyboard (for example 11825). Frequency pattern is displayed in background of the current entry.
3. Click on ENT to change active frequency, or PRE to change standby frequency.
4. Select XFR action to switch standby and active frequencies.



## NAV page

This page shows active and standby radionavigation frequencies for NAV, ADF and TACAN.

To change a frequency:

1. Go to desired line with left pointer buttons.
2. Enter frequency (or TACAN channel) with the keyboard (for example 11050). Frequency pattern is displayed in background of the current entry.
3. Click on ENT to change active frequency, or PRE to change standby frequency.
4. Select XFR action to switch standby and active frequencies.



## ALTITUDE page

This page allows to change target altitude for the autopilot, and barometric reference.

It also shows current Static Air Temperature (SAT) and Total Air Temperature (TAT).



## Autopilot

Autopilot ensures aircraft stability around three axis (roll, pitch, yaw) without any manual actions needed on the controls.

As it is based on default autopilot implementation, you can bind any autopilot function to your controller (from controls options).

The following functions are covered by the system:

- Current heading hold (HDG HOLD).
- Selected heading interception and hold (HDG SEL).
- Selected pitch hold (PITCH).
- Selected bank angle hold (TURN).
- Selected altitude interception and hold (ALT).
- Radionavigation route interception and hold (RADIO), connected to NAV1, NAV2, TACAN and GPS.

Once master switch is on, heading and pitch hold are activated by default.

Bottom row of buttons has integrated lights that are on when the given function is activated.



#	Description	#	Description
1	Master autopilot switch	5	Altitude selection mode button and light
2	Flight director instruction bars (three axis)	6	Heading selection mode button and light
3	Pitch hold value selection switch	7	Radio button and light
4	Bank hold value selection knob	8	Heading hold button and light

Yoke has a specific switch in order to display flight director command bars over EADI:



## Horizontal

Default horizontal mode is heading hold (HDG HOLD), which levels wings to keep aircraft heading at the moment the function is enabled.

With bank angle hold (TURN), autopilot will keep a precise bank angle that can be set between -32 and +32 degrees by rotating the knob.

In heading selection mode (HDG SEL), autopilot will target the direction set by heading bug on the EHSI.



## Vertical

Default vertical mode is pitch hold (PITCH) that allows to target a precise pitch angle, set from the switch. Switch is unstable and will increment or decrement target angle each time it is moved (UP and DN positions). When autopilot is enabled, current pitch is maintained.

A target altitude can be set from the FMS or the EFB. Clicking on ALT button does not allow to go to a different altitude, but only to engage target altitude interception.

You need to use PITCH switch to select desired climb/descent rate. When the aircraft will arrive to target altitude, autopilot will automatically intercept and maintain it, with ALT light being on.

Here are the steps to follow to climb to a given altitude:

1. Enter target altitude (inside FMS or on the EFB tablet).



2. Engage autopilot that will automatically maintain current pitch.



3. Use flight director display to see pitch target value, that can be changed with PITCH switch.



4. ALT button will light up when target altitude is being intercepted.



5. ALT mode is now engaged and altitude is maintained.



## Radio

Radio mode allows to intercept radials automatically based on NAV and TACAN frequencies, or to follow a GPS/FMS path.

Before enabling RADIO mode, please ensure that GPS/VLOC mode is set correctly with the following switch:

- To "VLOC" if you want to follow a VOR/LOC/TACAN radial.
- To "GPS" if you want to follow a GPS/FMS route.



Then, ensure active source corresponds to the signal you want to follow (active source has a white border). In the following case, VOR2 radial will be tracked:



After clicking on RADIO button, active lateral and vertical modes will be displayed on top of the EADI as described [here](#).

Radio mode is not magical and you will need to fly close to the track you wish to intercept before enabling the mode.

If current frequency is tuned to a VOR/TACAN station, autopilot will intercept currently selected radial and maintain it as long as a valid signal is received.

If an ILS frequency is tuned, autopilot will intercept both localizer (horizontal guidance) and glideslope (vertical guidance).

 **WARNING**

When a GPS unit is displayed (GNS 430 or GTN 650), Working Title systems are used to manage the autopilot. For this reason, GPS track from the GNS/GTN will be followed in radio mode instead of FMS flight plan (which can be different as GPS and FMS flight plans are not synchronized). That is why we advise not using GPS and FMS navigation at the same time.

## GPS

French Transall did not have any GPS display installed. However, we decided to add a GPS unit that you can display optionally from the EFB tablet.

It is based on the Working Title implementation which allows you to manage flight plans and navigate more easily.

It is connected to COM1/NAV1 frequencies.



In MSFS 2024, you can also display a GTN 650 unit (PMS50 or TDS Sim Software).



As described in **autopilot** section, GPS route can be automatically followed by the autopilot in radio mode.

**⚠ WARNING**

As GPS is using its own flight plan implementation, we strongly discourage to use it to manage flight plan at the same time as the FMS, as it could lead to wrong behaviours.

## HUD

French Air Force C-160NG models were lately retrofitted with head up display (HUD).

It can be displayed on both pilot and copilot seats, from the EFB tablet:

- Left knob allows to turn the unit on and set the luminosity.
- Right button makes the unit entering a test mode where two circles are displayed on the center, allowing to adjust seating position correctly.

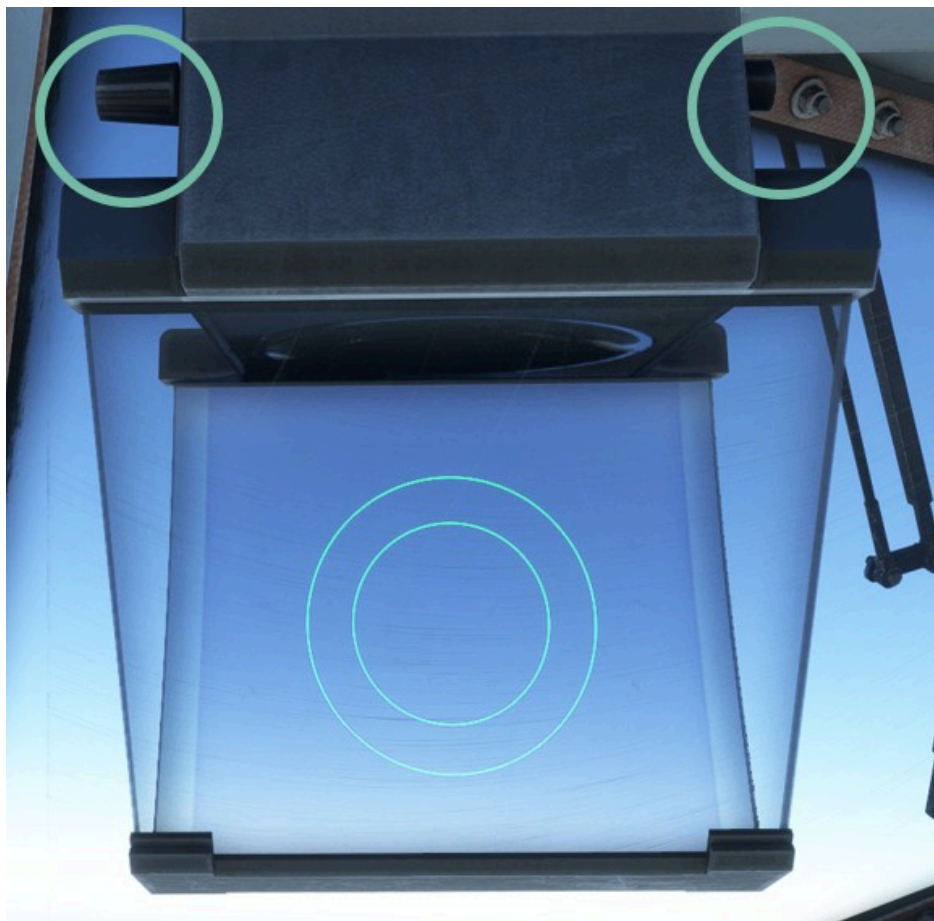

With IRS aligned, the HUD will have the following layout:

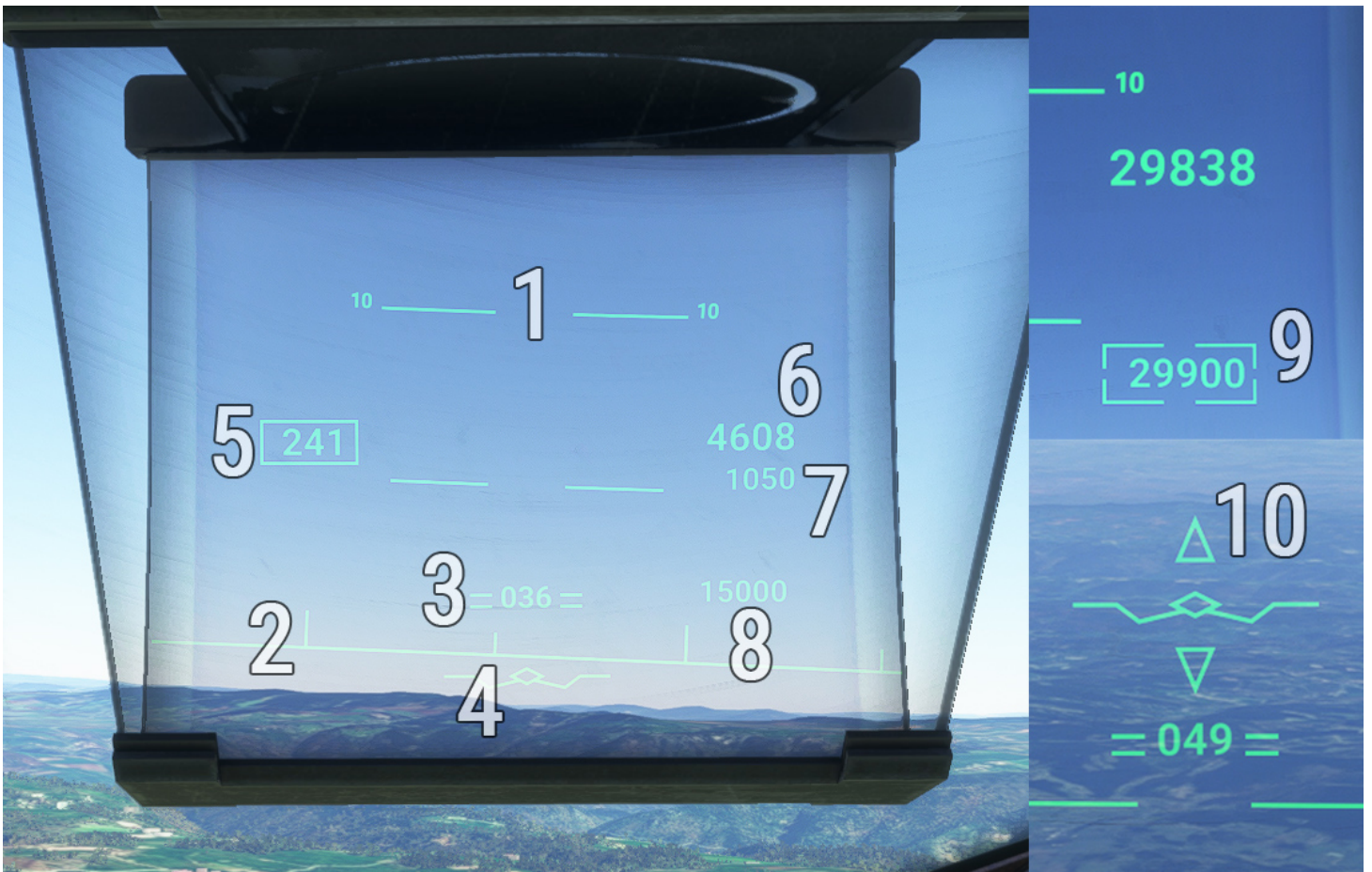

#	Description	#	Description
1	Pitch graduations (for each 5°)	6	Altitude
2	Horizon line (vertical bar for each 5° heading)	7	Radio altitude (displayed below 2500 ft)
3	Pitch attitude indication with current heading	8	Target altitude
4	Flight path vector	9	Captured altitude frame
5	Airspeed	10	ILS glideslope indication (too high/too low)

Flight path vector symbol varies with:

- Autopilot engaged.



- Landing gear down.

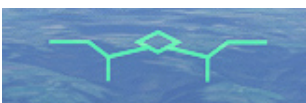

- Spoilers extended.



## IFF / transponder

A complex military Identification Friend or Foe (IFF) is located on center console. For simulation purpose, only mode S (transponder) is implemented, as other military functionalities do not have any usage in the simulator.

Transponder mode (off/standby/on) is switched with the main knob, and current transponder code is changed with the bottom numeric keypad.



## Weather radar

Weather radar enables to locate areas of bad weather during the flight, thanks to a visual indication of areas with high density of clouds. Radar antenna is positioned in aircraft radome (nose) and has a range of 200 nautical miles.

Visualization screen is located in the middle of front panel, and control panel on the bottom of center console.

**NOTE**

Weather radar implementation in MSFS is very basic, hence several functionalities are inoperative.



#	Description	#	Description
1	Power knob (OFF, TEST, STBY, EMISSION)	5	Impulse length (inoperative)
2	Gain knob	6	Gain attenuation (inoperative)
3	Light knob (inoperative)	7	Radar/beacon mode (inoperative)
4	Elevation knob (inoperative)		



#	Description	#	Description
1	Observation mode (inoperative)	5	Visualization (120°, 240°, freeze)
2	Markers display	6	Contrast knob
3	Brightness knob	7	Range knob
4	Sensibility knob (inoperative)		

## BDHI

Bearing Distance Heading Indicator (BDHI) can be used in addition to the EHSI, for similar purpose.

Background rose is rotating to indicate current magnetic heading.

Depending on active radionavigation frequencies and switches position, a single needle and a double needle will indicate the direction of target station. A third needle is dedicated to TACAN station, and indicates an absolute bearing (angle relative to magnetic north) while other needles indicate a relative heading (angle relative to aircraft heading).

When one of the sources is not available, an orange flag is displayed.



#	Description	#	Description
1	Single needle source (ADF/VOR1)	4	Single needle source signal flag
2	Double needle source (VOR2/UHF)	5	Double needle source signal flag

#	Description	#	Description
3	TACAN signal flag	6	TACAN distance

## Ventilation

Ventilation is managed as soon as aircraft is powered.

Depending on systems powered, ventilators disposed in various places will be powered, and their current state is indicated on top console:

- Electronic Attitude Director Indicator (EADI).
- Electronic Horizontal Situation Indicator (EHSI).
- Symbols generating box (BGS).
- Inertial Reference System (IRS).
- Display Processor Unit (DPU).

Last row is composed of red lights that will glow if one of the EADI or EHSI units are overheating.

A button allows to test all the lights of the panel.



## Audio panel

Each crew member has an audio panel to manage sound related to communication and radiocommunication.

Knobs allow to set volume for each audio input: COM, VOR, marker, TACAN, ADF, etc.



**NOTE**

As there is a single sound output in the simulator, those three panels will result to the same changes to sound variables.

# Electronic flight bag

To help managing all actions related to the aircraft, an EFB has been implemented, similarly to all our other aircraft.

Screen luminosity can be set from the top bar.

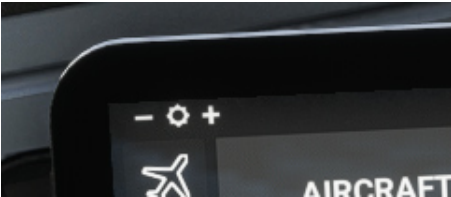

EFB can be closed with a click on its main button, and reopened from a button on front panel.



## Aircraft

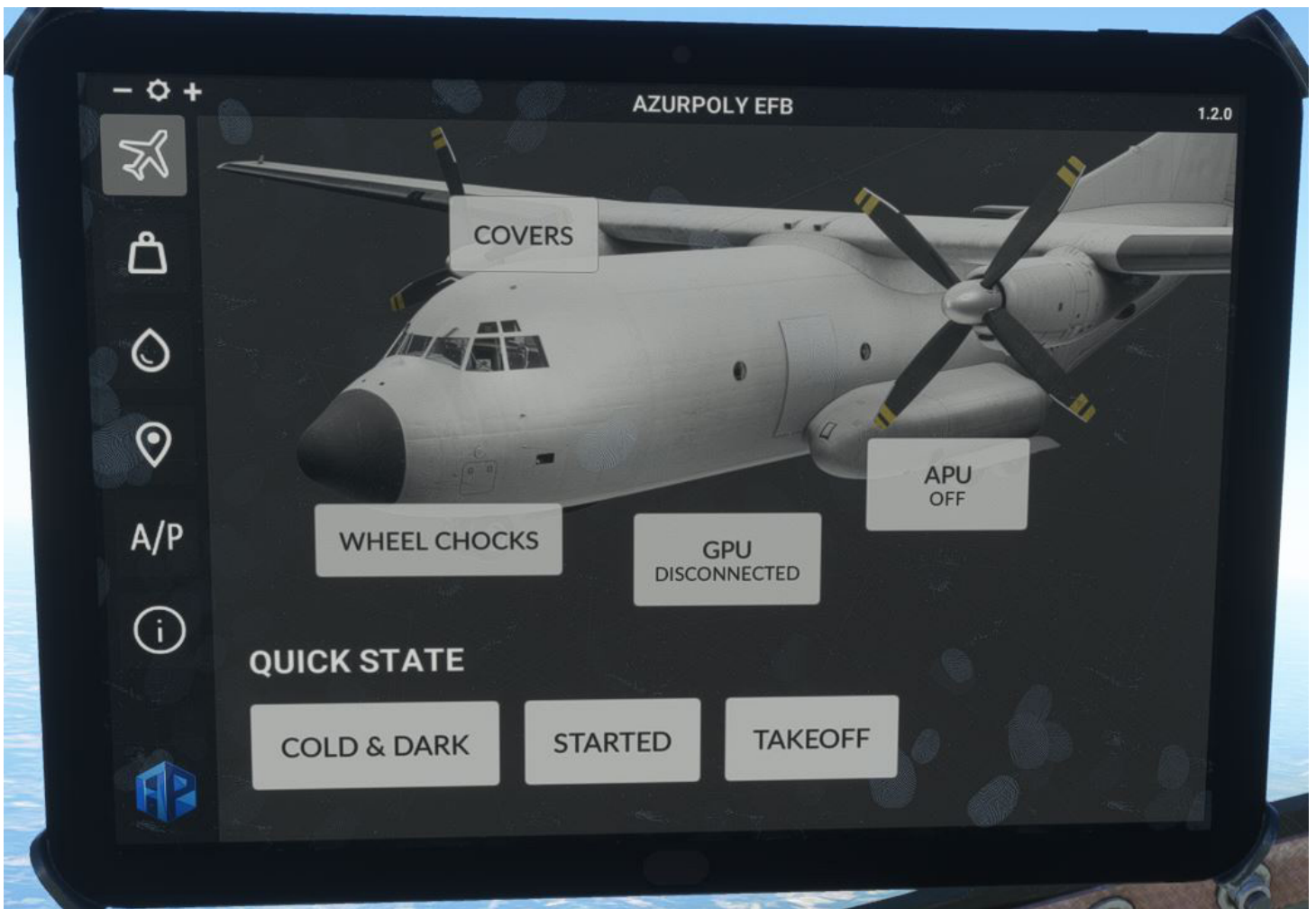

First page covers main functions related to the aircraft:

- APU start and stop.
- GPU connecting and disconnecting.
- Wheel chocks display.
- Aircraft covers display.

To bypass manual actions, pre-defined configuration can be set:

- Cold & dark (all off).
- Aircraft started.
- Takeoff configuration.

As covers are managed **differently**, you will see a QUICK PREFLIGHT button instead. Clicking on this button will auto-complete all preflight actions (remove covers, etc).

A second button allows to display the scissor lift next to left wing.

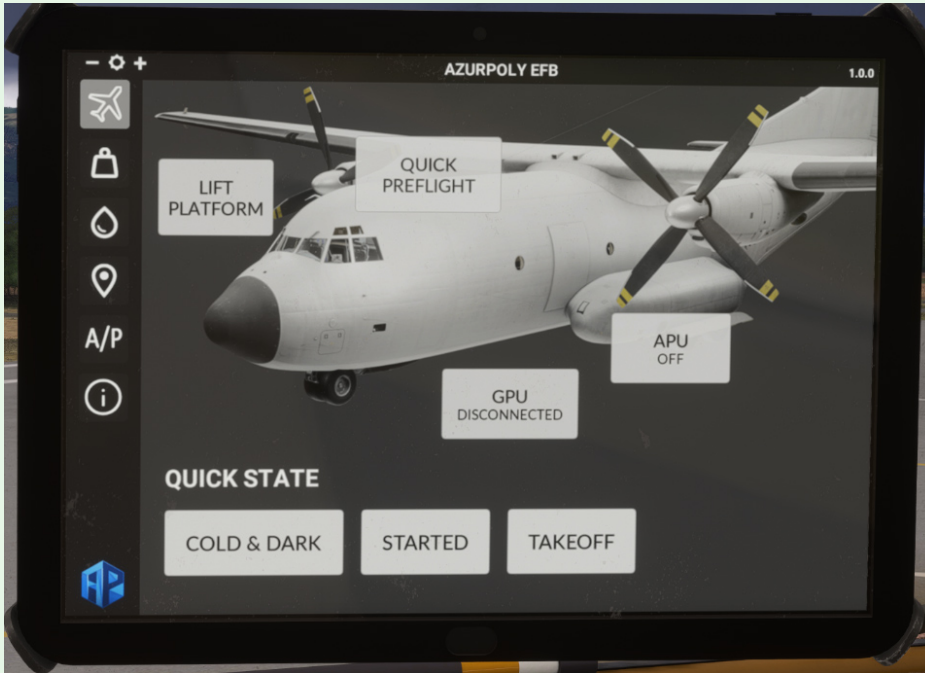

## Payload

This page is mainly related to cargo and doors management.

On left column, several checkboxes for:

- Propeller vortices display.
- Propeller dust display.
- Yoke display.
- Copilot display.
- GPS unit display.
- HUD display (pilot and copilot).
- Disable payload weight syncing with current aircraft weight.

Propeller effects are disabled by default to avoid FPS drop.

Just below, a weight recap is displayed with fuel weight, payload weight and total weight. You can see that maximum weight is easily reached when cargo items are being added, which is one of the weaknesses of the Transall.

Inside aircraft diagram, you can choose between several items to add inside the cargo bay. A preview picture is displayed when hovering above a button, and aircraft weight is updated automatically when an item is added or removed.

Other functions are:

- Door opening and closing when clicking on yellow circles (see [doors](#) section).
- Cargo lights switch button.
- Gear compartment door button.
- Fuse lowering and raising button.
- Flares reloading button.
- Cargo dropping button.



### 💡 MSFS 2024 NATIVE VERSION ONLY

In MSFS 2024, you will observe few differences on this page:

- Propeller dust is managed by the simulator and not optional anymore.
- Copilot display is managed from the **simulator tablet**.
- Various GPS options are available (Working Title GNS 430, PMS50 GTN 650, TDS Sim GTN 650).

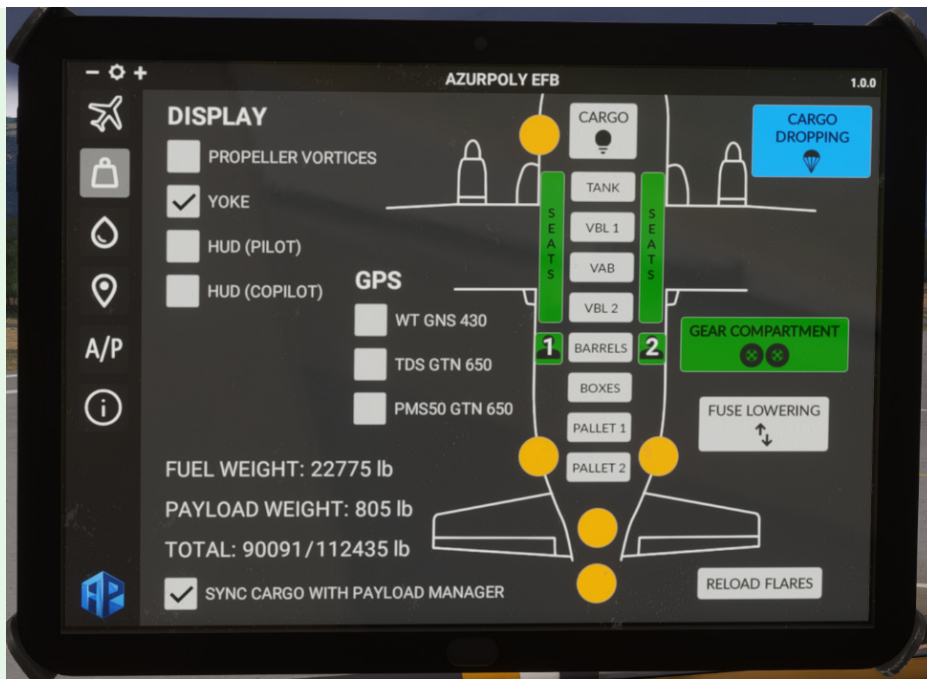

## Fuel

This page shows fuel quantity in each of the six tanks, where you can use sliders to update quantity directly.

You can achieve the same in the default fuel menu.

It also shows current methanol level with a button to refill its tank.

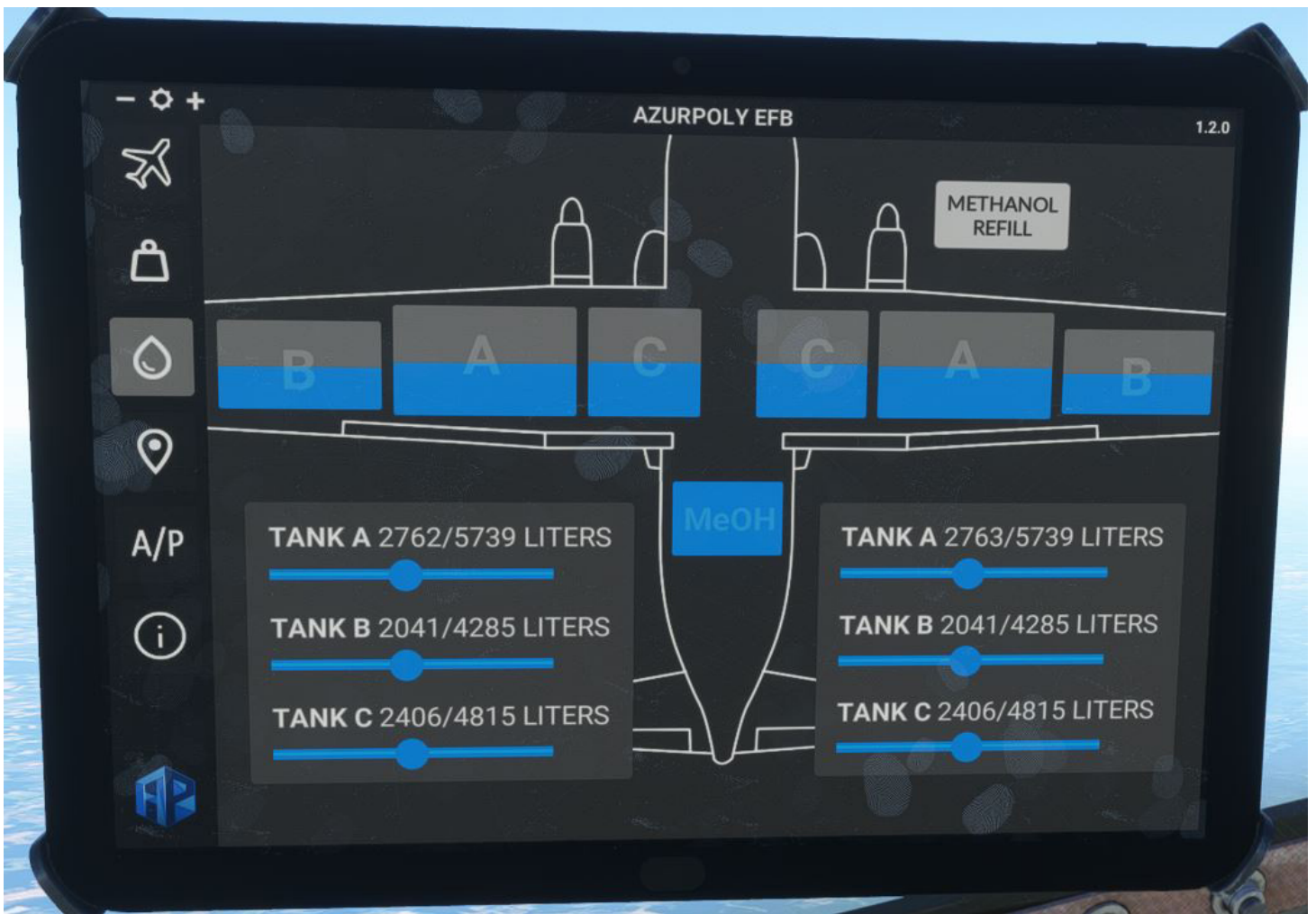

## Map

This menu consists of a map showing current aircraft position.

Different controls on the right part allow to interact with the map:

- Zoom buttons.
- Button to stop auto centering to aircraft position.
- Trajectory button to show or hide aircraft path.



## Autopilot

The aircraft is already fitted with an **autopilot**, however this menu allows an easier usage for simple altitude and heading hold modes. Autopilot will have the exact same behavior when used from the cockpit panel and from the EFB.

When turning ALT or HDG mode on, current altitude/heading will be used by default, and you can change the values with ⊕ and ⊖ buttons.

A precise vertical speed can be maintained during climb/descent with VS button and the target value below.

Once target altitude is reached, VS mode is disabled automatically and ALT mode is enabled. You will need to change target altitude to use VS mode again.



## Information

This menu indicates version of the aircraft currently installed on your machine. A message will be displayed if an update is available.

You can also see your total time spent inside the Transall. For the developers, that's a lot of time!

- ⚙️ +

AZURPOLY EFB

1.2.0



A/P



**FLIGHT TIME:** 251h 37min

**VERSION INFORMATION:**

CURRENTLY INSTALLED: 1.2.0

LATEST AVAILABLE: 1.1.2

**YOU HAVE THE LATEST VERSION**

PLEASE DOWNLOAD THE MANUAL ON [AZURPOLY.COM](http://AZURPOLY.COM)

# Procedures

## Reference speeds

Please note that aircraft weight has a big impact on some reference speeds like stall speed. You may check performance section to compute more precise values depending on flight conditions.

Stall speed (full flaps)	60 kts
Stall speed (no flaps)	72 kts
Rotation speed	110 kts
Initial climb speed	130 kts
Approach speed	110 kts
Best glide speed (no flaps)	110 kts
Maximum speed in turbulent air (VNO)	250 kts
Maximum (full) flaps extended	130 kts
Never exceed speed (VNE)	281 kts
Maneuvering speed (VA)	190 kts

## Checklists

We propose in this section detailed checklists, close to the ones used during real aircraft operation.

In addition to this manual, you can find simplified in-game checklists, with essential steps, dynamic validation and cameras management to help you complete each step.

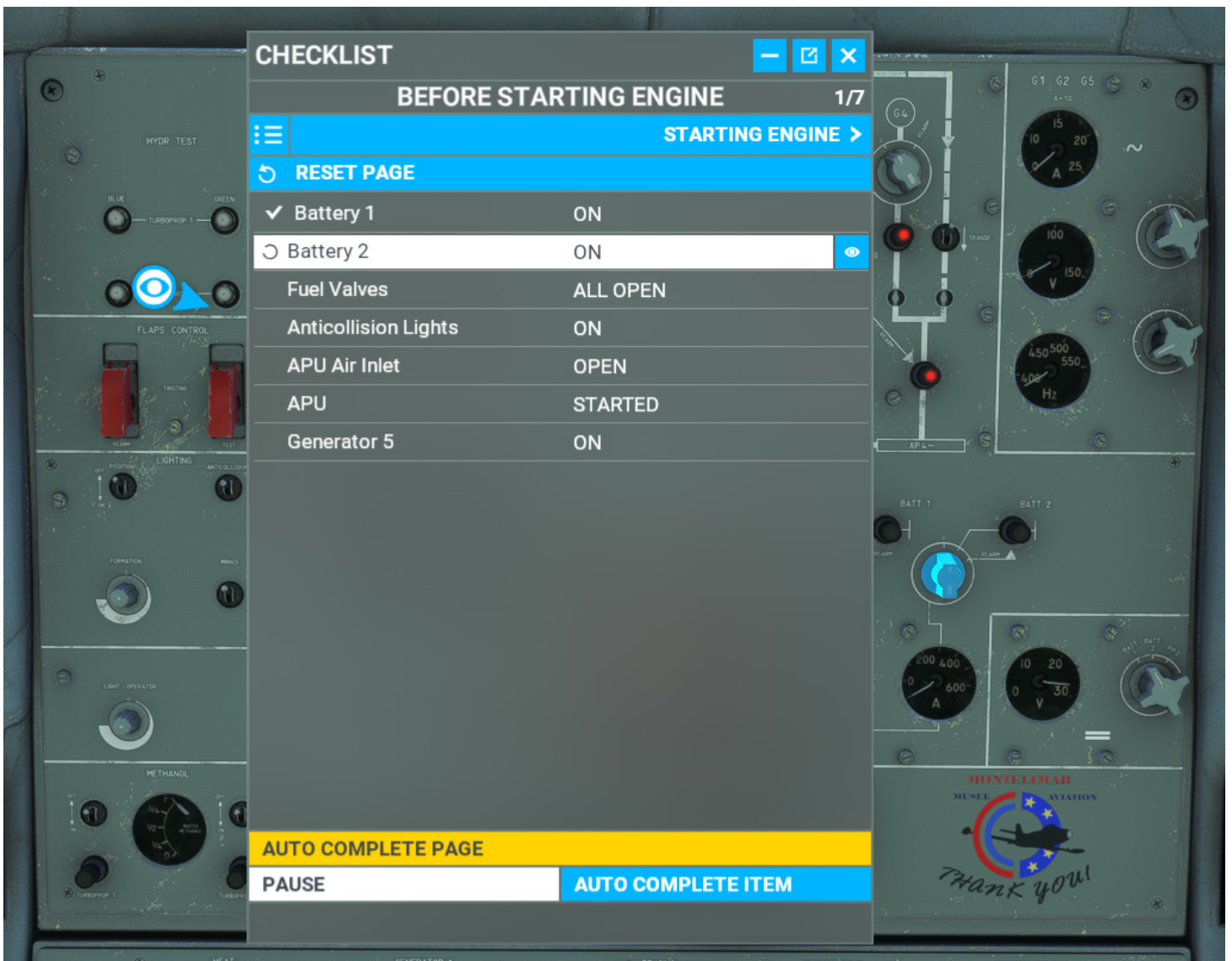

INTERIOR VISIT	
Speed Probes	<b>CHECKED</b>
Angle Of Attack Probe	<b>CHECKED</b>
Icing visual sensor	<b>CHECKED</b>
Refueling Probe Lights	<b>CHECKED</b>
Wipers	<b>GOOD CONDITION</b>
Windshield	<b>CLEAN</b>
Extinguishers	<b>IN PLACE</b>
Accelerometer	<b>NEUTRAL</b>
ELT	<b>AUTO</b>

<b>INTERIOR VISIT</b>	
Ministop (anti-skid)	<b>ON</b>

<b>BEFORE START</b>	
Fuel Valves	<b>OPEN AS NEEDED</b>
Battery 1	<b>ON</b>
Battery 2	<b>ON</b>
Batteries Voltage	<b>CHECKED</b>
Fire Detection System	<b>TESTED</b>
Anticollision Lights	<b>ON</b>
Fuel Burnt Indicators	<b>RESET</b>
APU Air Inlet	<b>OPENED</b>
APU Starter	<b>ON</b>
Red Hydraulic Pressure	<b>CHECKED</b>
Generator 5	<b>ON</b>
Engine Vibration Measure	<b>ON</b>
IRS 1&2	<b>ON</b>
Trims	<b>TESTED</b>
Flight Commands	<b>FREE</b>
Altimeters	<b>CALIBRATED</b>
Fuel Quantity	<b>ANNOUNCED</b>
Water-Methanol Quantity	<b>ANNOUNCED</b>
Fuel Pumps	<b>ON</b>
Fuel Pressure	<b>CHECKED</b>
Air Conditioning Bleed Air Valves	<b>CLOSED x3</b>
Propeller Synchronization	<b>OFF</b>
Propeller Brake	<b>OFF x2</b>
Power Levers	<b>IDLE</b>

<b>BEFORE START</b>	
Condition Levers	<b>CUTOFF</b>
Idle Levers	<b>START</b>
Doors	<b>CLOSED</b>
APU Bleed Air	<b>ON</b>
General Engine Start Switch	<b>ON</b>
Parking Brake	<b>ON</b>
Propellers Area	<b>CLEAR</b>

<b>ENGINE START</b>	
For each engine	
Engine Starter	<b>ON</b>
Low Pressure Tachometer	<b>WAIT FOR 2000 RPM</b>
Condition Lever	<b>LOW IDLE</b>
High Pressure Tachometer	<b>WAIT FOR 3500 RPM</b>
Idle Lever	<b>NORM</b>

<b>AFTER START</b>	
General Engine Start Switch	<b>OFF</b>
Generators	<b>ON x4</b>
Spoilers	<b>TESTED</b>
Flight Commands	<b>FREE</b>
Trims	<b>SET</b>
Hydraulic Pressure	<b>CHECKED</b>
Taxi Light	<b>ON</b>

<b>TAXI</b>	
Chronometer	<b>STARTED</b>

<b>TAXI</b>	
Brakes	<b>TESTED</b>
Anti-Ice Systems	<b>AS NEEDED</b>
Flight Instruments	<b>CHECKED</b>

<b>BEFORE TAKEOFF</b>	
APU & Generator 5	<b>AS NEEDED</b>
Yellow Hydraulic Pump	<b>AUTO</b>
Fuel Dump Valve	<b>CLOSED</b>
Fuel Pressure	<b>CHECKED</b>
Flaps	<b>AS NEEDED</b>
Flight Commands	<b>FREE</b>
Doors	<b>CLOSED</b>
Condition Levers	<b>HIGH IDLE</b>

<b>LINEUP</b>	
Landing Lights	<b>ON</b>
Taxi Light	<b>RETRACTED</b>
Water-Methanol Pumps	<b>AS NEEDED</b>
Pitot Heat	<b>ON</b>
Angle Of Attack Sensor Heat	<b>ON</b>
Windshield Heating	<b>AS NEEDED</b>
Fuel Pumps	<b>CHECKED</b>
Alarms	<b>ALL OFF</b>

<b>TAKEOFF</b>	
Power Levers	<b>FULL FORWARD</b>
Parameters	<b>NOMINAL</b>

<b>TAKEOFF</b>	
V1/V2/VR	<b>ANNOUNCED</b>

<b>AFTER TAKEOFF</b>	
Variometer	<b>POSITIVE CLIMB</b>
Landing Gear	<b>UP</b>
Flaps	<b>UP</b>
Anti-Ice Systems	<b>AS NEEDED</b>
Fuel Pumps	<b>AS NEEDED</b>
Landing Lights	<b>OFF</b>
Water-Methanol Pumps	<b>OFF</b>
Air Conditioning Bleed Air Valves	<b>OPENED x2</b>

<b>CRUISE</b>	
Anti-Ice Systems	<b>AS NEEDED</b>
Fuel Pumps	<b>AS NEEDED</b>
Propeller Synchronization	<b>ON</b>

<b>DESCENT</b>	
Anti-Ice Systems	<b>AS NEEDED</b>
Propeller Synchronization	<b>OFF</b>
Pressurization Settings	<b>CHECKED</b>
Decision Height	<b>SET</b>
Parking Brake	<b>FREE</b>

<b>APPROACH</b>	
Flaps	<b>AS NEEDED</b>

<b>APPROACH</b>	
Landing Gear	<b>DOWN</b>
Landing Lights	<b>ON</b>
Fuel Pumps	<b>ON</b>
Air Conditioning Bleed Air Valves	<b>CLOSED x2</b>

<b>AFTER LANDING</b>	
Anti-Ice Systems	<b>ALL OFF</b>
Taxi Light	<b>ON</b>
Landing Lights	<b>OFF</b>
Flaps	<b>UP</b>
Spoilers	<b>RETRACTED</b>
Trims	<b>NEUTRAL</b>
Front Fuel Pumps	<b>OFF x4</b>
Yellow Hydraulic Pump	<b>OFF</b>

<b>SHUTDOWN</b>	
Air Conditioning Bleed Air Valves	<b>CLOSED x3</b>
Parking Brake	<b>ON</b>
Taxi Light	<b>OFF</b>
Engine Vibration Measure	<b>OFF</b>
Fuel Pumps	<b>OFF x8</b>
Condition Levers	<b>CUTOFF</b>
Anticollision Lights	<b>OFF</b>
Propeller Brake	<b>AS NEEDED</b>
Batteries	<b>OFF x2</b>
Wheel Chocks	<b>IN POSITION</b>

# Startup & shutdown

The Transall is normally operated by four crew members at least. However, you can totally operate our aircraft by yourself in the simulator, thanks to procedures detailed in this section.

A quick tutorial [video](#) shows how to start and stop the aircraft.

# Performance

## Speed tables

To keep a safety margin at any moment of the flight with stall speed ( $V_S$ ), a specific speed called "reference speed" ( $V_{REF}$ ) must be respected at any time.  $V_{REF}$  depends on three factors:

- Aircraft weight.
- Flaps angle.
- Load factor.

As those factors are all changing continuously, the following simple calculation is used for reference speed:

$V_{REF} = 1.3 \times V_{S\alpha 30^\circ}$  where  $V_{S\alpha 30^\circ}$  is the stall speed with flaps  $30^\circ$  and landing gear down.

Here is the table specifying normal operating speeds for any weight:

- Takeoff speeds ( $V_2$  and  $V_R$ ) with flaps  $10^\circ$  and  $20^\circ$ .
- Approach speed ( $V_{APP}$ ) with different flaps settings ( $V_{REF}$  corresponds to flaps  $30^\circ$ ).
- Stall speed ( $V_S$ ) with each flaps setting.

	TAKEOFF				LANDING				STALL				
	$\alpha 10^\circ$		$\alpha 20^\circ$		$\alpha 0^\circ$	$\alpha 20^\circ$	$\alpha 30^\circ$	$\alpha 40^\circ$	$\alpha 0^\circ$	$\alpha 10^\circ$	$\alpha 20^\circ$	$\alpha 30^\circ$	$\alpha 40^\circ$
Weight (tons)	$V_R$	$V_2$	$V_R$	$V_2$	$V_{APP}$				$V_S$				
30	96	98	89	92	111	95	91	88	85	78	73	70	67
31	97	100	91	93	112	97	92	89	87	80	74	71	68
32	99	101	92	95	115	98	94	91	88	81	76	72	69
33	100	103	94	96	116	100	95	92	90	82	77	73	70
34	102	104	95	97	118	101	97	94	91	83	78	74	72
35	103	106	96	99	120	103	98	95	92	85	79	75	73
36	105	107	98	100	122	104	100	96	94	86	80	76	74

	TAKEOFF				LANDING				STALL				
37	106	109	99	101	124	106	101	98	95	87	81	78	75
38	108	110	100	103	125	107	102	99	96	88	82	79	76
39	109	112	102	104	127	108	104	100	98	89	83	80	77
40	110	113	103	105	129	110	105	102	99	91	84	81	78
41	112	115	104	107	130	111	106	103	100	92	86	82	79
42	113	116	105	108	132	113	107	104	101	93	87	83	80
43	115	117	107	109	133	114	109	105	102	94	88	84	81
44	116	119	108	111	135	115	110	107	104	95	89	85	81
45	117	120	109	112	136	117	111	108	105	96	90	86	82
46	118	121	110	113	137	118	113	109	106	97	91	86	83
47	120	123	112	114	139	119	114	110	107	98	92	87	84
48	121	124	113	115	140	120	115		108	99	92	88	
49	122	125	114	117	142	122	116		109	100	93	89	
50		126		118	143	123	117		110	101	94	90	
51		127		119	144	124	118		111	102	95	91	

Related notes:

- When approaching with 40% spoilers, you should increase  $V_{APP}$  by 5 knots.
- Takeoff with a weight above 49.150 tons is allowed only with 0° flaps.
- Stall speed increases with load factor (and hence roll angle): 8% for 30°, 19% for 45°, 40% for 60°.

## Takeoff

Following charts indicate normal takeoff speed and distance with 20 degrees of flaps.

Takeoff distance includes horizontal distance required to take-off plus climb to a 50 feet clearance height.

Takeoff is performed with full throttle; illustration covers use and non-use of water-methanol injection system.

# TAKE-OFF ASSOCIATED SPEEDS - $\alpha H = 20^\circ$

C.A.S.  
(kt)

**Example**

Take-off weight = 45000 kg  
 $V_R = 108,9$  kt  
 $V_2 = 111,7$  kt  
"En route" speed = 130,6 kt

$V$  "en route" =  $1,25 V_S$

130

120

110

100

$V_2 = 1,25 V_S$

$V_R = 1,22 V_S$

Aircraft weight  $G$  (kg x 1000)

35

40

45

50

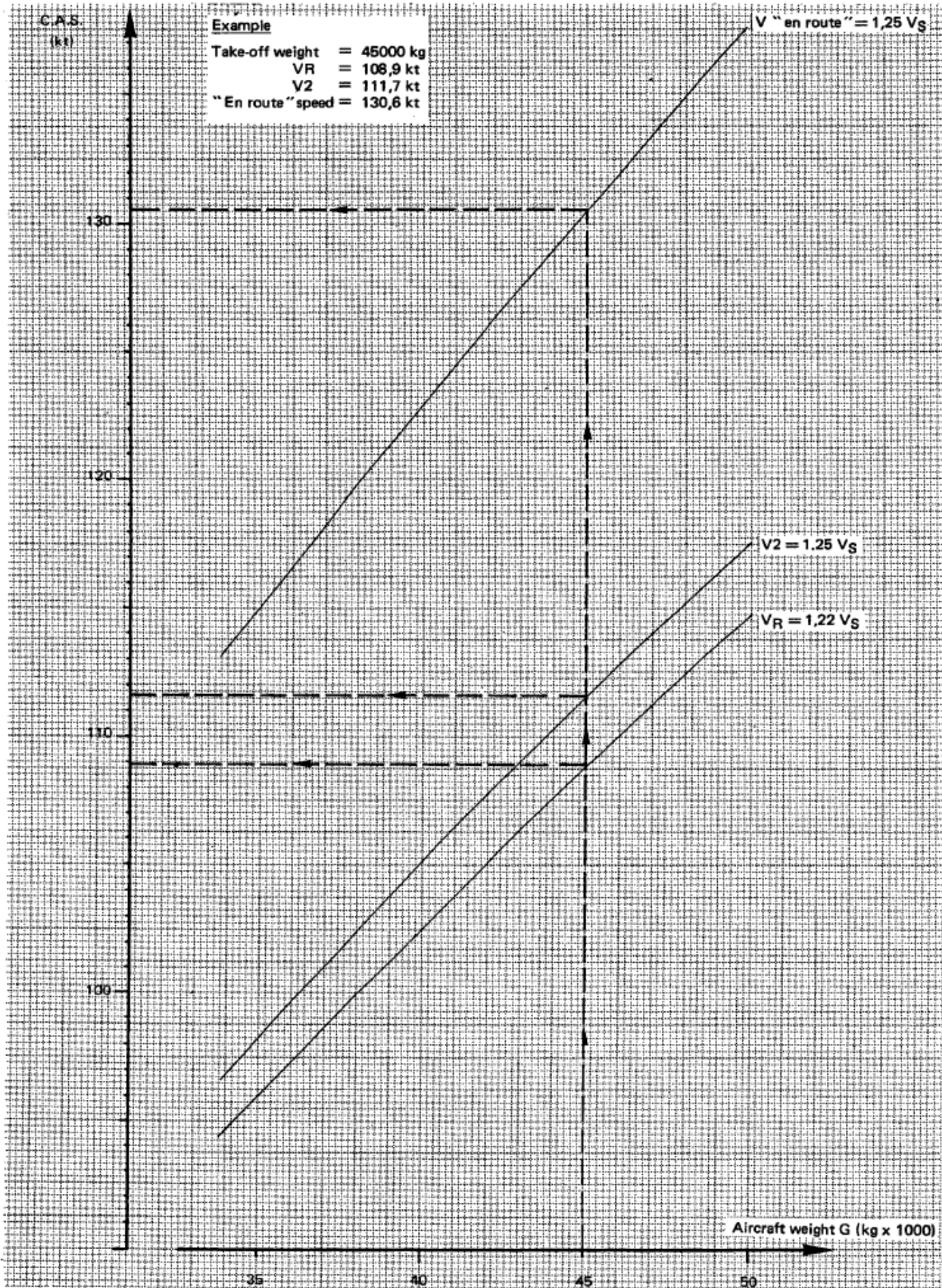

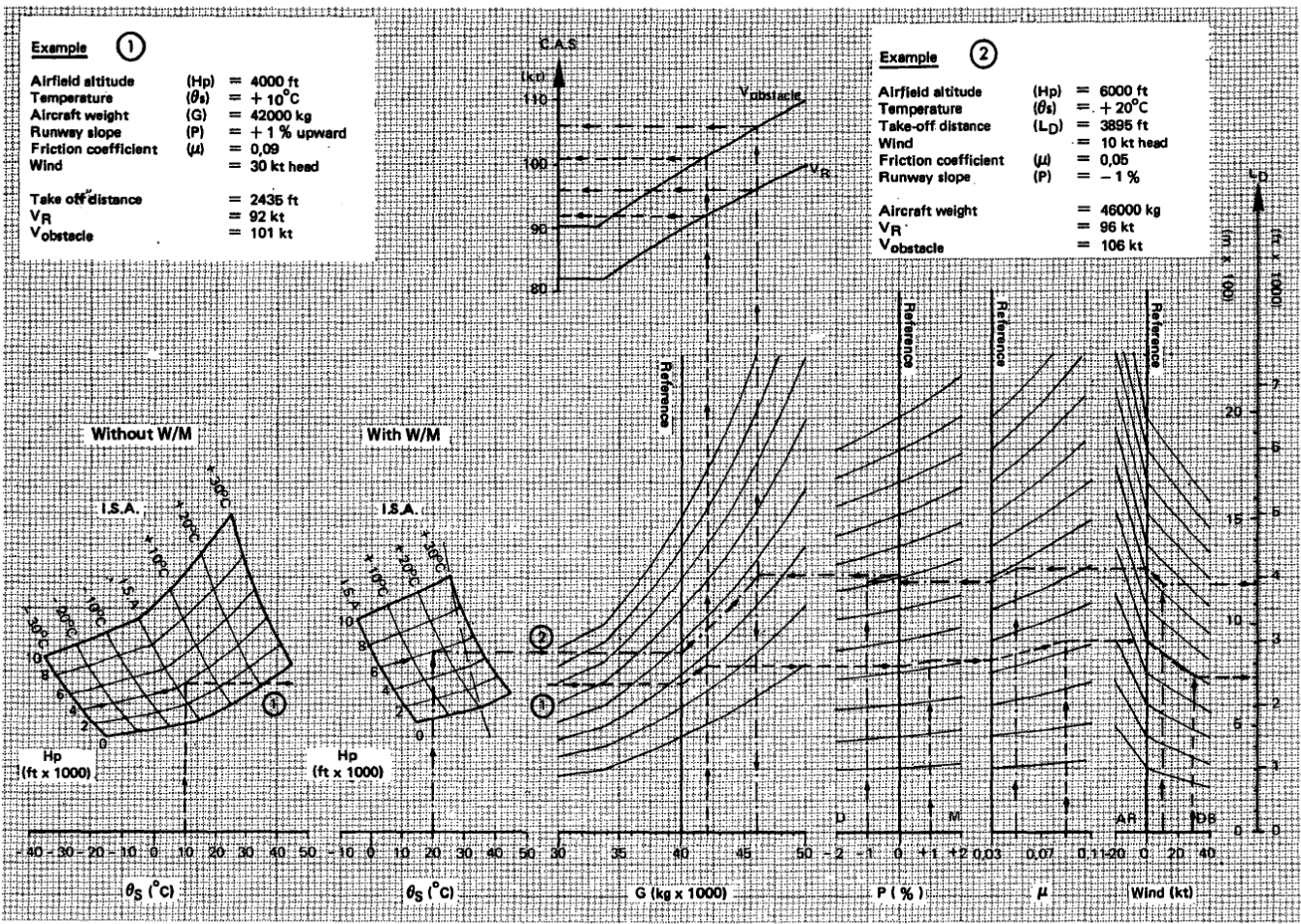

During aircraft operation, a "take-off card" is placed in the field of view of the full crew, gathering essential information for the take-off.





# MAXIMUM CLIMB SPEED With and without air bleed - $V_Z = \max.$

2. RTy 20 Mk522 turboprop engines - Minimum guaranteed performances

$N = 13500 \text{ rpm}$

Altitude Hp  
(ft x 1000)

For  $\theta < \text{I.S.A.}$  keep same C.A.S.  
For  $\theta > \text{I.S.A.}$  decrease C.A.S. by 2 kt per  $10^\circ\text{C}$

Aircraft weight G (kg x 1000)

### Example

$\theta = \text{I.S.A.} + 5^\circ\text{C}$   
Hp = 20000 ft  
C.A.S. = 137,5 kt

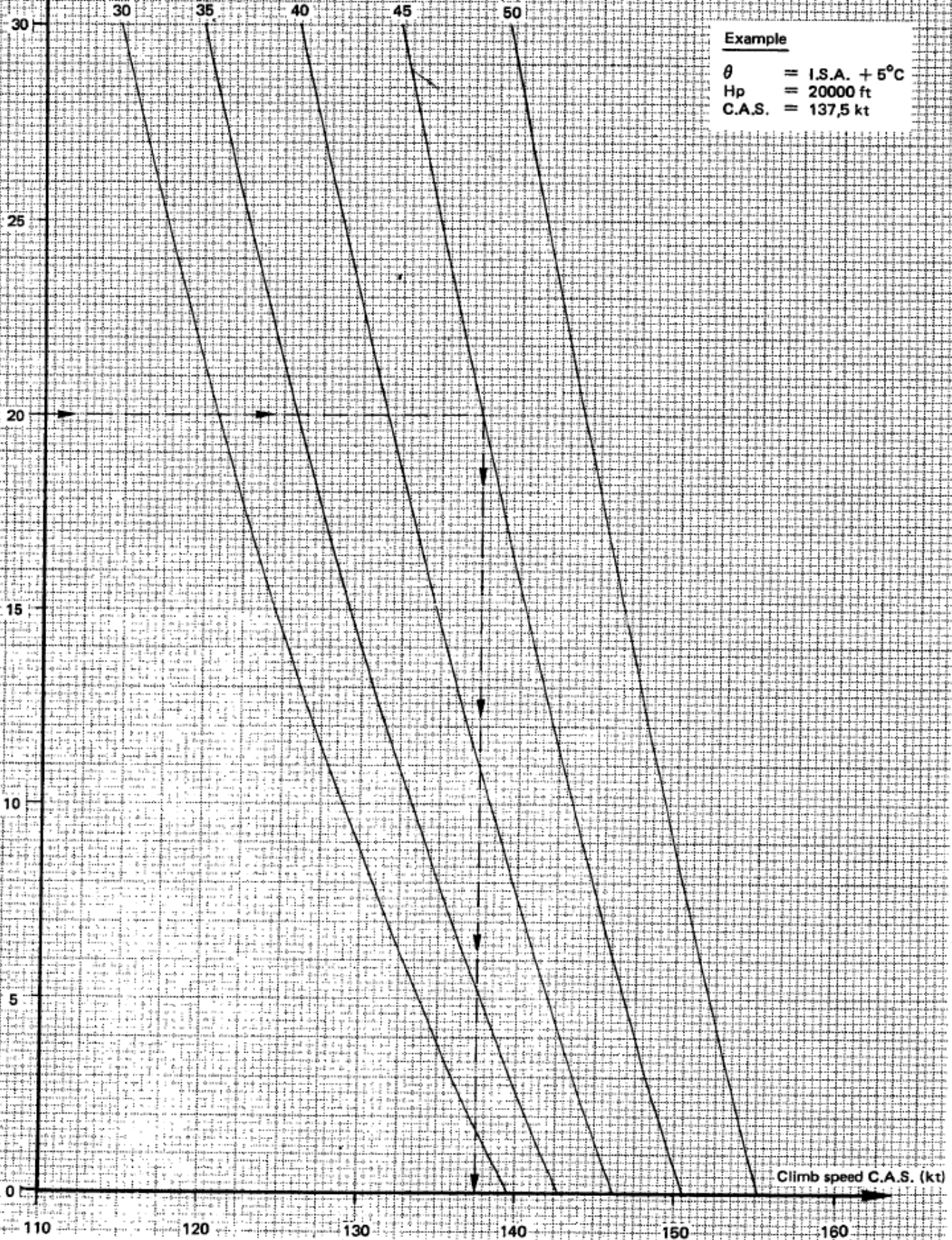

# Cruise

Each following chart corresponds to a given altitude.

It shows true airspeed and fuel consumption for various N1 values, with air bleed.

**LEVEL FLIGHT** With air-bleed –  $H_p = 0$  ft  
 2. RTy 20 Mk522 turboprop engines – Minimum guaranteed performance

T.G.T. limit

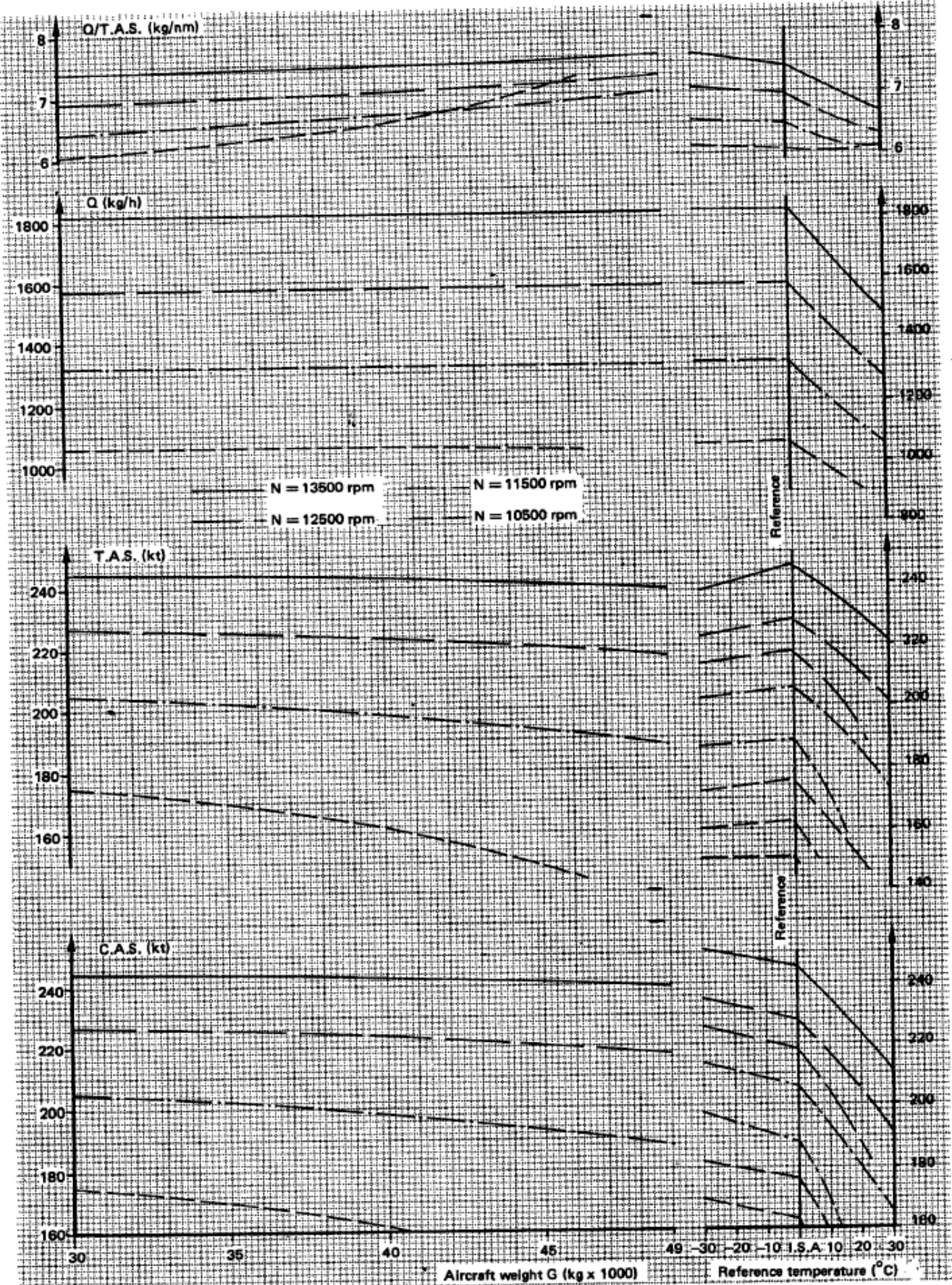

**LEVEL FLIGHT With air-bleed -  $H_p = 5000$  ft.**

2. RTy 20 Mk522 turboprop engines - Minimum guaranteed performances

T.G.T. limit

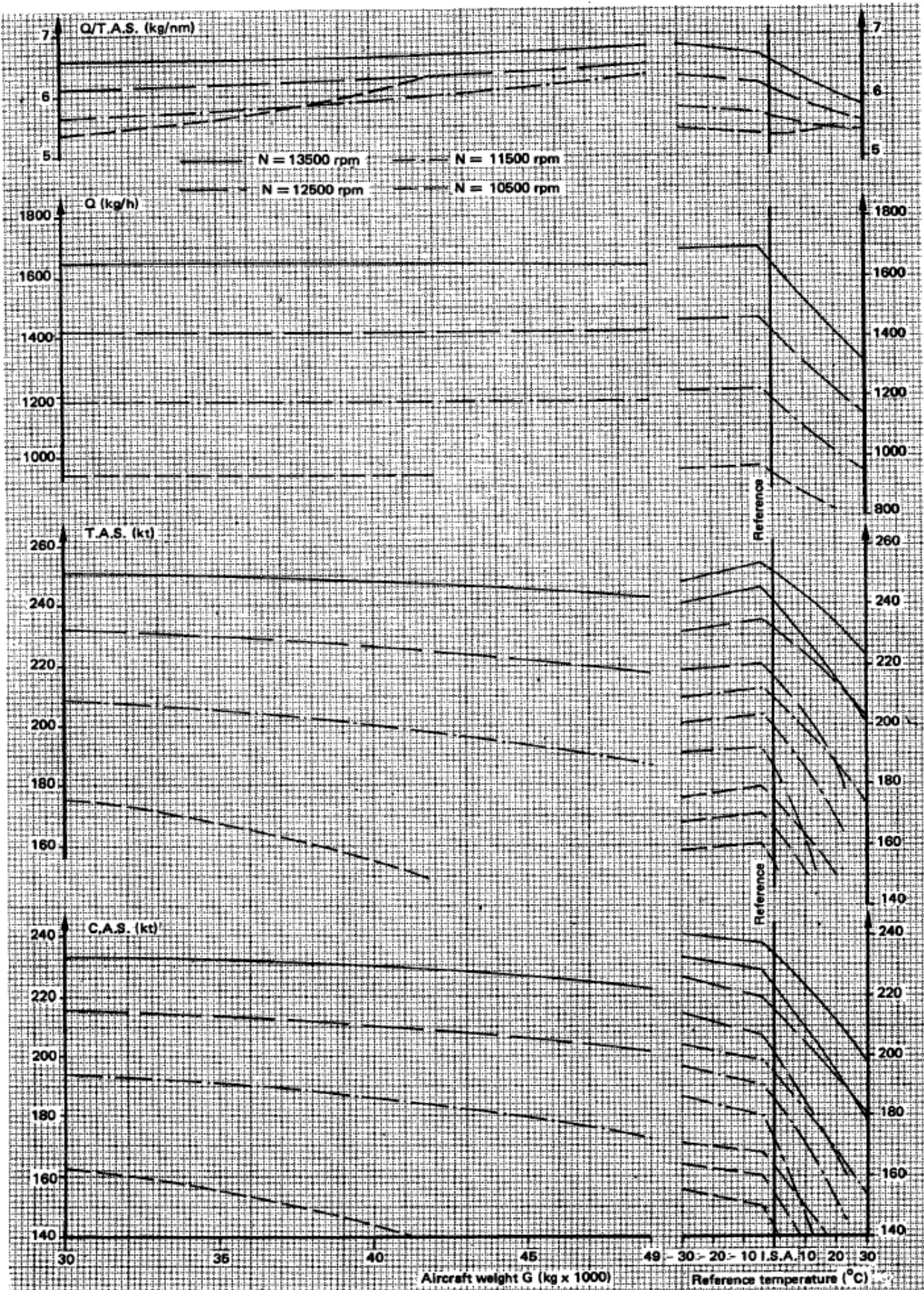

**LEVEL FLIGHT With air-bleed – Hp = 10000 ft**

2. RTy 20 Mk522 turboprop engines – Minimum guaranteed performance

T.G.T. limit

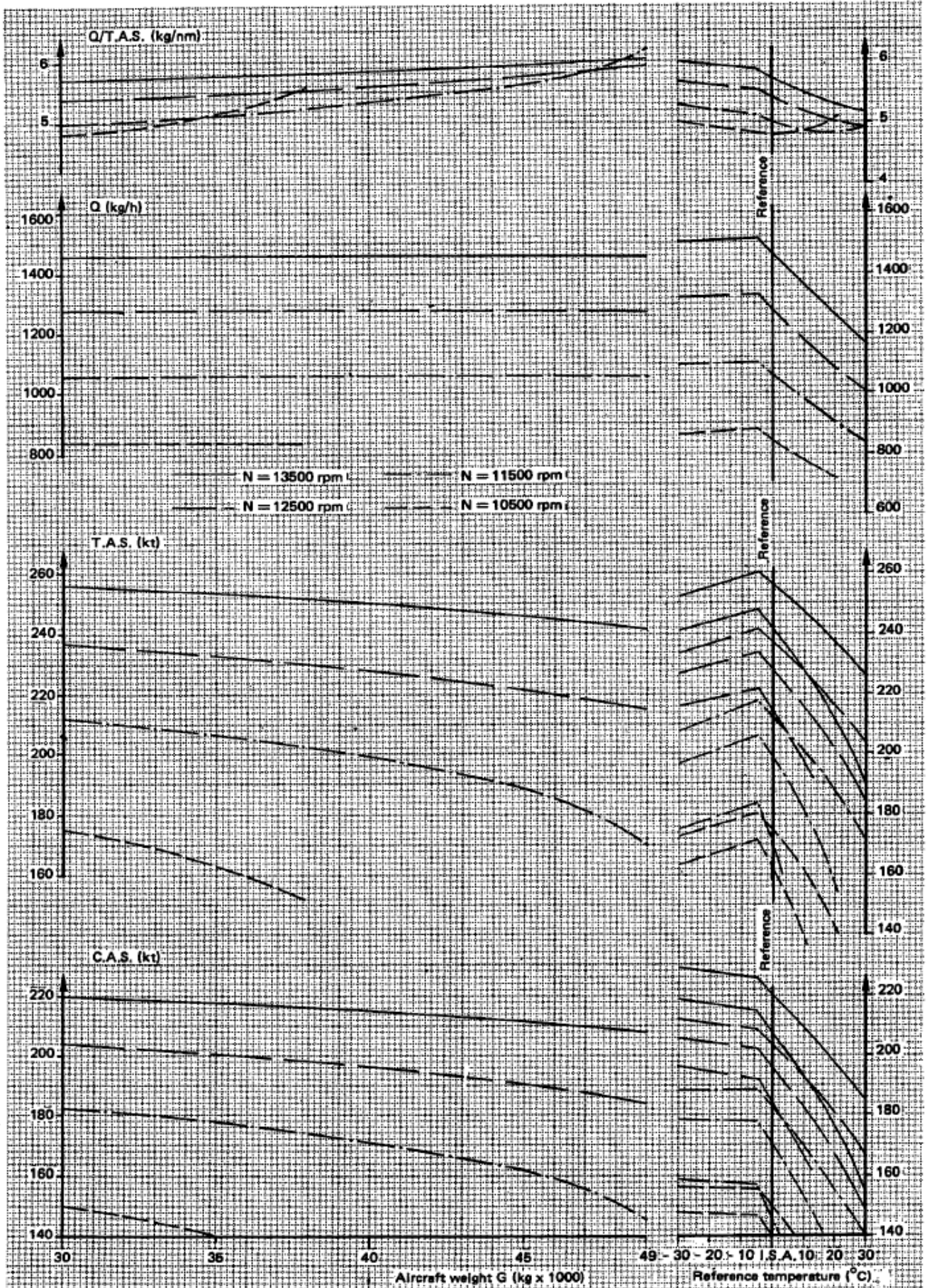

**LEVEL FLIGHT With air-bleed -  $H_p = 16000$  ft.**  
**2. RTy 20 Mk522 turboprop engines - Minimum guaranteed performance**

T.G.T. limit

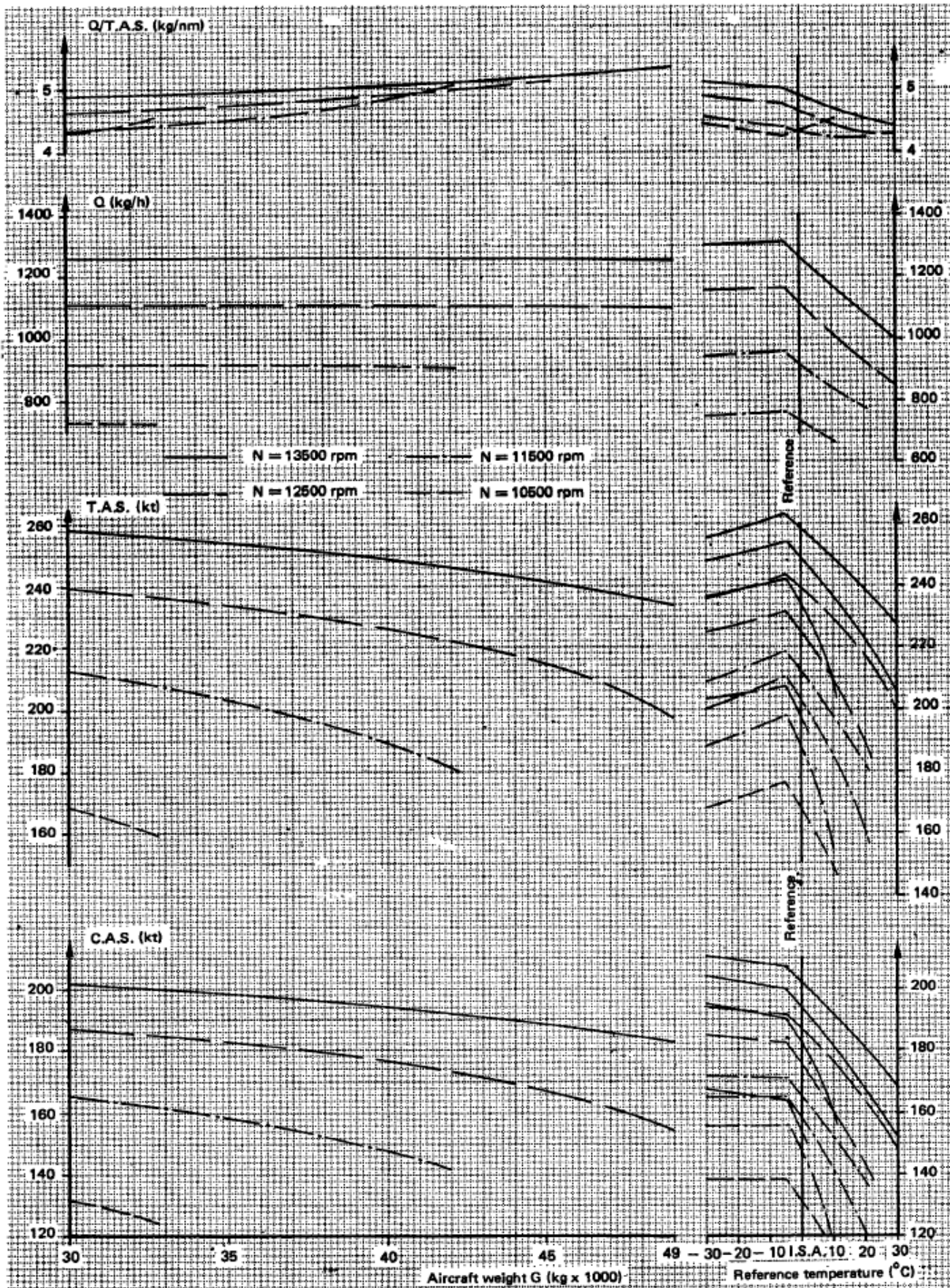

**LEVEL FLIGHT With air-bleed -  $H_p = 20000$  ft.**  
 2. RTy 20 Mk522 turboprop engines - Minimum guaranteed performance

**T.G.T. limit**

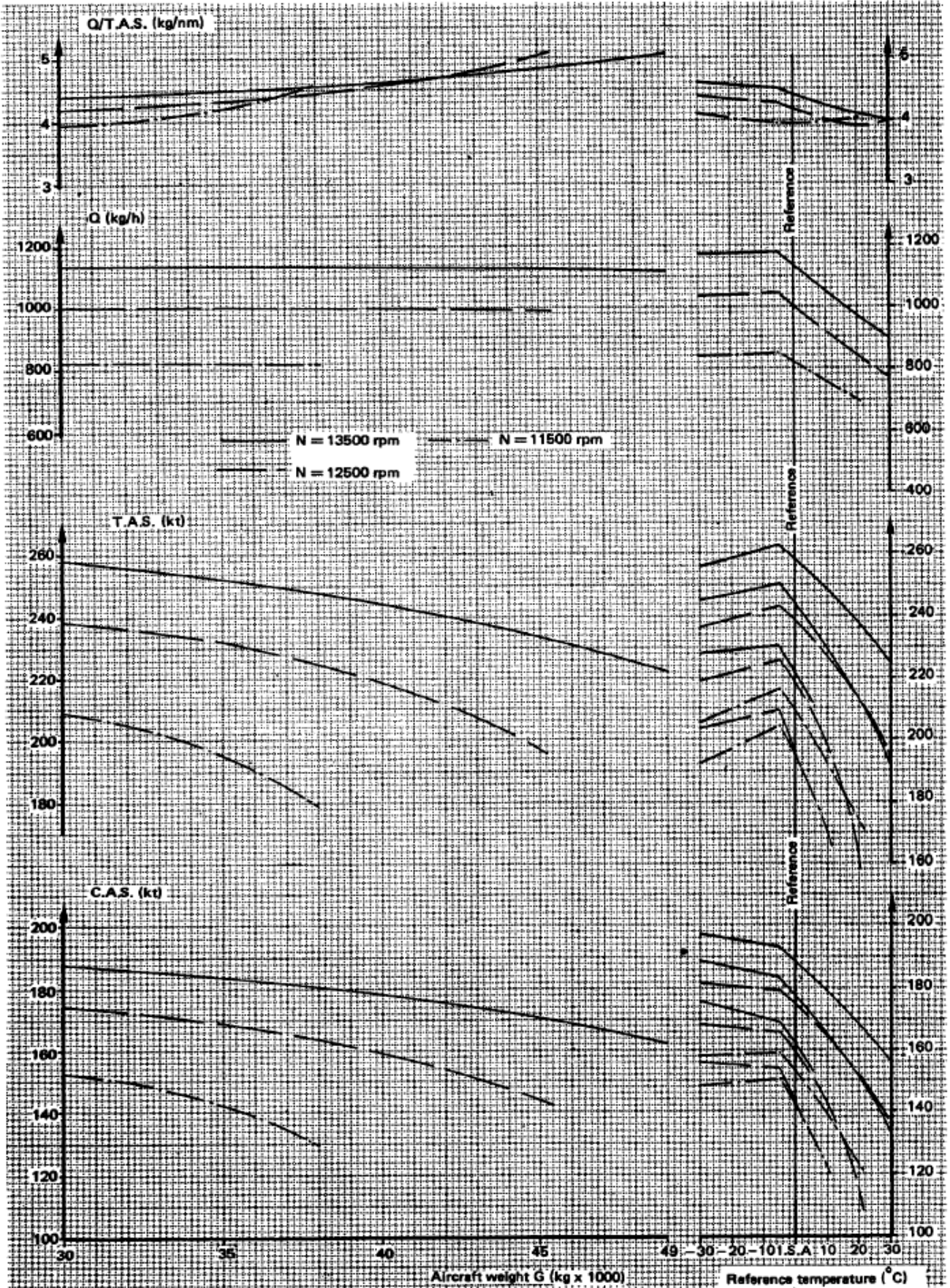

# Descent

Two types of descents are presented in following charts:

- Normal descent with airbrakes retracted.
- Rapid descent with airbrakes extended.

In both cases, a speed of 180 knots is targeted.

**NORMAL DESCENT** Airbrakes retracted | Reduced engine power | I.S.A. - C.A.S. = 180 kt  
 2. RTy 20 Mk522 turboprop engines - Minimum guaranteed performance

N = 10500 rpm

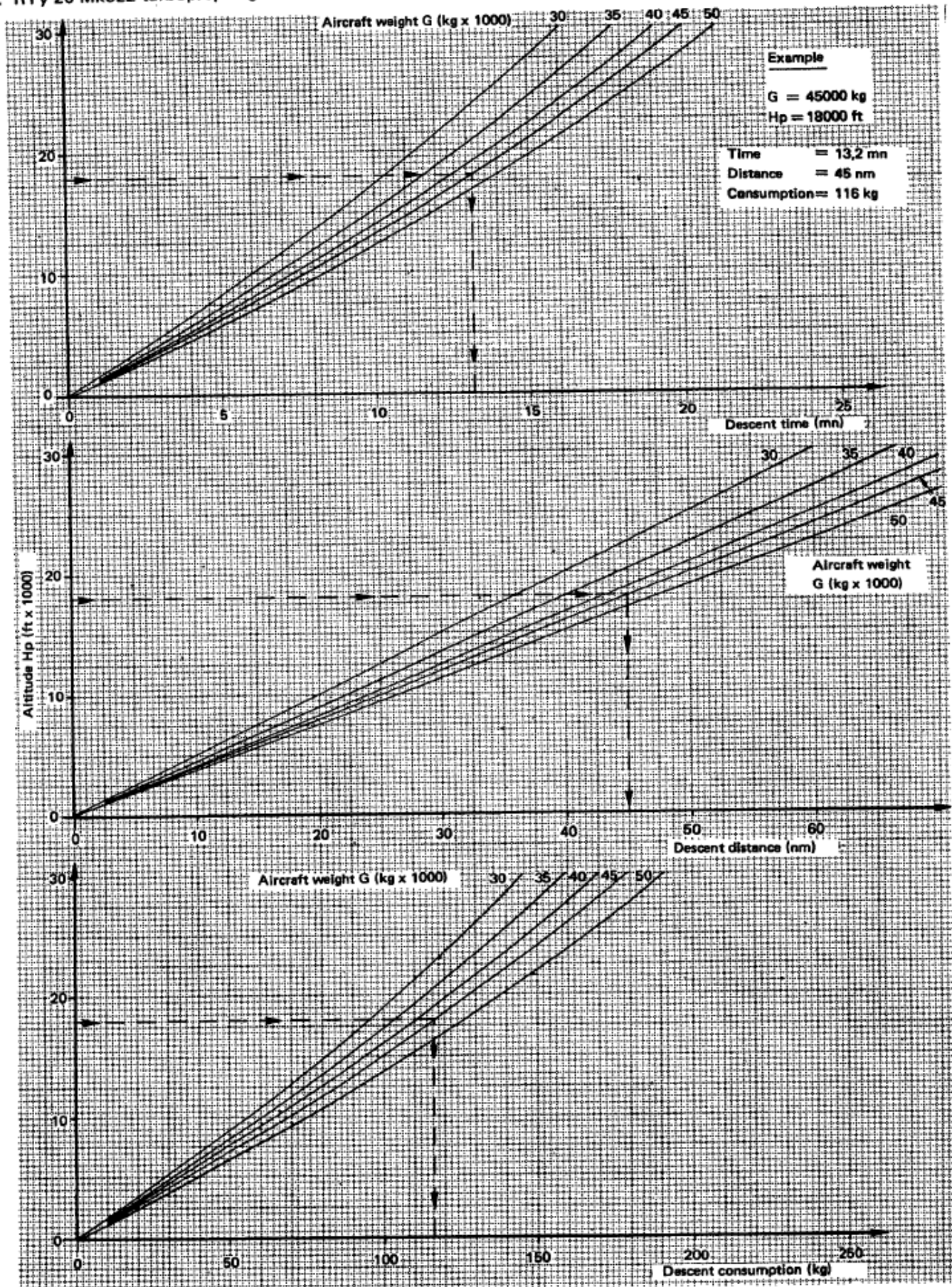

**RAPID DESCENT** Airbrakes fully extended – Reduced engine power – I.S.A. – C.A.S. = 180 kt  
 2. RTy 20 Mk522 turboprop engines – Minimum guaranteed performance N = 10500 rpm

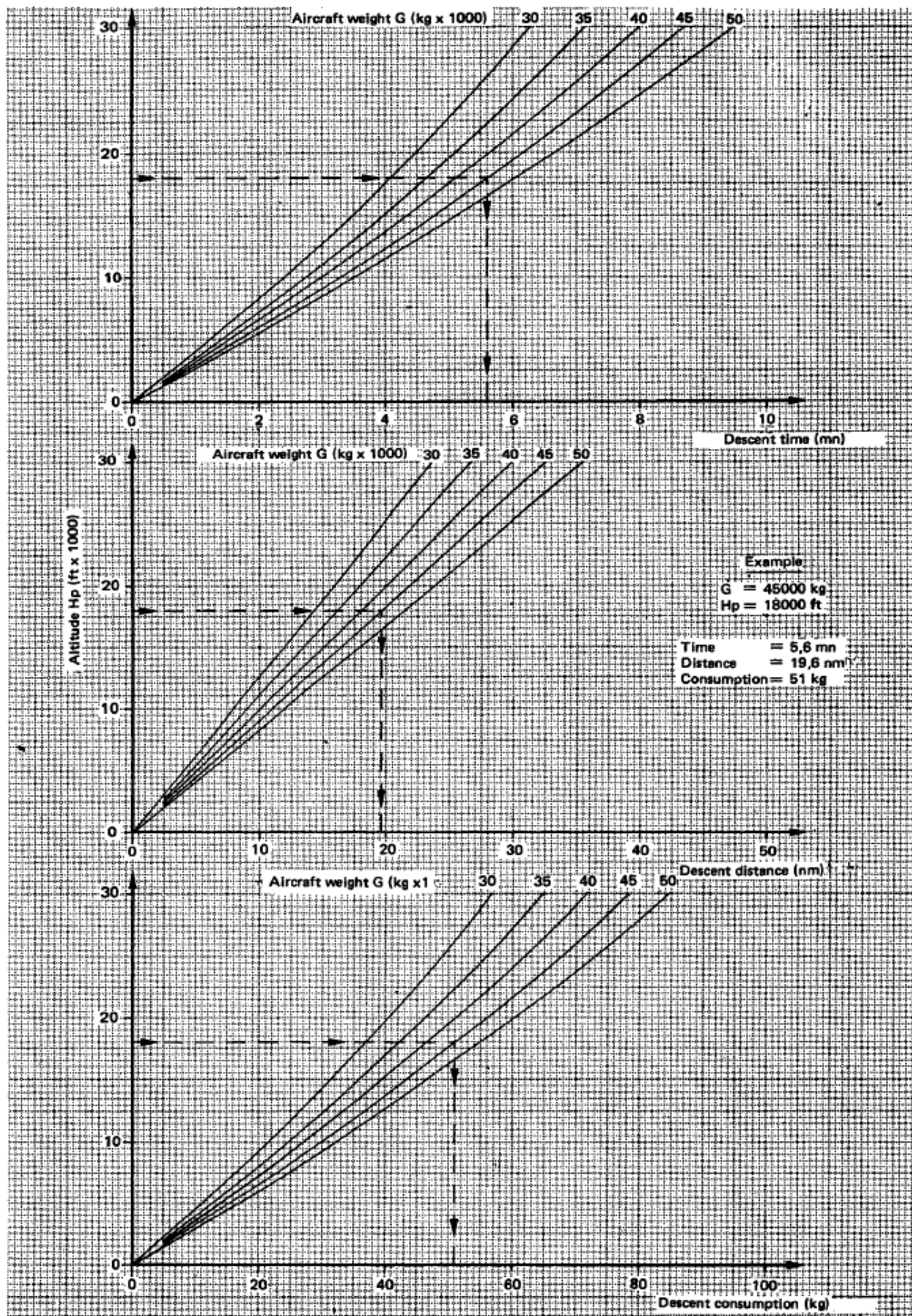

# Landing

Following charts indicate normal landing speed and distance with different flaps settings.

Two scenarios are provided:

- Normal landing without airbrakes (A/B) and without reverse.
- Short field landing with 40% airbrakes and reverse.

# LANDING SPEEDS

## Example

Aircraft weight = 41000 kg  
 Configuration =  $\alpha H = 30^\circ - A/B = 0\%$

Final approach = 106 kt  
 Touch down = 98 kt

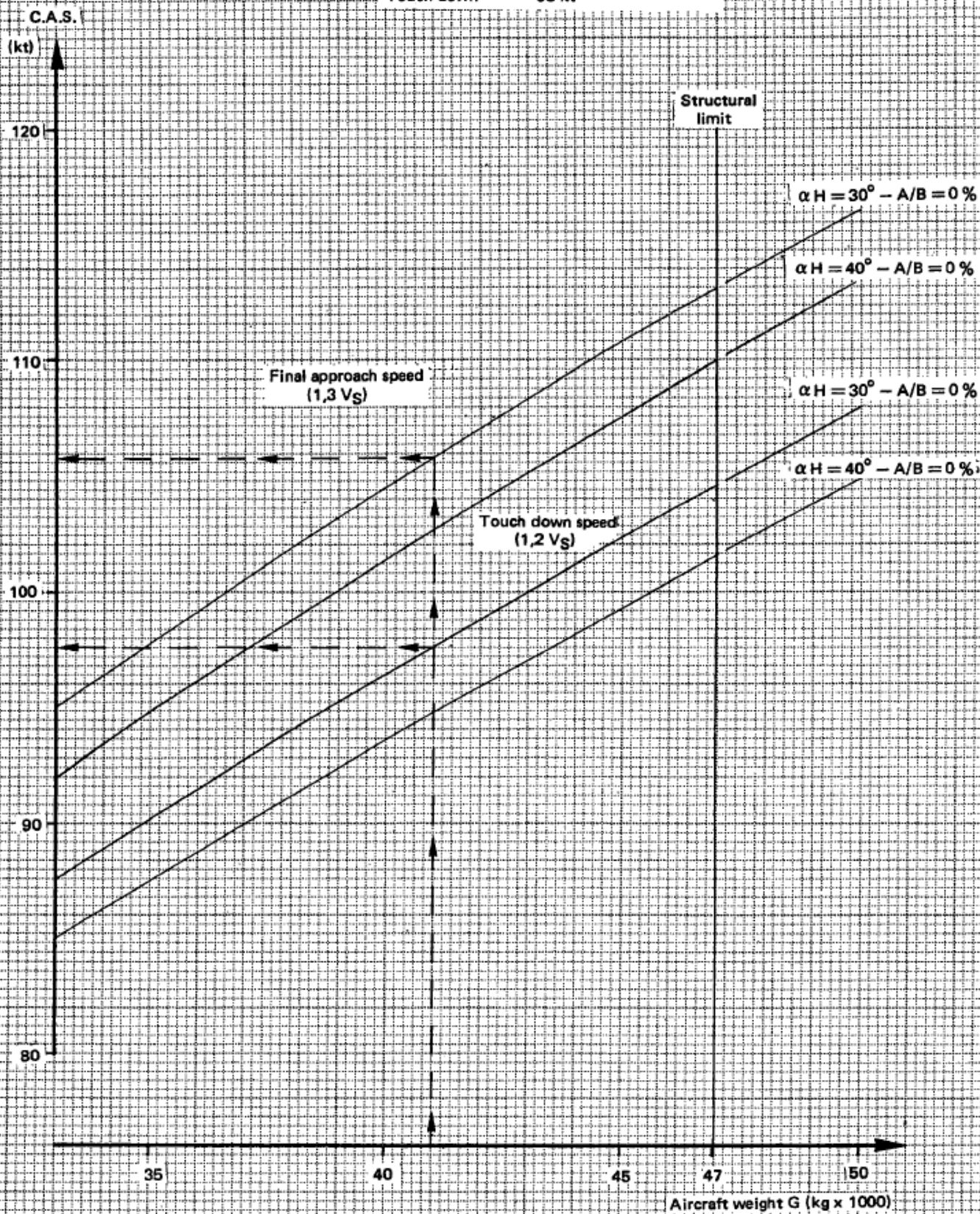

**LANDING DISTANCE** Without propeller reverse pitch  
 $\alpha H = 30^\circ$  and  $40^\circ - A/B = 0\%$

**Example**

- $\theta_S = +5^\circ C$
- $H_p = 4000$  ft
- $\alpha H = 30^\circ$  or  $40^\circ$
- $G = 35000$  kg
- $P = +1\%$  upward
- Wind = 20 kt head

	$\alpha H = 30^\circ$	$\alpha H = 40^\circ$
Diversion runway length	2930 ft	2680 ft
Destination runway length	3320 ft	3060 ft
Approach speed $v$	97.4 kt	84.9 kt

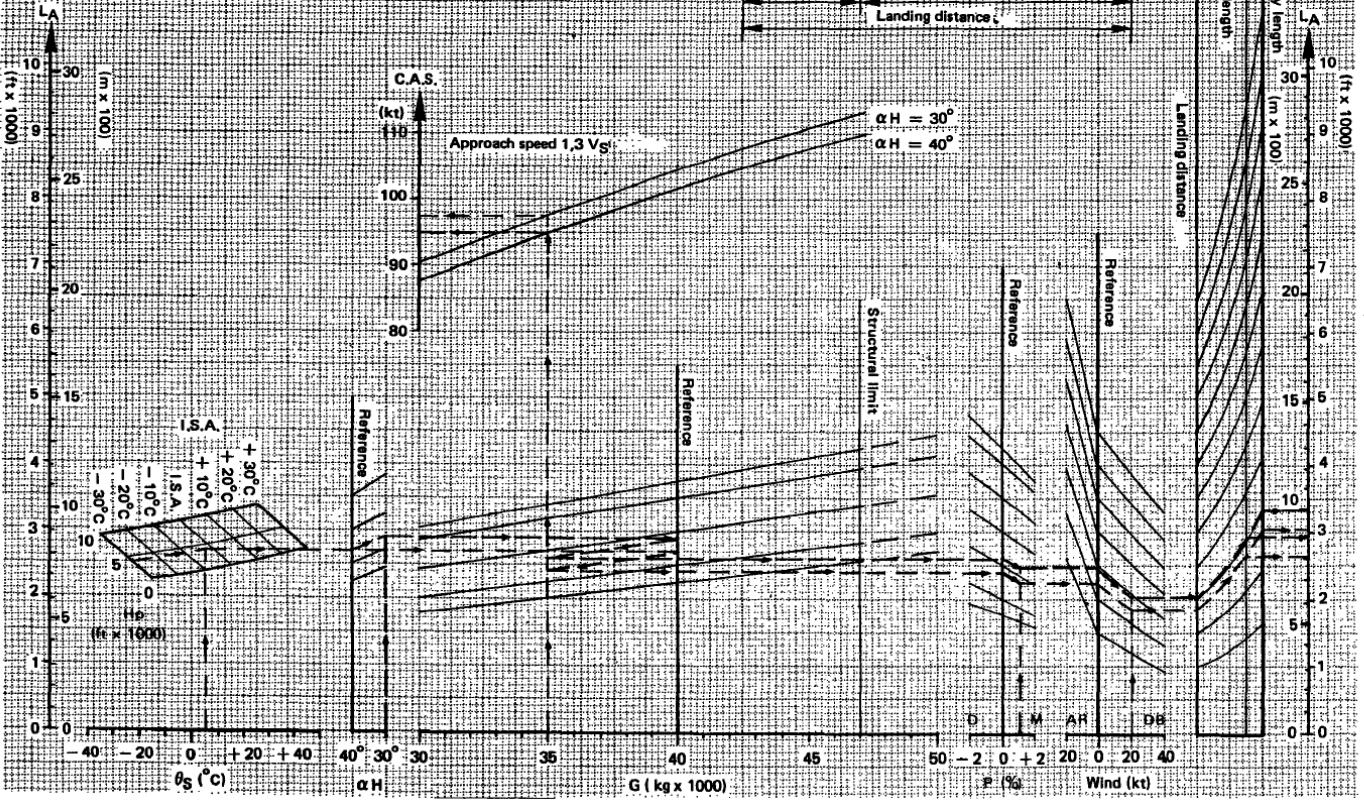
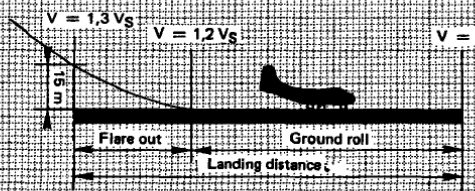

**LANDING DISTANCE ON SHORT AIRFIELDS** With propeller reverse pitch

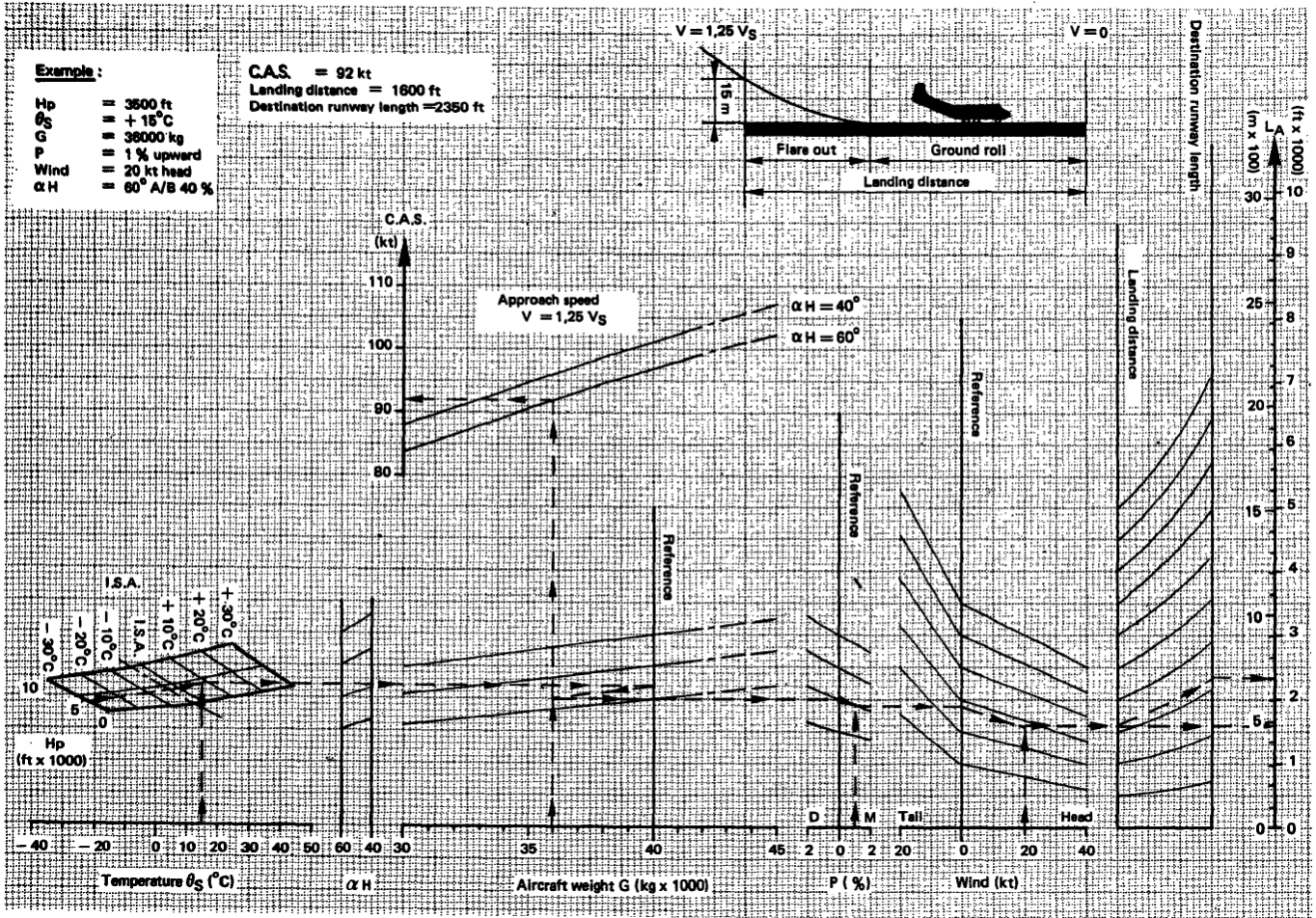

Similarly to the take-off card, a landing card is filled with essential information related to the landing.

INFO	AIRPORT	LANDING Weight	TRANS.
QFU		Trim	AARG: (HARG):
WIND		C : Nor. E/M.	
VISI			
CEIL		SAFE ALT	
T°		DA	G/A Elevation ft
<b>QNH</b>		DH	
QFE			
0°		VLUNF VLUR	0°
20°			V2
30°			FLAPS
40°			
60°			

CFAP - C160R # 9402004

It is completed with the following steps:

1. Airport OACI code and information based on weather: QFU, wind, visibility, ceiling, temperature, QNH.
2. Landing weight and corresponding trim calculated.
3. Security altitude, decision height and corresponding altitude.
4. Landing speeds depending on flaps setting.
5. Missed approach procedure, with transition altitude and details of the go-around procedure.
6. Go-around speed and flaps setting.

INFO	AIRPORT	LANDING Weight	TRANS.
QFU		Trim	
WIND	<b>1</b>	C : Nor. <b>2</b>	AARG: (HARG): <b>5</b>
VISI		E/M.	
CEIL		SAFE ALT	
T°		DA <b>3</b>	G/A Elevation ft
<b>QNH</b>		DH	
QFE			
0°			0°
20°			<b>6</b>
30°	<b>4</b>	VLUNF VLUR	V2
40°			FLAPS
60°			

CFAP - C160R # 9402004

# Controls assignments

In addition to default control assignments, our aircraft is using custom variables and events to manage all its systems.

Custom variables are called L Vars (prefixed with "L:") and custom events are called H Events (prefixed with "H:").

If you have external hardware and you are using specific software like FSUIPC or SPAD, you can assign buttons or switches to those variables and events.

In order to see custom variables related to the aircraft, you need to enable Developer mode (general options) and go to Tools > Behaviors > Local Variables on top menu bar. All custom variables are prefixed with "AZP\_C160" keyword.

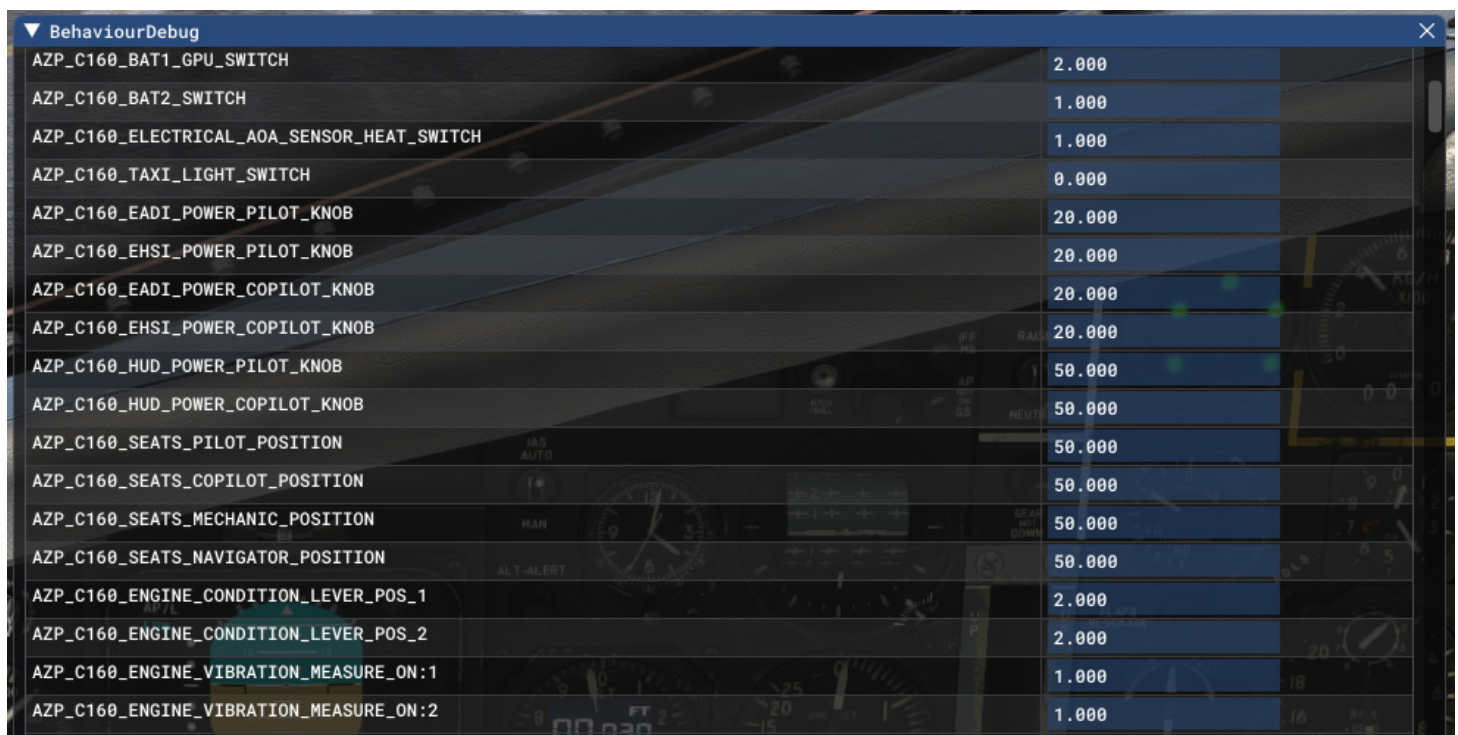

Variable Name	Value
AZP_C160_BAT1_GPU_SWITCH	2.000
AZP_C160_BAT2_SWITCH	1.000
AZP_C160_ELECTRICAL_AOA_SENSOR_HEAT_SWITCH	1.000
AZP_C160_TAXI_LIGHT_SWITCH	0.000
AZP_C160_EADI_POWER_PILOT_KNOB	20.000
AZP_C160_EHSI_POWER_PILOT_KNOB	20.000
AZP_C160_EADI_POWER_COPILOT_KNOB	20.000
AZP_C160_EHSI_POWER_COPILOT_KNOB	20.000
AZP_C160_HUD_POWER_PILOT_KNOB	50.000
AZP_C160_HUD_POWER_COPILOT_KNOB	50.000
AZP_C160_SEATS_PILOT_POSITION	50.000
AZP_C160_SEATS_COPILOT_POSITION	50.000
AZP_C160_SEATS_MECHANIC_POSITION	50.000
AZP_C160_SEATS_NAVIGATOR_POSITION	50.000
AZP_C160_ENGINE_CONDITION_LEVER_POS_1	2.000
AZP_C160_ENGINE_CONDITION_LEVER_POS_2	2.000
AZP_C160_ENGINE_VIBRATION_MEASURE_ON:1	1.000
AZP_C160_ENGINE_VIBRATION_MEASURE_ON:2	1.000

However, changing those L VARS is not always enough and you may need to call the events described in the next section.

## Custom events

Here is non-exhaustive list of main H Events that you can use in order to interact with aircraft systems.

<b>NAME</b>	<b>H EVENT</b>	<b>DESCRIPTION</b>
EFB display	AZP_C160_TOGGLE_EFB_POWER	Display or hide EFB tablet
EFB position	AZP_C160_TOGGLE_EFB_POSITION	Switch between the two EFB positions
Chocks display	AZP_C160_TOGGLE_CHOCKS	Display or hide wheel chocks
Covers display	AZP_C160_TOGGLE_COVERS	Display or hide aircraft covers
Yoke display	AZP_C160_TOGGLE_YOKE_DISPLAY	Display or hide pilot's yoke
General engine starting switch	AZP_C160_ENGINE_GENERAL_STARTER_ZERO AZP_C160_ENGINE_GENERAL_STARTER_VENTILATION AZP_C160_ENGINE_GENERAL_STARTER_ON	Set general engine starting switch position
Engine starter switch	AZP_C160_ENGINE_LEFT_STARTER_ZERO AZP_C160_ENGINE_LEFT_STARTER_ON AZP_C160_ENGINE_LEFT_STARTER_RESTARTING AZP_C160_ENGINE_RIGHT_STARTER_ZERO AZP_C160_ENGINE_RIGHT_STARTER_ON AZP_C160_ENGINE_RIGHT_STARTER_RESTARTING	Set engine starter switch (left and right engine) position
APU air inlet switch	AZP_C160_GTG_AIR_INLET_TOGGLE	Toggle APU air inlet
APU starter switch	AZP_C160_GTG_START_TOGGLE	Toggle APU starter
Electricity source 1 knob	AZP_C160_SOURCE1_GPU AZP_C160_SOURCE1_OFF AZP_C160_SOURCE1_BAT1	Set electricity source 1 knob position
Electricity source 2 knob	AZP_C160_SOURCE2_OFF AZP_C160_SOURCE2_ON	Set electricity source 2 knob position
Generators knobs	AZP_C160_G1_KNOB_OFF AZP_C160_G1_KNOB_ON AZP_C160_G2_KNOB_OFF AZP_C160_G2_KNOB_ON AZP_C160_G3_KNOB_OFF	Set position for each generator

NAME	H EVENT	DESCRIPTION
	AZP_C160_G3_KNOB_ON AZP_C160_G4_KNOB_OFF AZP_C160_G4_KNOB_ON AZP_C160_G5_KNOB_OFF AZP_C160_G5_KNOB_ON	
Fuel shutoff handles	AZP_C160_FUEL_SHUTOFF_LEFT_TOGGLE AZP_C160_FUEL_SHUTOFF_RIGHT_TOGGLE	Toggle emergency fuel shutoff (left and right engine)
Wipers knobs	AZP_C160_WIPER_PILOT_PARK AZP_C160_WIPER_PILOT_OFF AZP_C160_WIPER_PILOT_FAST AZP_C160_WIPER_PILOT_SLOW AZP_C160_WIPER_COPILOT_PARK AZP_C160_WIPER_COPILOT_OFF AZP_C160_WIPER_COPILOT_FAST AZP_C160_WIPER_COPILOT_SLOW	Set wiper knob position for pilot and copilot
IRS power knob	AZP_C160_IRS_1_OFF AZP_C160_IRS_1_NAV AZP_C160_IRS_1_ATT AZP_C160_IRS_2_OFF AZP_C160_IRS_2_NAV AZP_C160_IRS_2_ATT	Set IRS power knob position (IRS1 and IRS2)
IFF power knob	AZP_C160_IFF_POWER_KNOB_OFF AZP_C160_IFF_POWER_KNOB_STBY AZP_C160_IFF_POWER_KNOB_NORM AZP_C160_IFF_POWER_KNOB_EMER	Set IFF (transponder) power knob position
IFF keyboard	AZP_C160_IFF_DIGIT_0 AZP_C160_IFF_DIGIT_1 AZP_C160_IFF_DIGIT_2 AZP_C160_IFF_DIGIT_3 AZP_C160_IFF_DIGIT_4 AZP_C160_IFF_DIGIT_5 AZP_C160_IFF_DIGIT_6 AZP_C160_IFF_DIGIT_7 AZP_C160_IFF_CLR	Events to type a new transponder code

NAME	H EVENT	DESCRIPTION
EADI decision height knob	AZP_C160_DSP_DECISION_HEIGHT_INC_#INDEX#	Change decision height on EADI. #INDEX# should be replaced by 1 or 2 to alter pilot or copilot side
EHSI chronometer functions	AZP_C160_DSP_CHRONO_START_STOP_#INDEX# AZP_C160_DSP_CHRONO_RESET_#INDEX# AZP_C160_DSP_CHRONO_INC_#INDEX# AZP_C160_DSP_CHRONO_DEC_#INDEX#	Use chronometer functions: start/stop, reset, increase/decrease countdown. #INDEX# should be replaced by 1 or 2 to alter pilot or copilot side
EHSI CRS toggle button	AZP_C160_DSP_CRSEL_TOGGLE_#INDEX#	Toggle active CRS (1 or 2). #INDEX# should be replaced by 1 or 2 to alter pilot or copilot side
EHSI CRS setting knob	AZP_C160_DSP_CRSEL_INC_#INDEX# AZP_C160_DSP_CRSEL_DEC_#INDEX#	Increase or decrease CRS. #INDEX# should be replaced by 1 or 2 to alter pilot or copilot side
EHSI needle source toggle	AZP_C160_DSP_SINGLE_NEEDLE_SOURCE_TOGGLE_#INDEX# AZP_C160_DSP_DOUBLE_NEEDLE_SOURCE_TOGGLE_#INDEX#	Toggle active source for single and double needle. #INDEX# should be replaced by 1 or 2 to alter pilot or copilot side
EHSI mode knob	AZP_C160_DSP_EHSI_MODE_MAP_#INDEX# AZP_C160_DSP_EHSI_MODE_ARC_#INDEX# AZP_C160_DSP_EHSI_MODE_HSI_#INDEX#	Set EHSI display mode (map, arc or HSI). #INDEX# should be replaced by 1 or 2 to alter pilot or copilot side
EHSI range knob	AZP_C160_DSP_EHSI_RANGE_INC_#INDEX# AZP_C160_DSP_EHSI_RANGE_DEC_#INDEX#	Increase or decrease EHSI range. #INDEX# should be replaced by 1 or 2 to alter pilot or copilot side
FMS power button	AZP_C160_FMS_ON_OFF_PRESSED_#INDEX#	Toggle FMS power. #INDEX# should be

NAME	H EVENT	DESCRIPTION
		replaced by 1 or 2 to alter pilot or copilot side
FMS brightness setting	AZP_C160_FMS_BRIGHTNESS_INC_PRESSED_#INDEX# AZP_C160_FMS_BRIGHTNESS_DEC_PRESSED_#INDEX#	Increase or decrease FMS brightness. #INDEX# should be replaced by 1 or 2 to alter pilot or copilot side
FMS functions buttons	AZP_C160_FMS_UP_PRESSED_#INDEX# AZP_C160_FMS_DOWN_PRESSED_#INDEX# AZP_C160_FMS_ENT_PRESSED_#INDEX# AZP_C160_FMS_CLR_PRESSED_#INDEX# AZP_C160_FMS_EXP_PRESSED_#INDEX#	Click on FMS function button (UP, DOWN, ENT, CLR, ECP). #INDEX# should be replaced by 1 or 2 to alter pilot or copilot side
FMS key button	AZP_C160_FMS_KEY0_PRESSED_#INDEX# AZP_C160_FMS_KEY1_PRESSED_#INDEX# AZP_C160_FMS_KEY2_PRESSED_#INDEX# AZP_C160_FMS_KEY3_PRESSED_#INDEX# AZP_C160_FMS_KEY4_PRESSED_#INDEX# AZP_C160_FMS_KEY5_PRESSED_#INDEX# AZP_C160_FMS_KEY6_PRESSED_#INDEX# AZP_C160_FMS_KEY7_PRESSED_#INDEX# AZP_C160_FMS_KEY8_PRESSED_#INDEX# AZP_C160_FMS_KEY9_PRESSED_#INDEX#	Click on FMS key. #INDEX# should be replaced by 1 or 2 to alter pilot or copilot side
FMS character choice button	AZP_C160_FMS_LETTER_LEFT_PRESSED_#INDEX# AZP_C160_FMS_LETTER_CENTER_PRESSED_#INDEX# AZP_C160_FMS_LETTER_RIGHT_PRESSED_#INDEX#	Click on button to choose between the three characters of a key. #INDEX# should be replaced by 1 or 2 to alter pilot or copilot side
FMS TLV button	AZP_C160_FMS_TLV1_PRESSED_#INDEX# AZP_C160_FMS_TLV2_PRESSED_#INDEX# AZP_C160_FMS_TLV3_PRESSED_#INDEX# AZP_C160_FMS_TLV4_PRESSED_#INDEX# AZP_C160_FMS_TLV5_PRESSED_#INDEX#	Click on TLV button. #INDEX# should be replaced by 1 or 2 to alter pilot or copilot side
FMS radiocom	AZP_C160_BCR_RADIOCOM_PRESSED_#INDEX#	Access radiocom page. #INDEX# should be

NAME	H EVENT	DESCRIPTION
page		replaced by 1 or 2 to alter pilot or copilot side
FMS radionav page	AZP_C160_BCR_RADIONAV_PRESSED_#INDEX#	Access radionav page. #INDEX# should be replaced by 1 or 2 to alter pilot or copilot side
FMS altitude page	AZP_C160_BCR_ALTITUDE_PRESSED_#INDEX#	Access altitude page. #INDEX# should be replaced by 1 or 2 to alter pilot or copilot side
Flares power knob	AZP_C160_FLARES_POWER_ON AZP_C160_FLARES_POWER_OFF AZP_C160_FLARES_POWER_TEST	Set flares panel power knob position
Flares fire button	AZP_C160_FLARES_FIRE	Trigger flares fire
Flares reload	AZP_C160_FLARES_RELOAD	Reload flares

# MSFS 2024 specific

You will find in the section everything specific to the Transall for MSFS 2024 (native add-on).

## Preflight actions

In Flight Simulator 2024, the flight will start on the apron at the exterior of the aircraft.

Before entering the aircraft, you need to click on ground equipment, to remove it before flight:

- Chocks.
- Engine intake covers.
- Pitot and static covers.



By walking around the aircraft, you can inspect various parts (struts, rudder, elevator, etc) and check their condition before flying. Each part to inspect or remove is indicated by a circled dot.

In order to climb on top of the aircraft for further inspection, you can display a scissor lift from the EFB. Once you climbed in it, you can use the small lever to make the lift rise.



Click on left door to enter the aircraft. You can also use a keyboard shortcut (default Maj + C) to go directly inside the cockpit.



From the EFB (first tab), you can click on QUICK PREFLIGHT to do all the preflight automatically. The engine will not start with intake covers on.

## SimBrief integration

To import a SimBrief flight plan, you need it to be the latest one generated on your account.

You can use the C160 profile to get the correct flight performance.

## Flight Info

Airline <small>ICAO</small>	Flight Number	Depart <small>📍</small> <small>↔</small>	Arrive <small>📍</small>	Alternate <small>📍</small>	Departure Time <small>EOBT</small> <small>🔄</small>
ZZZ	0000	LFKB <small>🔍</small>	LFL <small>🔍</small>	NONE <small>▼</small>	27 Aug 2025 - 08:55 <small>▼</small>

## Aircraft Info

[Open Airframe Editor](#)

Aircraft Type	Variant or Airframe	Sort by Registration <small>▼</small> <small>📄</small>		
C160 - Transall C-160 <small>▼</small>	Default <small>▼</small>			
Climb Profile	Cruise Profile	Descent Profile	ATC Callsign	<a href="#">More Options</a> <small>▼</small>
140KTS <small>▼</small>	13500RPM <small>▼</small>	180KTS <small>▼</small>	N160SB	

Once flight plan is generated, you need to go to DATA (DTA) page on the FMS. This page is accessed from [INIT1](#) page using TLV keys.

On this page, you have to enter your Navigraph username linked to your account (type and click on ENT button).



Then, clicking ENT with cursor on "FETCH SIMBRIEF" will fetch your latest flight plan from SimBrief.

A message will be displayed if flight plan is invalid.



Once flight plan is retrieved, origin and destination are displayed.



After clicking ENT on "VALIDATE" line, flight plan is automatically imported into the FMS.



**⚠ WARNING**

Departure and arrival procedures (SID/STAR) are not imported and need to be selected manually.

## Copilot display

In MSFS 2024, the copilot can only be managed from the simulator tablet.

In order to display (or not) the copilot, you need to assign a weight to its seat, and click on "LOAD AIRCRAFT".

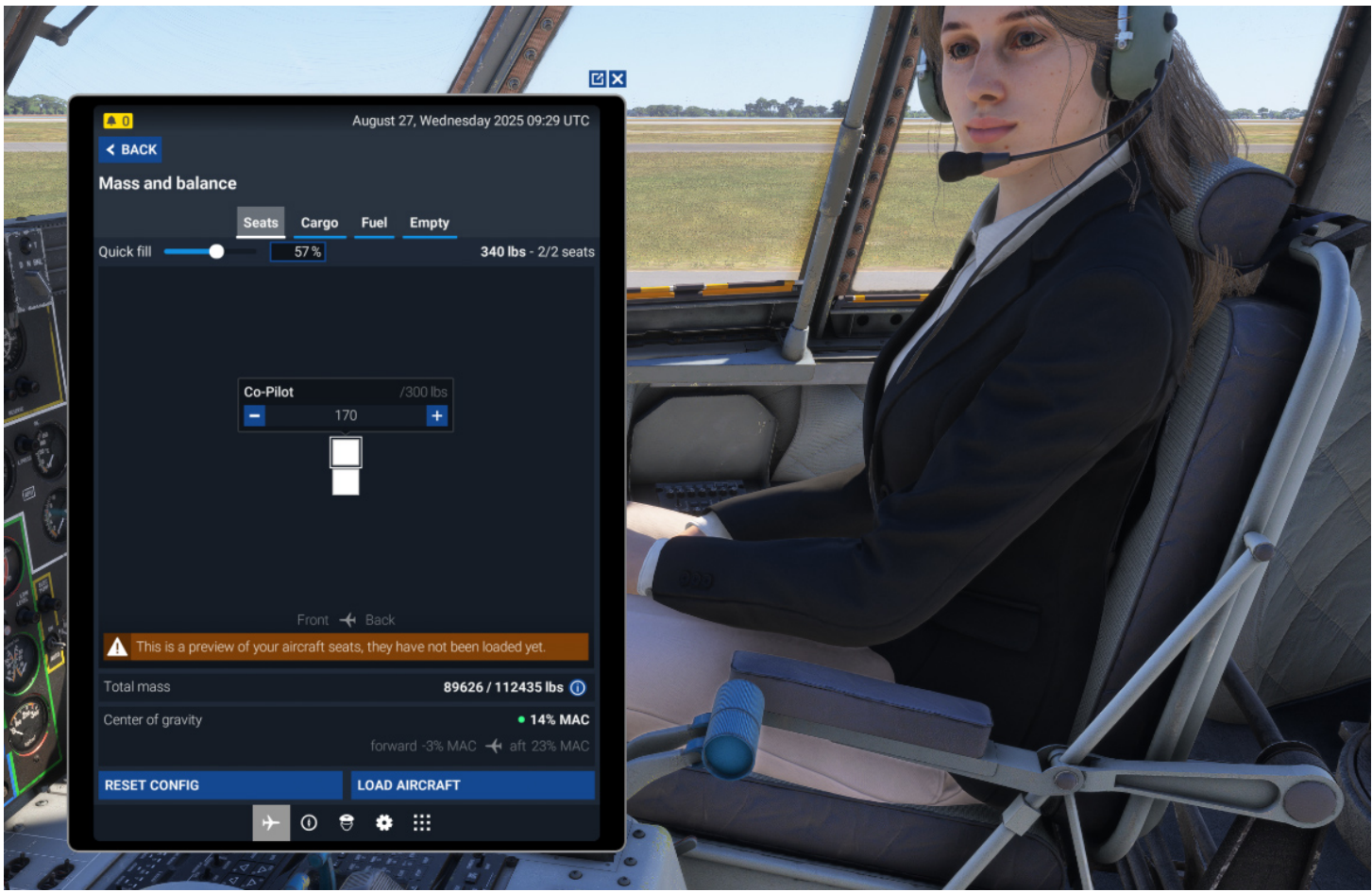

August 27, Wednesday 2025 09:29 UTC

< BACK

### Mass and balance

Seats Cargo Fuel Empty

Quick fill  57% 340 lbs - 2/2 seats

Co-Pilot /300 lbs  
- 170 +



Front ← Back

**⚠** This is a preview of your aircraft seats, they have not been loaded yet.

Total mass 89626 / 112435 lbs ⓘ

Center of gravity 14% MAC  
forward -3% MAC ← aft 23% MAC

RESET CONFIG

LOAD AIRCRAFT

